

DESCRIPTION: INTERNAL DIMENSIONS - DIE CAST

DIMENSIONS (IN.)

	9	15	25	37
A	0.917	1.077	1.600	2.263
B*	0.694	0.690	0.720	0.733
C				1.512
D				0.365
PCB	0.443	0.443	0.443	0.443

SEE NOTE 1. →

SEE NOTE 2. →

NOTE:

- "B" DIMENSION MEASURED FROM BACK SIDE OF CONNECTOR FLANGE
- MIN. SAFE SPACING BETWEEN BACK SHELLS FOR PCB AND MOUNTED COMPONENTS
- THESE DIMENSIONS ARE GOOD FOR THE NICKEL PLATED DIE CAST BACK SHELLS

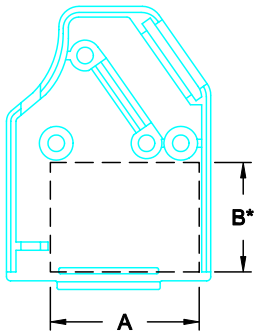

9-PIN

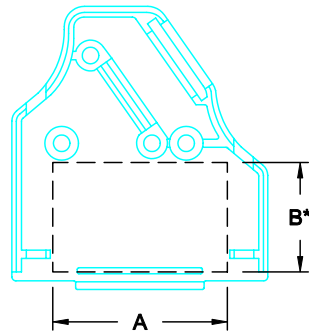

15-PIN

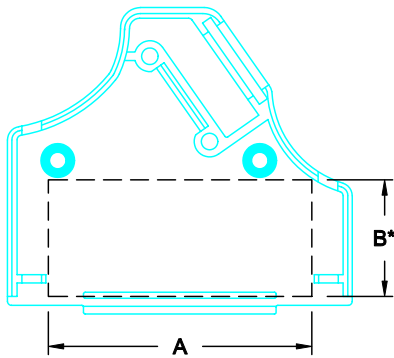

25-PIN

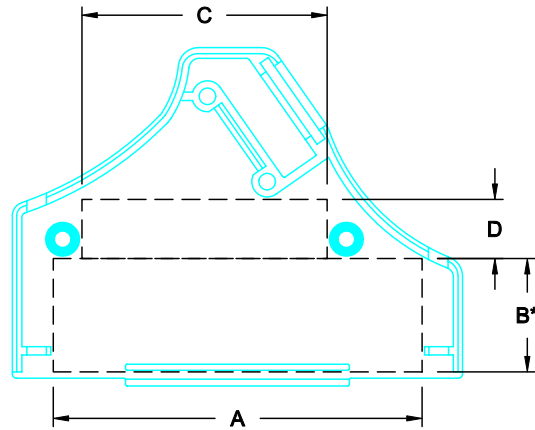

37-PIN

DIE CAST

DO NOT SCALE FROM DRAWING

RoHS COMPLIANT



THESE DRAWINGS AND SPECIFICATIONS ARE THE PROPERTY OF NorComp AND SHALL NOT BE REPRODUCED, COPIED OR USED AS THE BASIS FOR THE MANUFACTURE OF SALE OF APPARATUS WITHOUT WRITTEN PERMISSION.

DRAWN:
C. SMITH

DATE:
03-23-07

CHECKED:

DATE:

SCALE:
N.T.S.

SHEET 1 OF 1

REV 0

NorComp

DWG NO. ID - 953 SERIES