

DESCRIPTION: BACKSHELL ASSEMBLY INSTRUCTIONS - DIE CAST

ASSEMBLY INSTRUCTIONS:

1. PREPARE CABLE ENDS, CONNECT TO CONNECTOR
2. CLAMP STRAIN RELIEF ONTO CABLE MAKING SURE CABLE JACKET IS BELOW STRAIN RELIEF
3. IF CABLE IS SHIELDED, FOLD SHIELD AND/OR GROUND WIRE BACK UNDER STRAIN RELIEF. CUT OFF ANY EXCESS WIRE SO IT DOES NOT STICK OUT OF THE CONNECTOR
4. PLACE STRAIN RELIEF INSIDE STRAIN RELIEF AREA OF ONE HOOD
5. PLACE THE OTHER HALVE OF THE HOOD ON TOP OF THE FIRST HALF, MAKING SURE NO WIRES ARE PINCHED
6. HOLDING THE HOODS TOGETHER, INSERT THE MOUNTING SCREWS THROUGH THE HOODS IN OPPOSITE DIRECTIONS. TIGHTEN THE TWO HALVES TOGETHER

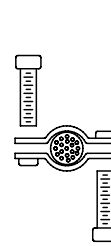
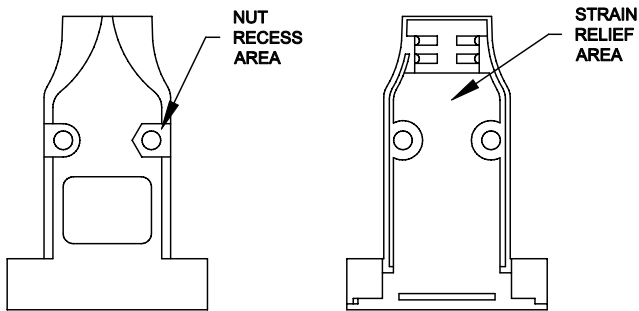

STRAIN RELIEF MOUNTING DETAIL

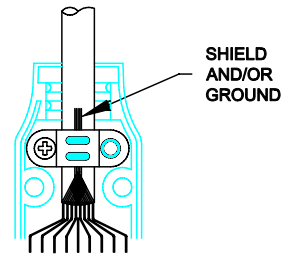

ITEM No. 2, 3 & 4



STRAIN RELIEF CLAMP

RoHS COMPLIANT

DIE CAST

	<small>THESE DRAWINGS AND SPECIFICATIONS ARE THE PROPERTY OF NorComp AND SHALL NOT BE REPRODUCED, COPIED OR USED AS THE BASIS FOR THE MANUFACTURE OF SALE OF APPARATUS WITHOUT WRITTEN PERMISSION.</small>		<small>DRAWN:</small> C. SMITH	<small>DATE:</small> 04-18-06
			<small>CHECKED:</small> X	<small>DATE:</small> X
<h1>NorComp</h1>		<small>SCALE:</small> N.T.S.	<small>SHEET</small> 1 <small>OF</small> 1	<small>REV</small> 0
		<small>DWG NO.</small> BACKSHELL - 994 SERIES		