

DESCRIPTION: BACKSHELL ASSEMBLY INSTRUCTIONS - PLASTIC

**ASSEMBLY INSTRUCTIONS:**

1. PREPARE CABLE AS REQUIRED TO ASSEMBLE TO THE CONNECTOR
2. CHOOSE THE STRAIN RELIEF HALVES THAT MOST CLOSELY MATCH THE CABLE O/D AND PLACE ONE INTO EACH RECESS. THEY DO NOT NEED TO BE MATCHING HALVES
3. PLACE THE CABLE INTO THE STRAIN RELIEF IN ONE HALF OF THE PLASTIC HOOD. ENSURE THE CABLE IS PRESSED INTO THE STRAIN RELIEF PIECE
4. SNAP THE JACKSCREWS INTO POSITION
5. PLACE THE OTHER HALF OF THE PLASTIC HOOD INTO PLACE AND TIGHTEN TOGETHER WITH THE ASSEMBLY SCREWS AND NUTS

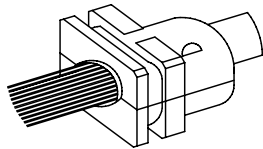
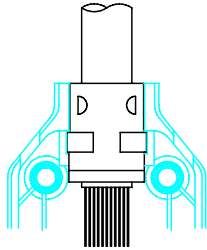
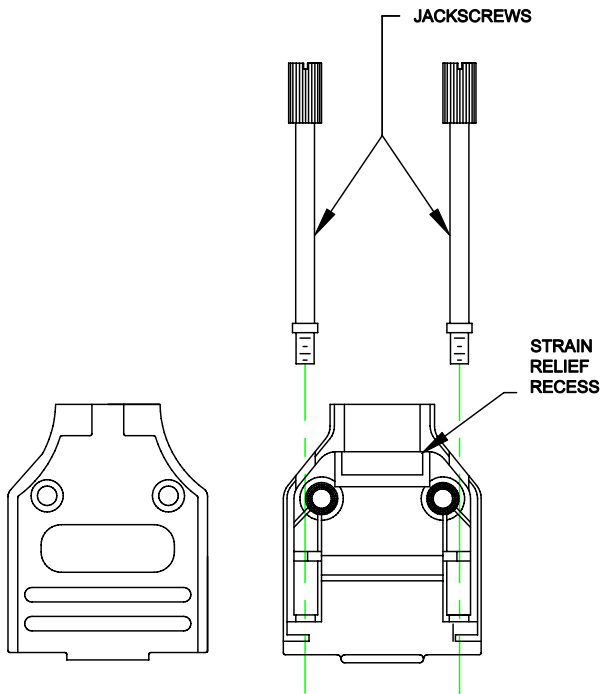

CABLE WITHOUT SHIELD OR GROUND

**RoHS COMPLIANT**

**PLASTIC**

	THESE DRAWINGS AND SPECIFICATIONS ARE THE PROPERTY OF NorComp AND SHALL NOT BE REPRODUCED, COPIED OR USED AS THE BASIS FOR THE MANUFACTURE OF SALE OF APPARATUS WITHOUT WRITTEN PERMISSION.		DRAWN: <b>C. SMITH</b>	DATE: <b>03-20-06</b>
			CHECKED: <b>X</b>	DATE: <b>X</b>
<h1>NorComp</h1>		SCALE: <b>N.T.S.</b>	SHEET <b>1</b> OF <b>2</b>	REV <b>0</b>
		DWG NO. <b>BACKSHELL - 970 SERIES</b>		

DESCRIPTION: BACKSHELL ASSEMBLY INSTRUCTIONS - DIE CAST & METALIZED PLASTIC

**ASSEMBLY INSTRUCTIONS:**

1. PREPARE CABLE AS REQUIRED TO ASSEMBLE TO THE CONNECTOR
2. CHOOSE THE STRAIN RELIEF HALVES THAT MOST CLOSELY MATCH THE CABLE O/D AND PLACE ONE INTO EACH RECESS. THEY DO NOT NEED TO BE MATCHING HALVES
3. USE THE METAL SHIELD SUPPORT TO ISOLATE THE BRAID/DRAIN WIRE TO THE DIE CAST SHELL
4. PLACE THE CABLE ASSEMBLY/SHIELD SUPPORT INTO THE APPROPRIATE RECESS IN ONE HALF OF THE DIE CAST HOOD. ENSURE THE CABLE IS PRESSED INTO THE STRAIN RELIEF PIECE
5. SNAP THE JACKSCREWS INTO POSITION
6. PLACE THE OTHER HALF OF THE DIE CAST HOOD INTO PLACE AND TIGHTEN TOGETHER WITH THE ASSEMBLY SCREWS

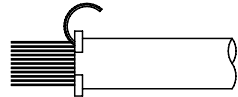
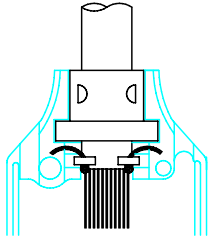
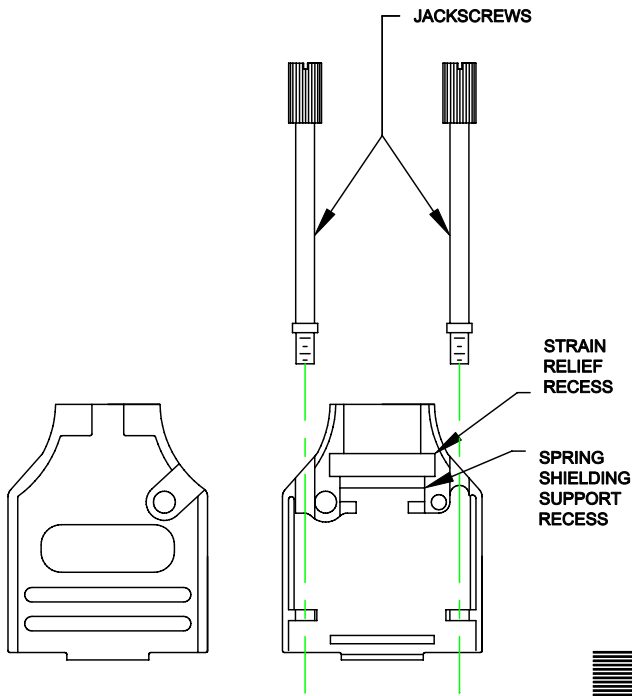

LIGHT BRAIDED CABLE OR CABLE WITH FOIL AND DRAIN WIRE

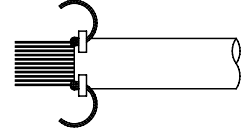

HEAVY BRAIDED CABLE

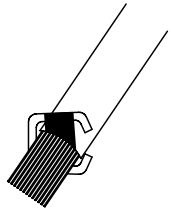

GENERAL VIEW

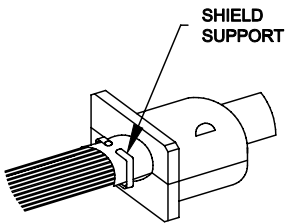

SHIELD NOT SHOWN FOR CLARITY

**DIE CAST & METALIZED PLASTIC**

**RoHS COMPLIANT**

	THESE DRAWINGS AND SPECIFICATIONS ARE THE PROPERTY OF NorComp AND SHALL NOT BE REPRODUCED, COPIED OR USED AS THE BASIS FOR THE MANUFACTURE OF SALE OF APPARATUS WITHOUT WRITTEN PERMISSION.	DRAWN: <b>C. SMITH</b>	DATE: <b>03-20-06</b>
		CHECKED: <b>X</b>	DATE: <b>X</b>
NorComp		SCALE: N.T.S.	SHEET 2 OF 2
		DWG NO.	REV 0
BACKSHELL - 970 SERIES			