

DESCRIPTION: BACKSHELL ASSEMBLY INSTRUCTIONS - PLASTIC

ASSEMBLY INSTRUCTIONS:

1. PREPARE CABLE ENDS, CONNECT TO CONNECTOR
2. SNAP JACKSCREWS INTO PLACE
3. SNAP STRAIN RELIEF INTO STRAIN RELIEF RECESS AREA ON RIGHT SIDE OF HOOD
4. PLACE CABLE OVER STRAIN RELIEF MAKING SURE CABLE JACKET IS BELOW STRAIN RELIEF
5. PLACE CABLE CLAMP OVER CABLE. USING SCREWS PROVIDED TIGHTEN CABLE CLAMP INTO PLACE. CABLE CLAMP MAY BE INSERTED UP SIDE DOWN FOR SMALLER CABLES
6. SNAP THE TWO HALVES OF THE HOOD TOGETHER MAKING SURE NO WIRES ARE PINCHED AND THE TWO PLASTIC SNAP PINS ARE SEATED

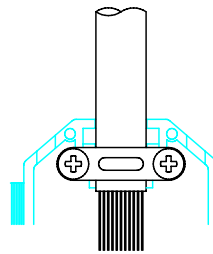
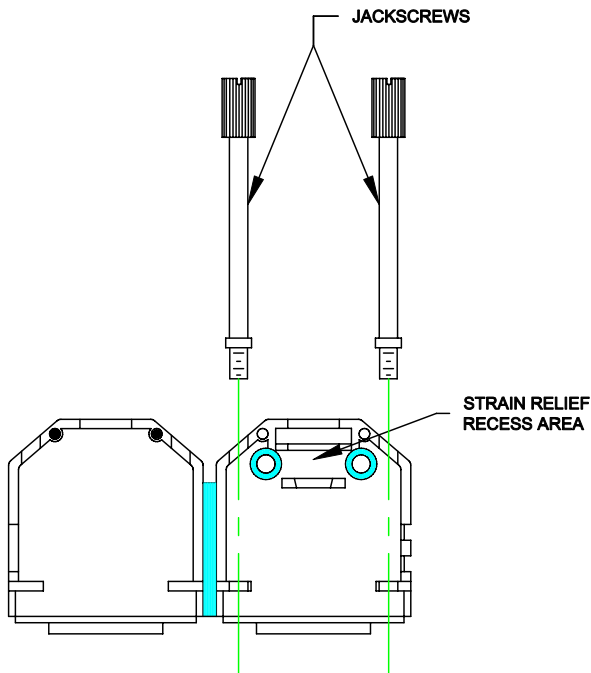

ITEM No. 3, 4 & 5

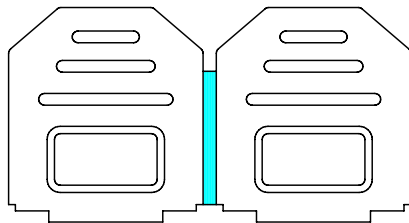
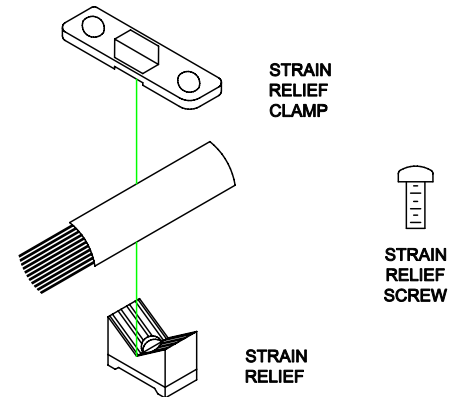

RoHS COMPLIANT

PLASTIC

	THESE DRAWINGS AND SPECIFICATIONS ARE THE PROPERTY OF NorComp AND SHALL NOT BE REPRODUCED, COPIED OR USED AS THE BASIS FOR THE MANUFACTURE OF SALE OF APPARATUS WITHOUT WRITTEN PERMISSION.		DRAWN: C. SMITH	DATE: 03-23-06
			CHECKED: X	DATE: X
NorComp	SCALE: N.T.S.	SHEET 1 OF 1	REV 0	
	DWG NO. BACKSHELL - 972 SERIES			