

DESCRIPTION: BACKSHELL ASSEMBLY INSTRUCTIONS - PLASTIC

ASSEMBLY INSTRUCTIONS:

1. PREPARE CABLE ENDS, CONNECT TO CONNECTOR
2. SNAP CABLE CLAMP INTO ONE HALF OF THE HOOD
3. CLAMP STRAIN RELIEF ONTO CABLE MAKING SURE CABLE JACKET IS BELOW STRAIN RELIEF
4. INSERT THE STRAIN RELIEF INTO THE STRAIN RELIEF RECESS AREA OF THE CABLE CLAMP
5. INSERT THE JACKSCREWS INTO THE SADDLE WASHERS. PLACE THE JACKSCREWS INTO THE HOOD WITH THE CABLE
6. PLACE THE OTHER HALVE OF THE HOOD ON TOP OF THE FIRST HALF, MAKING SURE NO WIRES ARE PINCHED AND SNAP THE TWO HALVES TOGETHER MAKING SURE THEY ARE FULLY SEATED

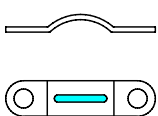
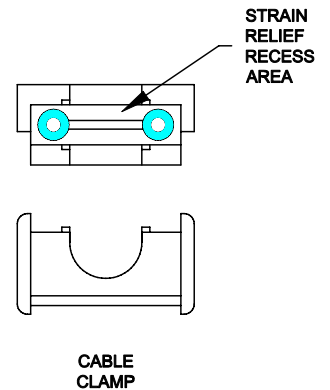
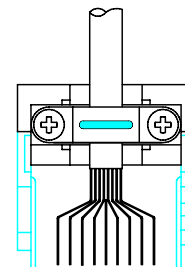
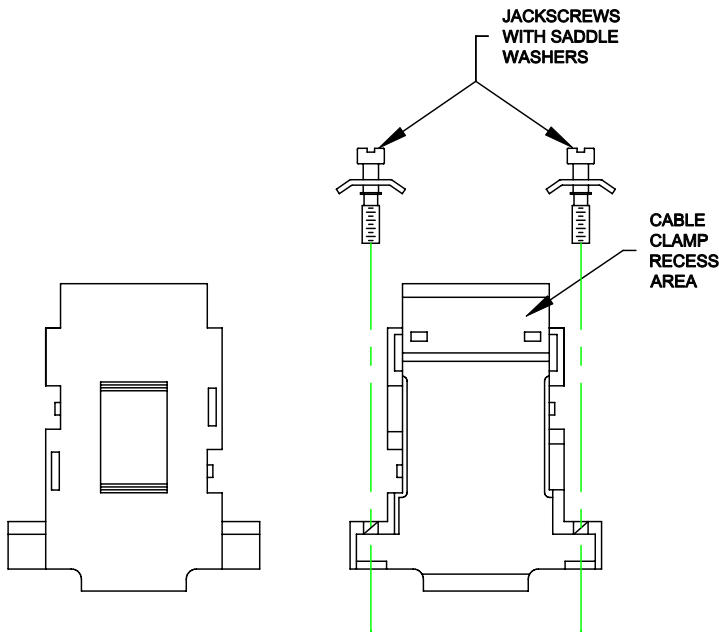

STRAIN RELIEF CLAMP



STRAIN RELIEF SCREW

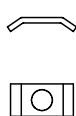

SADDLE WASHER

RoHS COMPLIANT

PLASTIC

| | | | | |
|---|---|---------------------------------------|----------------------------|--------------------------|
|  | THESE DRAWINGS AND SPECIFICATIONS ARE THE PROPERTY OF NorComp AND SHALL NOT BE REPRODUCED, COPIED OR USED AS THE BASIS FOR THE MANUFACTURE OF SALE OF APPARATUS WITHOUT WRITTEN PERMISSION. | | DRAWN: C. SMITH | DATE: 04-12-06 |
| | | | CHECKED: X | DATE: X |
| <h1>NorComp</h1> | | SCALE: N.T.S. | SHEET 1 OF 3 | REV 0 |
| | | DWG NO. BACKSHELL - 983 SERIES | | |

DESCRIPTION: BACKSHELL ASSEMBLY INSTRUCTIONS - METALIZED PLASTIC

ASSEMBLY INSTRUCTIONS:

1. PREPARE CABLE ENDS, CONNECT TO CONNECTOR
2. SNAP CABLE CLAMP INTO ONE HALF OF THE HOOD
3. CLAMP STRAIN RELIEF ONTO CABLE MAKING SURE CABLE JACKET IS BELOW STRAIN RELIEF
4. IF CABLE IS SHIELDED, FOLD SHIELD AND/OR GROUND WIRE BACK UNDER STRAIN RELIEF. CUT OFF ANY EXCESS WIRE SO IT DOES NOT STICK OUT OF THE HOOD
5. INSERT THE STRAIN RELIEF INTO THE STRAIN RELIEF RECESS AREA OF THE CABLE CLAMP
6. INSERT THE JACKSCREWS INTO THE SADDLE WASHERS. PLACE THE JACKSCREWS INTO THE HOOD WITH THE CABLE
7. PLACE THE OTHER HALVE OF THE HOOD ON TOP OF THE FIRST HALF, MAKING SURE NO WIRES ARE PINCHED AND SNAP THE TWO HALVES TOGETHER MAKING SURE THEY ARE FULLY SEATED

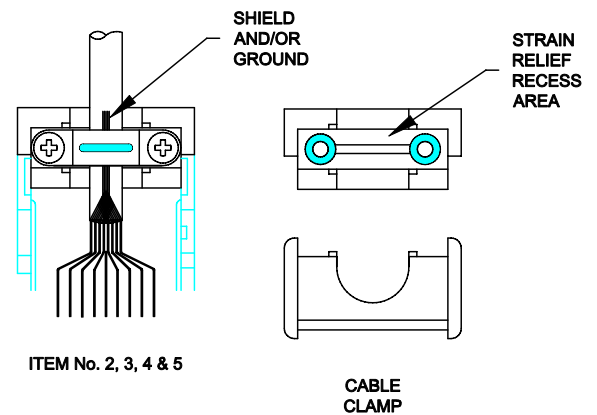
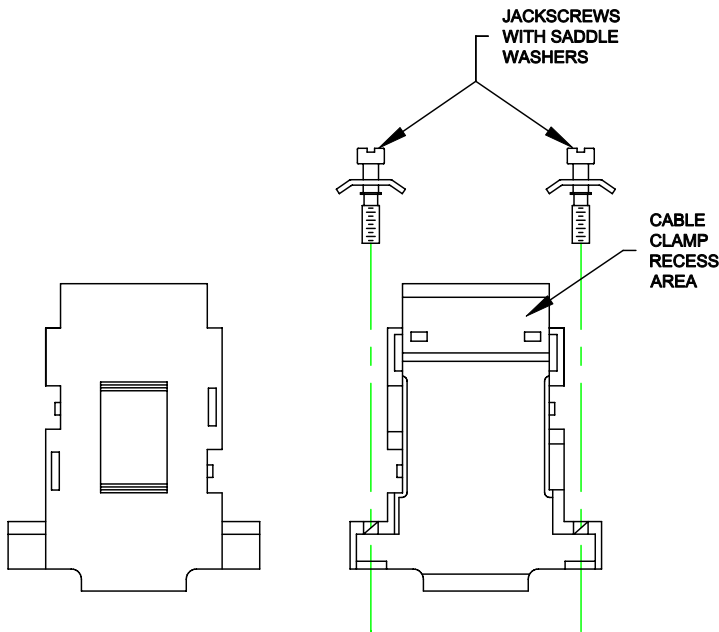

ITEM No. 2, 3, 4 & 5

CABLE CLAMP

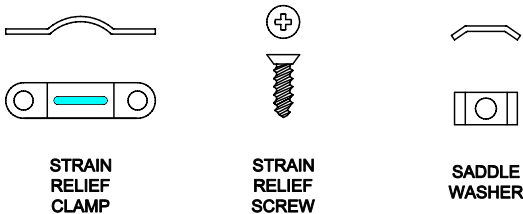

RoHS COMPLIANT

METALIZED PLASTIC

| | | | | |
|---|---|---------------------------------------|----------------------------|--------------------------|
|  | THESE DRAWINGS AND SPECIFICATIONS ARE THE PROPERTY OF NorComp AND SHALL NOT BE REPRODUCED, COPIED OR USED AS THE BASIS FOR THE MANUFACTURE OF SALE OF APPARATUS WITHOUT WRITTEN PERMISSION. | | DRAWN: C. SMITH | DATE: 04-12-06 |
| | | | CHECKED: X | DATE: X |
| <h1>NorComp</h1> | | SCALE: N.T.S. | SHEET 2 OF 3 | REV 0 |
| | | DWG NO. BACKSHELL - 983 SERIES | | |

DESCRIPTION: BACKSHELL ASSEMBLY INSTRUCTIONS - GENDER CHANGER

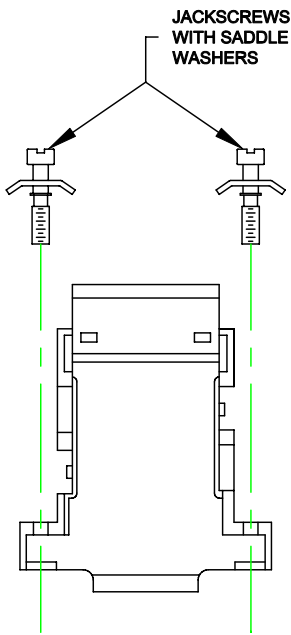

OPEN HOOD
WITHOUT
CONNECTORS

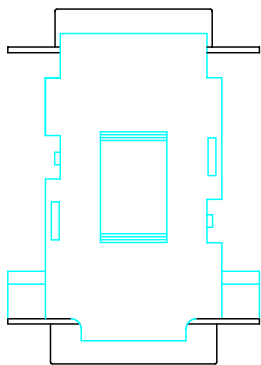

FRONT VIEW
WITH
CONNECTORS

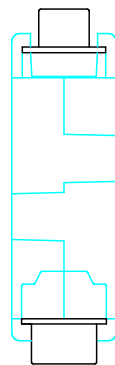

SIDE VIEW
WITH
CONNECTORS



SADDLE
WASHER

ASSEMBLY INSTRUCTIONS:

1. PREPARE THE CONNECTORS, PLACE INTO ONE HALF OF THE HOOD
2. DISCARD ALL HARDWARE EXCEPT THE JACKSCREWS AND THE SADDLE WASHERS
3. INSERT THE JACKSCREWS INTO THE SADDLE WASHERS. PLACE THE JACKSCREWS INTO THE HOOD WITH THE CONNECTORS
4. PLACE THE OTHER HALVE OF THE HOOD ON TOP OF THE FIRST HALF, MAKING SURE NO WIRES ARE PINCHED AND SNAP THE TWO HALVES TOGETHER MAKING SURE THEY ARE FULLY SEATED
5. MALE AND FEMALE CONNECTORS CAN BE INSERTED INTO EITHER END OF THE HOOD

**GENDER CHANGER
PLASTIC
&
METALIZED PLASTIC**

RoHS COMPLIANT

| | | | | |
|---|---|---------------------------------------|----------------------------------|--------------------------|
|  | THESE DRAWINGS AND SPECIFICATIONS ARE THE PROPERTY OF NorComp AND SHALL NOT BE REPRODUCED, COPIED OR USED AS THE BASIS FOR THE MANUFACTURE OF SALE OF APPARATUS WITHOUT WRITTEN PERMISSION. | | DRAWN: C. SMITH | DATE: 04-13-06 |
| | | | CHECKED: X | DATE: X |
| NorComp | | SCALE: N.T.S. | SHEET 3 OF 3 | REV 0 |
| | | DWG NO. BACKSHELL - 983 SERIES | | |