

4

3

2

1

THIS DRAWING IS UNPUBLISHED. RELEASED FOR PUBLICATION
 © COPYRIGHT - BY TYCO ELECTRONICS CORPORATION. ALL RIGHTS RESERVED.

LOC	DIST	REVISIONS			
P	LTR	DESCRIPTION	DATE	DWN	APVD
GP	00				
	J	REVISED PER ECO-07-006056	15/MAR/07	ZMR	WLM

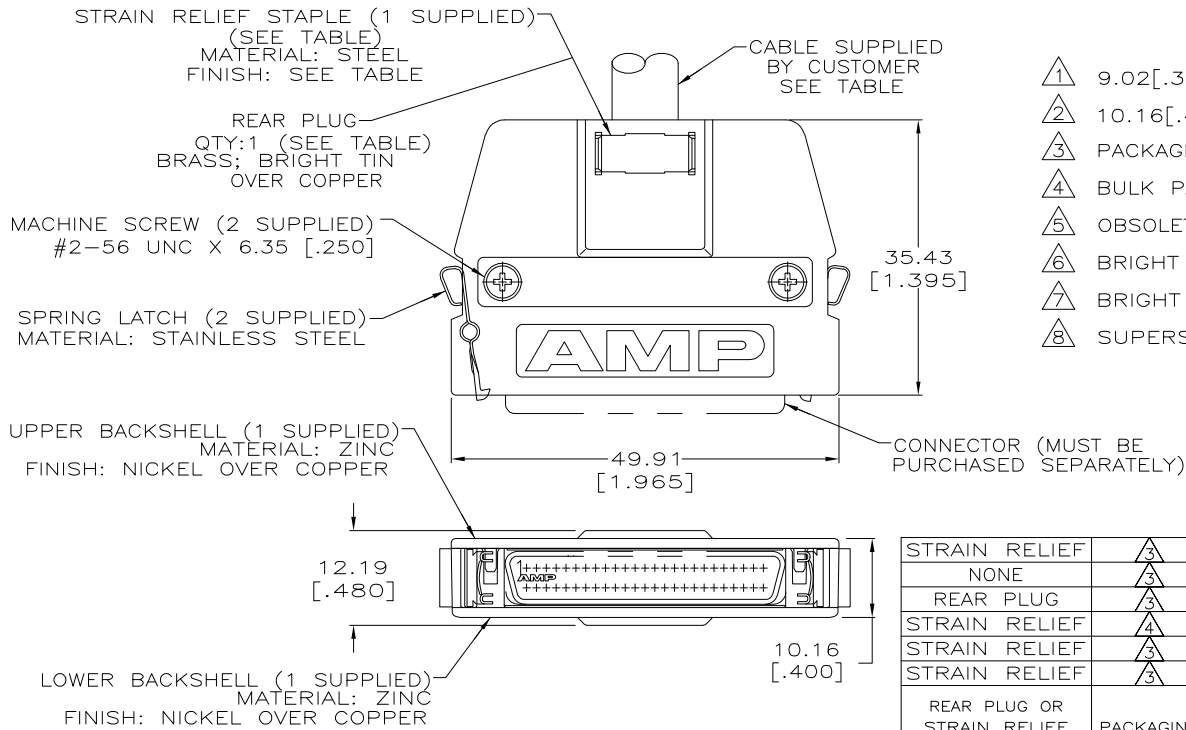

- ① 9.02[.355] MAX CABLE DIAMETER.
- ② 10.16[.400] MAX CABLE DIAMETER.
- ③ PACKAGED ONE KIT PER BAG.
- ④ BULK PACKAGED.
- ⑤ OBSOLETE PART NUMBER.
- ⑥ BRIGHT TIN-LEAD OVER NICKEL.
- ⑦ BRIGHT TIN OVER NICKEL.
- ⑧ SUPERSEDED BY 5749193-2

STRAIN RELIEF	③	①	②	⑧	749193-6/⑤
NONE	③	-	①	⑤	749193-5/⑤
REAR PLUG	⑤	-	①	⑤	749193-4/⑤
STRAIN RELIEF	④	⑥	②	⑤	749193-3/⑤
STRAIN RELIEF	⑤	⑥	②	⑤	749193-2
STRAIN RELIEF	③	⑥	①	⑤	749193-1
REAR PLUG OR STRAIN RELIEF STAPLE	PACKAGING	STAPLE FINISH	CABLE DIA	PART NUMBER	

THIS DRAWING IS A CONTROLLED DOCUMENT.

DIMENSIONS: mm [INCHES]	TOLERANCES UNLESS OTHERWISE SPECIFIED:	DWN M. A. McCAFFREY 12-20-88	Tyco Electronics Corporation Harrisburg, PA 17105-3608	
	0 PLC ± -	CHK M. E. SHIRK 12-20-88	NAME C. E. REYNOLDS	
	1 PLC ± -	APVD C. E. REYNOLDS 12-20-88	PRODUCT SPEC KIT, UNASSEMBLED, 50 POSITION, STRAIGHT EXIT, UNKEYED, AMPLIMITE .050 Series	
	2 PLC ± -		SIZE A3	CAGE CODE 00779
	3 PLC ± 0.38 [015]		DRAWING NO C-749193	RESTRICTED TO -
	4 PLC ± -		WEIGHT -	SCALE 2:1
	ANGLES ± -		CUSTOMER DRAWING	SHEET 1 OF 1
MATERIAL SEE CALLOUTS	FINISH SEE CALLOUTS			REV J

AMP 1470-19 REV 31MAR2000