

DESCRIPTION: COAXIAL / SIGNAL - VERTICAL BOARD - FEMALE

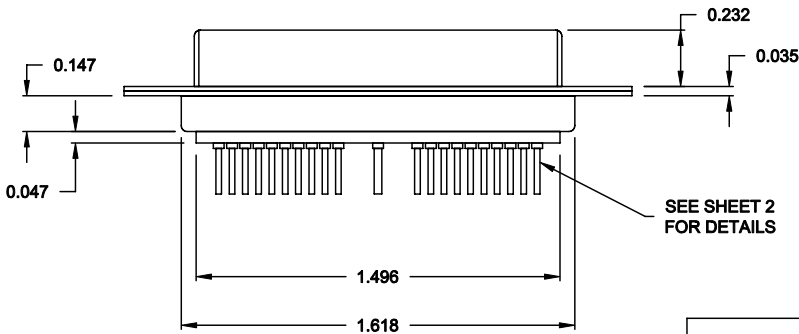
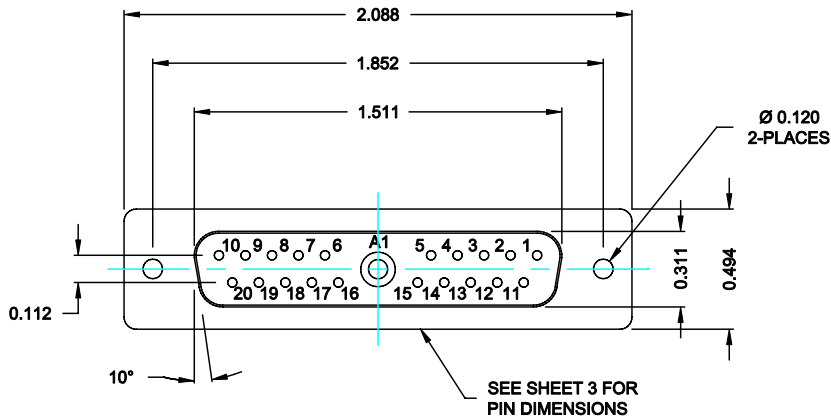

SPECIFICATIONS:

ELECTRICAL:
 INSULATOR RESISTANCE: 5,000 MegOHMS Min.
 DIELECTRIC WITHSTANDING: 1,000VAC r.m.s.
 OPERATING TEMPERATURE: -55° C ~ +125° C
 CONTACT RESISTANCE: 30 Milliohms Max.
 COAXIAL PINS: 75 OHM
 SIGNAL PINS: 3 AMPS

MECHANICAL:
 CONTACT INSERTION FORCE: 4.5 Kg Max.
 CONTACT SEPARATOR FORCE: 0.3Kg Min.

MATERIALS:
 CONTACTS: BRASS
 INSULATOR: PBT UL94V-0 RATED,
 230°C PROCESS TEMP.
 STEEL
 SHELL: STEEL
 FINISH: NICKEL
 SHELL: NICKEL

68321W1203L001

00 = 75 OHM COAXIAL

RoHS COMPLIANT

	THESE DRAWINGS AND SPECIFICATIONS ARE THE PROPERTY OF NorComp AND SHALL NOT BE REPRODUCED, COPIED OR USED AS THE BASIS FOR THE MANUFACTURE OF SALE OF APPARATUS WITHOUT WRITTEN PERMISSION.		DRAWN: C. SMITH	DATE: 10-02-06
			CHECKED: X	DATE: X
NorComp		SCALE: X	SHEET 1 OF 2	REV 0
		DWG NO. 68321W1203L001		

DESCRIPTION: 683 SERIES CONTACTS

NOTE:
SIGNAL AND COAXIAL CONTACTS
COME PRE-LOADED INTO INSULATORS

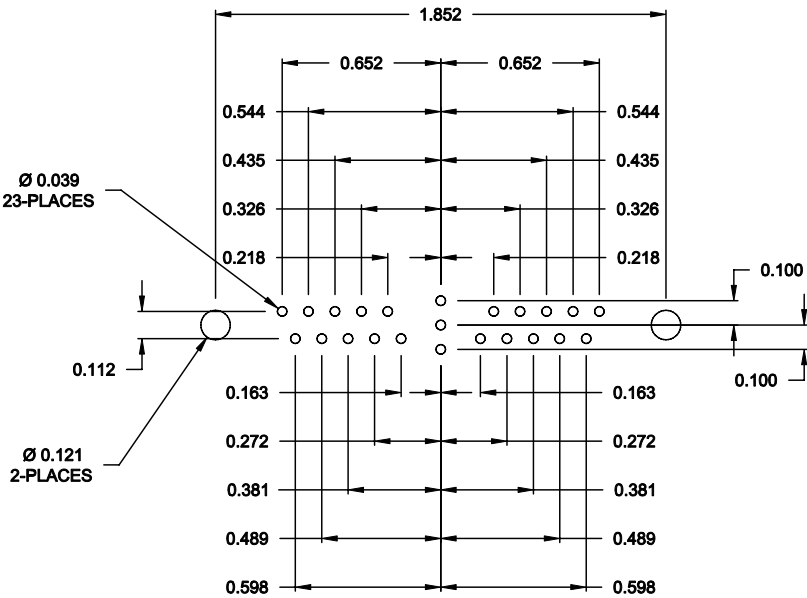

RECOMMENDED PCB LAYOUT

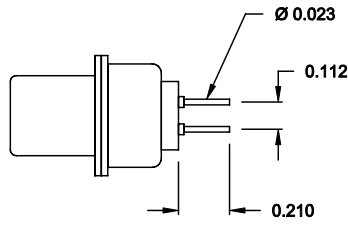

SIGNAL CONTACTS

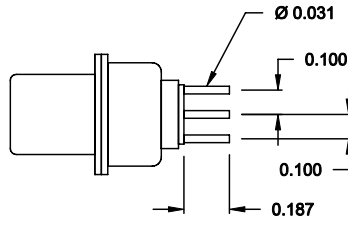

75 OHM COAXIAL CONTACT

RoHS COMPLIANT

	<small>THESE DRAWINGS AND SPECIFICATIONS ARE THE PROPERTY OF NorComp AND SHALL NOT BE REPRODUCED, COPIED OR USED AS THE BASIS FOR THE MANUFACTURE OF SALE OF APPARATUS WITHOUT WRITTEN PERMISSION.</small>		DRAWN: C. SMITH	DATE: 10-02-06
			CHECKED: X	DATE: X
<h1>NorComp</h1>	SCALE: N.T.S.	SHEET 2	OF 2	REV 0
	DWG NO. 68321W1203L001			