

DESCRIPTION: HIGH DENSITY RIGHT ANGLE WITH FERRITE

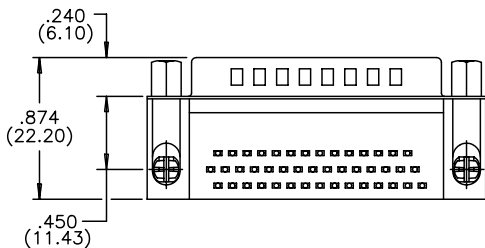
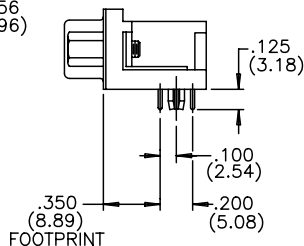
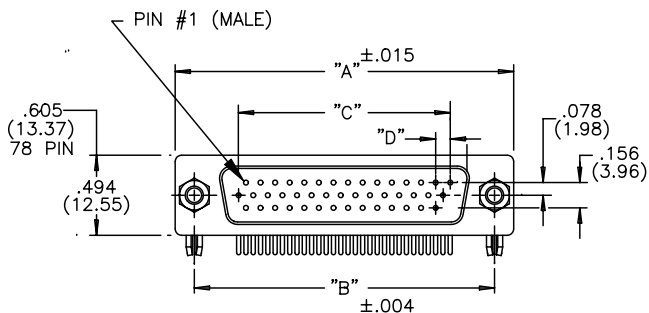

MATERIALS:

INSULATOR: PBT, UL94V-0, 230°C PROCESS TEMP
CHEMICAL RESISTANCE, COLOR BLACK

SHELL: STEEL, NICKEL PLATED

CONTACT: MALE:BRASS; FEMALE:PHOSPHOR BRONZE
GOLD FLASH IN MATING AREA
TIN PLATING ON TAIL ENDS

RoHS COMPLIANT

ELECTRICAL:

CURRENT RATING: 2 AMPERES

DIELECTRIC WITHSTANDING VOLTAGE: 1000VAC rms AT SEA LEVEL

INSULATION RESISTANCE: 5000 MEGOHMS MIN.

CONTACT RESISTANCE: 10 MILLIOHMS MAX.

WORKING TEMPERATURE: -55° TO +125° C

FERRITE SPECS: ATTENUATION - 25 OHMS MIN @ 30Mhz,
35 OHMS MIN @ 50 Mhz, 50 OHMS @ 100 Mhz.

194-XXX-X13LXX1

SERIES _____

NUMBER OF CONTACTS _____

GENDER _____

1 = MALE

2 = FEMALE (NO GROUND INDENTS)

PC MOUNT _____

3 = NICKEL SHELL _____

HARDWARE OPTIONS: _____

17 = 4-40 INSERT WITH INSIDE GROUND STRAP

53 = 4-40 INSERT WITH BOARD LOCKS

56 = 4-40 STANDOFFS WITH BOARD LOCKS

PLATING: _____

1 = GOLD FLASH

NUMBER OF CONTACTS	"A"	"B"	"C"	"D"
	Inch (mm)	Inch (mm)	Inch (mm)	Inch (mm)
15	1.214 (30.84)	.984 (24.99)	.405 (10.29)	.090 (2.29)
26	1.545 (39.24)	1.312 (33.32)	.765 (19.43)	.090 (2.29)
44	2.088 (53.04)	1.852 (47.04)	1.305 (33.15)	.090 (2.29)
62	2.730 (69.34)	2.500 (63.50)	1.948 (49.47)	.095 (2.41)
78	2.635 (66.93)	2.406 (61.11)	1.805 (45.85)	.095 (2.41)

	THESE DRAWINGS AND SPECIFICATIONS ARE THE PROPERTY OF NorComp AND SHALL NOT BE REPRODUCED, COPIED OR USED AS THE BASIS FOR THE MANUFACTURE OF SALE OF APPARATUS WITHOUT WRITTEN PERMISSION.		DRAWN: PAM JENKINS	DATE: 9-15-05
			CHECKED:	DATE:
<h1>NorComp</h1>		SCALE:	SHEET 1 OF 1	REV 1
		DWG NO. 194-XXX-113LXX1		

DESCRIPTION: HIGH DENSITY RIGHT ANGLE MALE FOOTPRINT

78 POSITION MALE

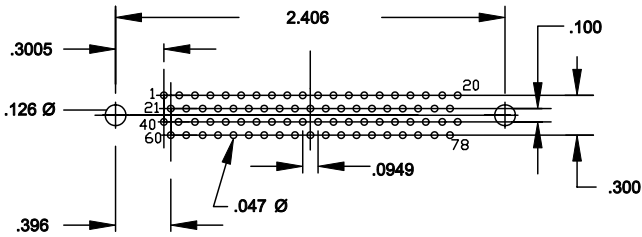

26 POSITION MALE

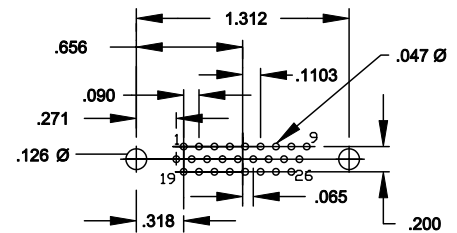

62 POSITION MALE

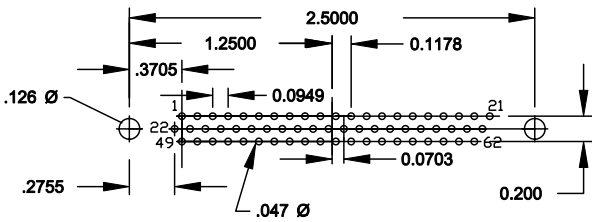

15 POSITION MALE

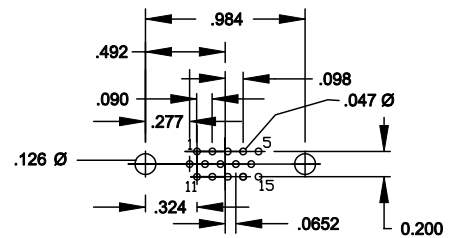

44 POSITION MALE

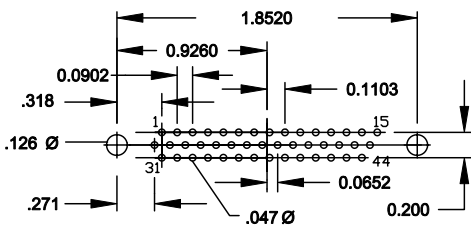

	THESE DRAWINGS AND SPECIFICATIONS ARE THE PROPERTY OF NorComp AND SHALL NOT BE REPRODUCED, COPIED OR USED AS THE BASIS FOR THE MANUFACTURE OF SALE OF APPARATUS WITHOUT WRITTEN PERMISSION.		DRAWN: PAM JENKINS	DATE: 10-29-01
			CHECKED:	DATE:
<h1>NorComp</h1>	SCALE:	SHEET 1 OF 1	REV 4	
	DWG NO. HIGH DENSITY RIGHT ANGLE MALE FOOTPRINT			