

2.4 GHz Front-End Module

SST12LF01



Data Sheet

FEATURES:

- **Gain:**
 - Typically 12 dB gain across 2.4–2.5 GHz for Receiver (RX) chain.
 - Typically 29 dB gain across 2.4–2.5 GHz over temperature 0°C to +80°C for Transmitter (TX) chain.
- **Low-Noise Figure**
 - Typical 1.45 dB across 2.4–2.55 GHz
- **50 Ω Input/Output matched along RX chain.**
- **IIP3**
 - >1 dbm across 2.4–2.55 GHz
- **High linear output power:**
 - >26.5 dBm P1dB
 - Meets 802.11g OFDM ACPR requirement up to 23 dBm
 - ~3% added EVM up to 19 dBm for 54 Mbps 802.11g signal
 - Meets 802.11b ACPR requirement up to 24 dBm
- **High power-added efficiency/Low operating current for both 802.11g/b applications**
 - ~22%/210 mA @ P_{OUT} = 22 dBm for 802.11g
 - ~26%/240 mA @ P_{OUT} = 23.5 dBm for 802.11b
- **Low idle current**
 - ~70 mA I_{CQ}
- **Low shut-down current (Typical 2.5 μA)**
- **Built-in, Ultra-low I_{REF} power-up/down control**
 - I_{REF} <4 mA
- **High-speed power-up/down**
 - Turn on/off time (10%- 90%) <100 ns
 - Typical power-up/down delay with driver delay included <200 ns
- **High temperature stability**
 - ~1 dB gain/power variation between 0°C to +85°C
- **Simple input/output matching**
- **Single positive power supply**
- **Packages available**
 - 24-contact WQFN – 4mm x 4mm
- **All non-Pb (lead-free) devices are RoHS compliant**

APPLICATIONS:

- **WLAN**
- **Bluetooth**
- **Wireless Network**

PRODUCT DESCRIPTION

The SST12LF01 is a 2.4 GHz Front-End Module (FEM) that combines a high-performance Low-Noise Amplifier (LNA) and a Power Amplifier (PA).

Designed in compliance with IEEE 802.11 b/g applications and based on GaAs PHEMT/HBT technology, the SST12LF01 operates within the frequency range of 2.4–2.55 GHz at a very low DC-current consumption. There are two components to the FEM: the Receiver (RX) chain and the Transmitter (TX) chain.

The RX chain consist of a cost effective Low-Noise Amplifier (LNA) cell which requires no external RF-matching components. This device is based on the 0.5m GaAs PHEMT technology, and complies with 802.11 b/g applications.

The LNA provides high-performance, low-noise, and moderate gain operation within the 2.4–2.55 GHz frequency band. Across this frequency band, the LNA typically provides 12 dB gain and 1.45 dB noise figure.

This LNA cell is designed with a self DC-biasing scheme, which maintains low DC current consumption, nominally at 11 mA, during operation. Optimum performance is

achieved with only a single power supply and no external bias resistors or networks are required. The input and output ports are singled-ended 50 Ohm matched. RF ports are also DC isolated requiring no dc blocking capacitors or matching components to reduce system board Bill of Materials (BOM) cost.

The TX chain includes a high-efficiency PA based on InGaP/GaAs HBT technology. The PA typically provides 30 dB gain with 22% power-added efficiency at P_{OUT} = 22 dBm for 802.11g and 27% power-added efficiency at P_{OUT} = 24 dBm for 802.11b.

The Transmitter chain has excellent linearity, typically <4% added EVM up to 20 dBm output power, which is essential for 54 Mbps 802.11g operation while meeting 802.11g spectrum mask at 23 dBm.

The SST12LF01 is offered in 24-contact WQFN package. See Figure 2 for pin assignments and Table 1 for pin descriptions.



Data Sheet

FUNCTIONAL BLOCKS

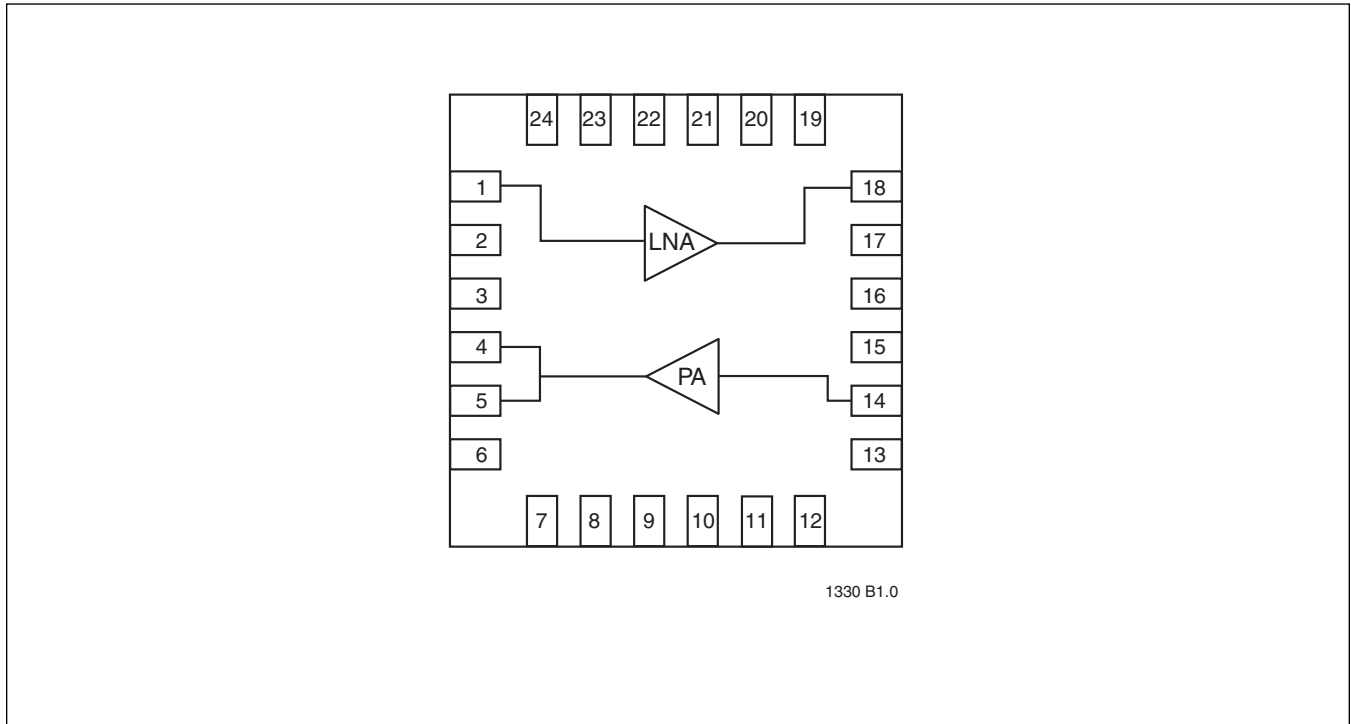

1330 B1.0

FIGURE 1: Functional Block Diagram

PIN ASSIGNMENTS

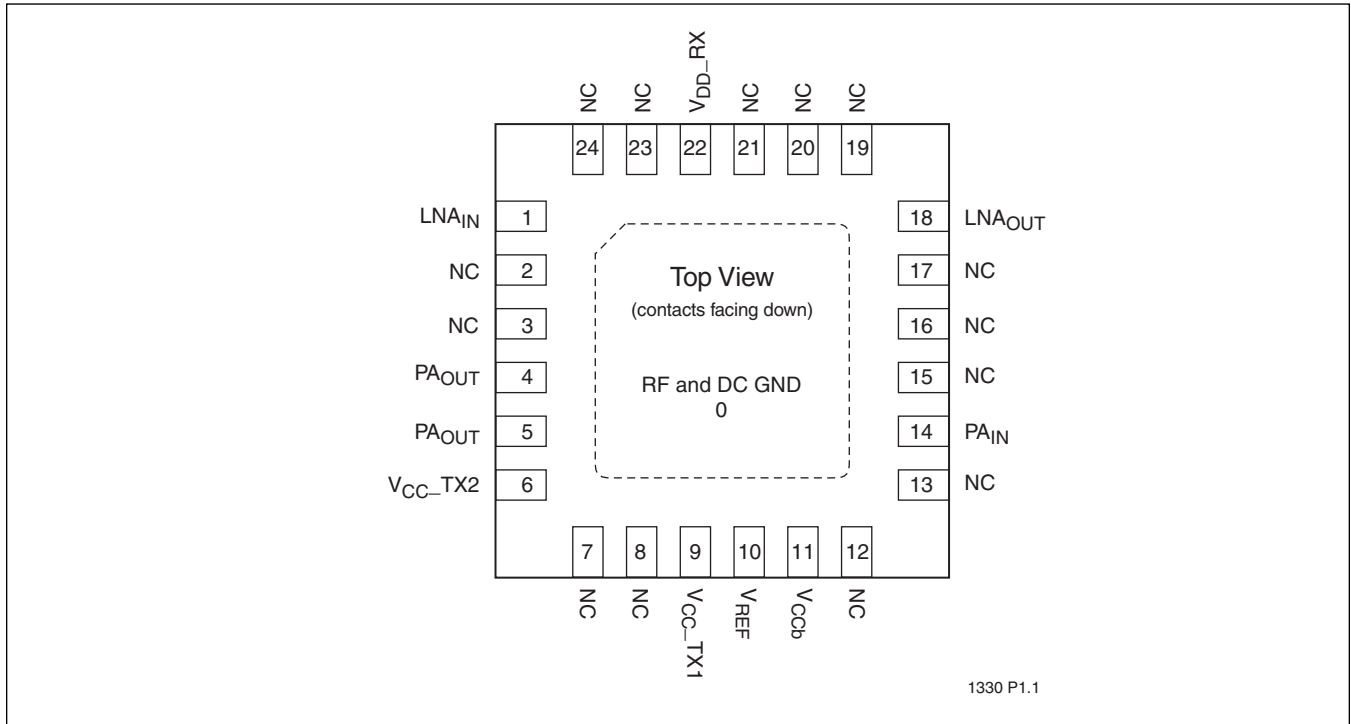

FIGURE 2: Pin Assignments for 24-contact WQFN



Data Sheet

PIN DESCRIPTIONS

TABLE 1: Pin Description

Symbol	Pin No.	Pin Name	Type ¹	Function
LNA _{IN}	1		I	LNA RF Input
NC	2	No Connection		Unconnected pin
NC	3	No Connection		Unconnected pin
PA _{OUT}	4		O	PA RF output
PA _{OUT}	5		O	PA RF output
V _{CC_TX2}	6	Power Supply	PWR	PA power supply, 2 nd stage
NC	7	No Connection		Unconnected pin
NC	8	No Connection		Unconnected pin
V _{CC_TX1}	9	Power Supply	PWR	PA power supply, 1 st stage
V _{REF}	10		PWR	PA-enable and current control
V _{CCb}	11	Power Supply	PWR	PA power supply, bias circuit
NC	12	No Connection		Unconnected pin
NC	13	No Connection		Unconnected pin
PA _{IN}	14		I	PA RF input
NC	15	No Connection		Unconnected pin
NC	16	No Connection		Unconnected pin
NC	17	No Connection		Unconnected pin
LNA _{OUT}	18		O	LNA RF Output
NC	19	No Connection		Unconnected pin
NC	20	No Connection		Unconnected pin
NC	21	No Connection		Unconnected pin
V _{DD_RX}	22	Power Supply	PWR	LNA power supply
NC	23	No Connection		Unconnected pin
NC	24	No Connection		Unconnected pin

1. I=Input, O=Output

T1.0 1330



2.4 GHz Front-End Module SST12LF01

Data Sheet

ELECTRICAL SPECIFICATIONS

The AC and DC specifications for the power amplifier interface signals. Refer to Table 2 for the DC voltage and current specifications. Refer to Figures 3 through 14 for the RF performance.

Absolute Maximum Stress Ratings (Applied conditions greater than those listed under “Absolute Maximum Stress Ratings” may cause permanent damage to the device. This is a stress rating only and functional operation of the device at these conditions or conditions greater than those defined in the operational sections of this data sheet is not implied. Exposure to absolute maximum stress rating conditions may affect device reliability.)

Input power to pins 1 (LNA)	0 dBm
Input power to pins 14 (PA)	-5 dBm
Average output power pins 4 and 5 (P_{OUT}) ¹	24 dBm
Average output power pin 18 (P_{OUT}) ¹	9 dBm
Supply Voltage at pins 6, 9, and 11 (V_{CC})	-0.3V to +3.5V
Supply Voltage at pin 22 (V_{DD})	-0.3V to +4.6V
Reference voltage to pin 10 (V_{REF})	-0.3V to +3.6V
DC supply current to pin 10 (I_{DD})	14 mA
DC supply current to pin 6, 9, and 11 (I_{CC})	300 mA
Operating Temperature (T_A)	-40°C to +85°C
Storage Temperature (T_{STG})	-40°C to +120°C
Maximum Junction Temperature (T_J)	+150°C
Surface Mount Solder Reflow Temperature	260°C for 10 seconds

1. Never measure with CW source. Pulsed single-tone source with <50% duty cycle is recommended. Exceeding the maximum rating of average output power could cause permanent damage to the device.

Operating Range

Range	Ambient Temp	V_{CC} / V_{DD}
Commercial	-0 to 80°C	2.9–3.5V

TABLE 2: DC Electrical Characteristics

Symbol	Parameter	Min.	Typ	Max.	Unit
V_{CC}	Supply Voltage at pins 6, 9, 11, and 22		3.3	4.2	V
I_{CC}	Supply Current at pin 22		10		mA
	for 802.11g, 22 dBm at pins 6, 9, and 11		210		mA
	for 802.11b, 23.5 dBm at pins 6, 9, and 11		260		mA
I_{CQ}	Idle current for 802.11g to meet EVM<4% @ 20 dBm		75		mA
I_{OFF}	Shut down current		2.5		μA
V_{REF} ¹	Reference Voltage at pin10 with $R_{REG} = 0\Omega$ resistor		2.7		V
	Reference Voltage at pin 10 with $R_{REG} = 120\Omega$ resistor	2.7	2.9	3.1	V
	Reference Voltage at pin 10 with $R_{REG} = 220\Omega$ resistor	2.9	3.1	3.3	V

T2.1 1330

1. V_{REF} and V_{REG} are defined in Figure 15. Three combinations of resistor values and applied voltages of V_{REG} are suggested in Table 2.



2.4 GHz Front-End Module SST12LF01

Data Sheet

TABLE 3: AC Electrical Characteristics for RX Chain

Symbol	Parameter	Min.	Typ	Max.	Unit
F _{L-U}	Frequency range	2400		2550	MHz
G	Small signal gain	10	12		dB
NF	Noise Figure		1.45		dB
IIP3	2.4–2.55 GHz	1	3		dBm

T3.1 1330

TABLE 4: AC Electrical Characteristics for TX Chain

Symbol	Parameter	Min.	Typ	Max.	Unit
F _{L-U}	Frequency range	2400		2485	MHz
P _{OUT}	Output power				
	@ PIN = -6 dBm 11b signals	23			dBm
	@ PIN = -9 dBm 11g signals	20			dBm
G	Small signal gain	28	29	33	dB
G _{VAR1}	Gain variation over band (2400~2485 MHz)			±0.5	dB
G _{VAR2}	Gain ripple over channel (20 MHz)		0.2		dB
ACPR	Meet 11b spectrum mask	23			dBm
	Meet 11g OFDM 54 Mbps spectrum mask	22			dBm
Added EVM	@ 20 dBm output with 11g OFDM 54 Mbps signal		4		%
2f, 3f, 4f, 5f	Harmonics at 22 dBm, without external filters			-40	dBc

T4.1 1330

TYPICAL PERFORMANCE CHARACTERISTICS

Test Conditions: $V_{DD} = 3.0V$, $T_A = 25^\circ C$, unless otherwise specified

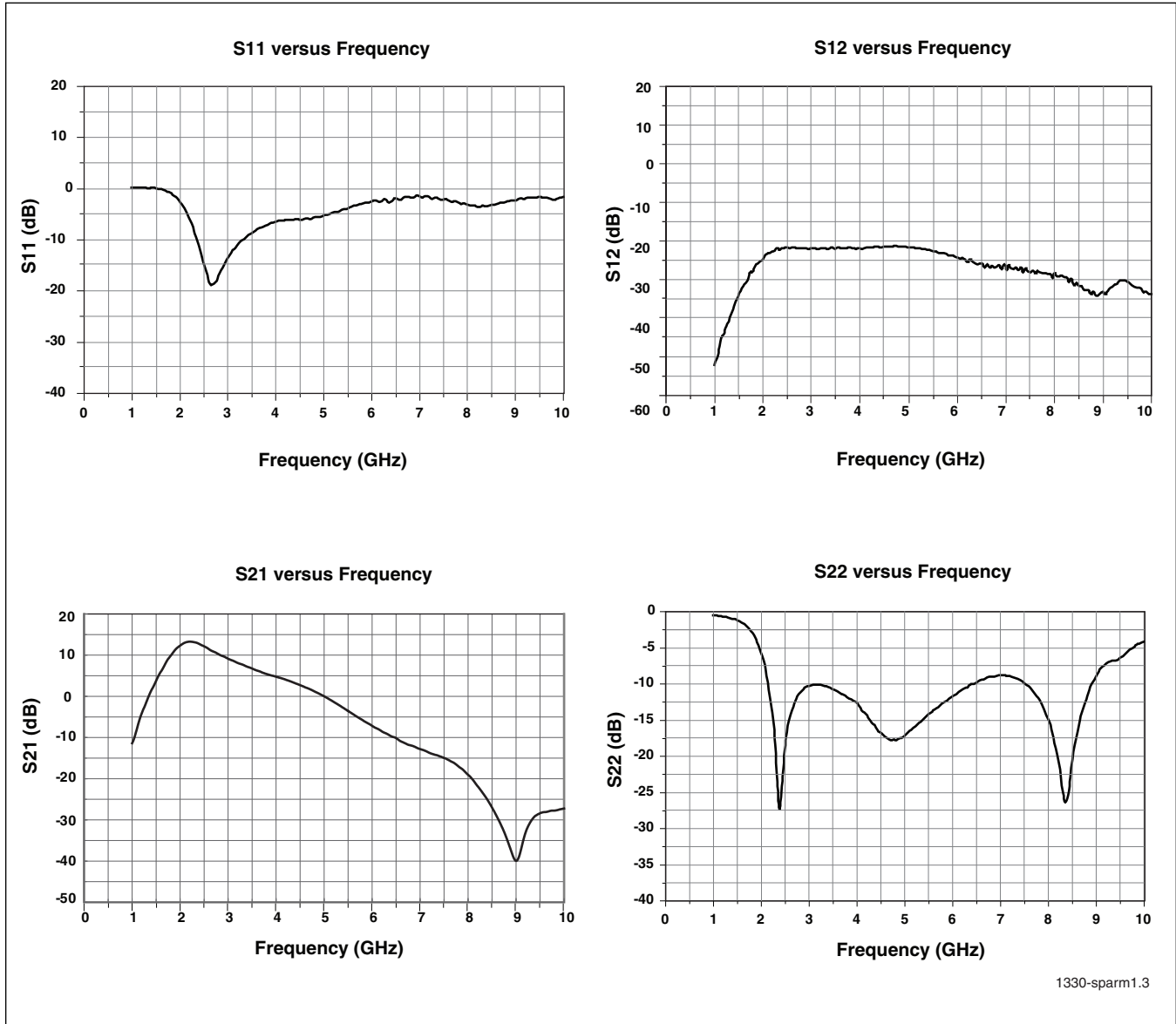

FIGURE 3: S-Parameters, RX Chain

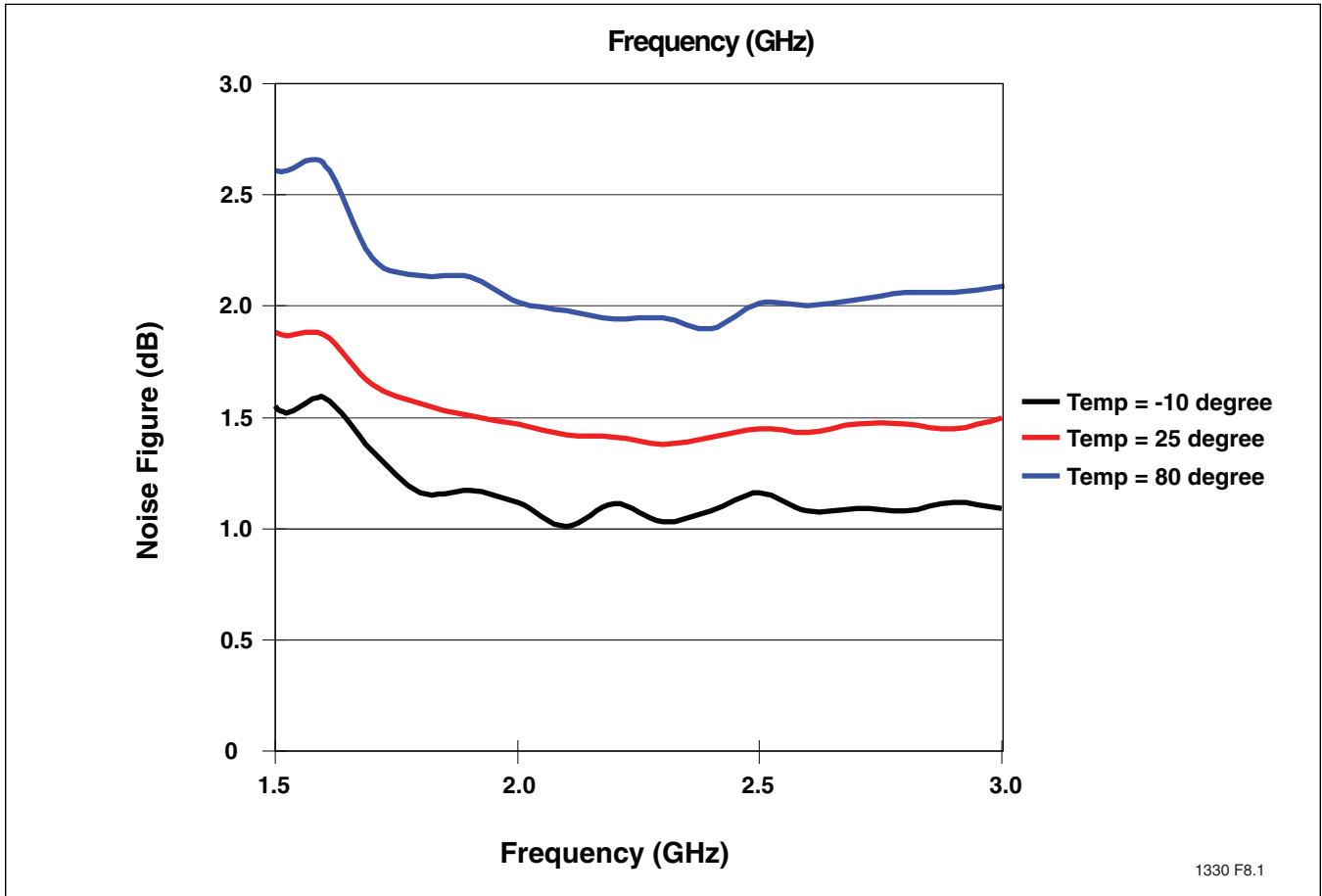

FIGURE 4: Noise Figure versus Frequency, RX Chain

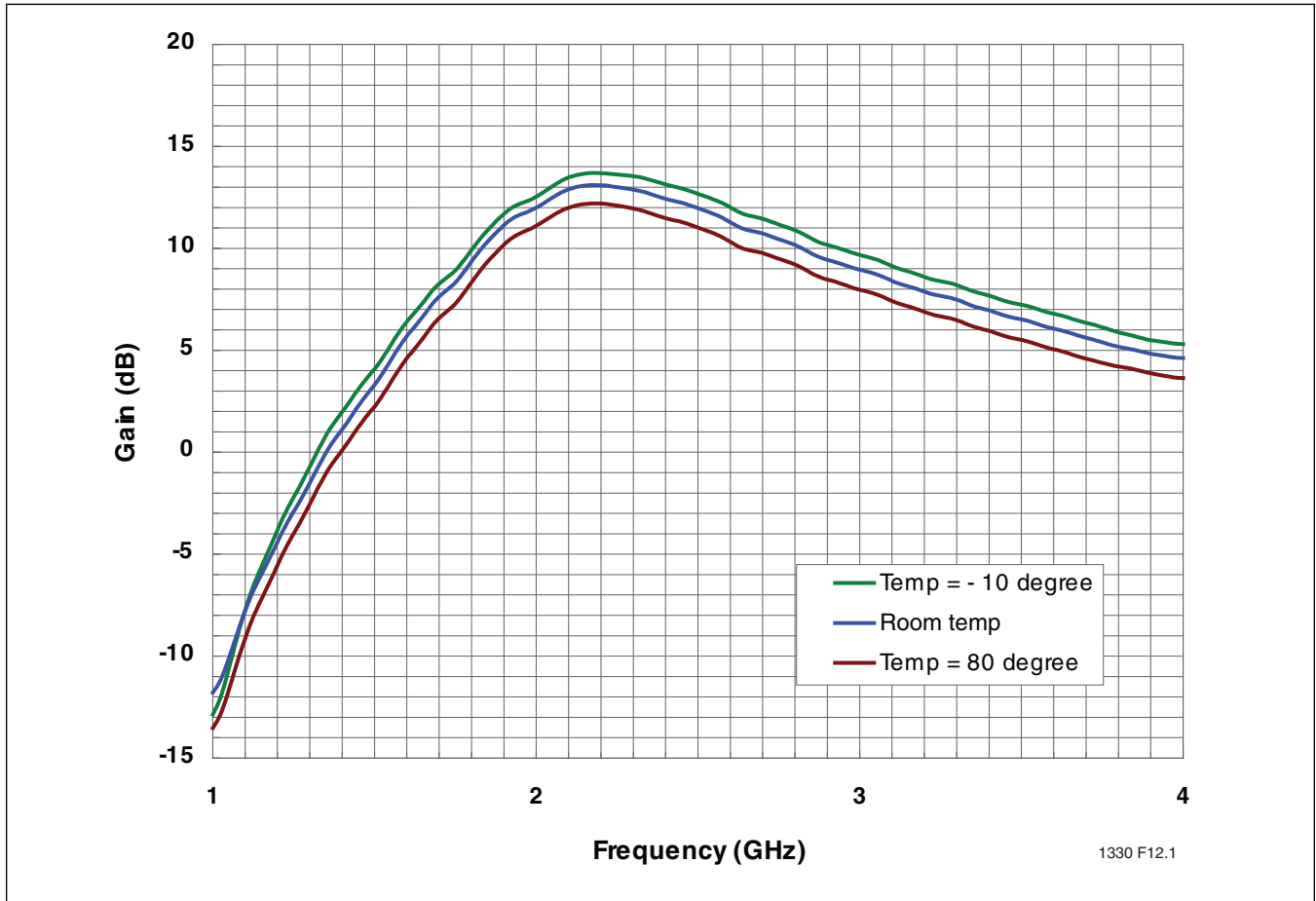

FIGURE 5: Frequency Response of Gain (S21) over three Temperatures

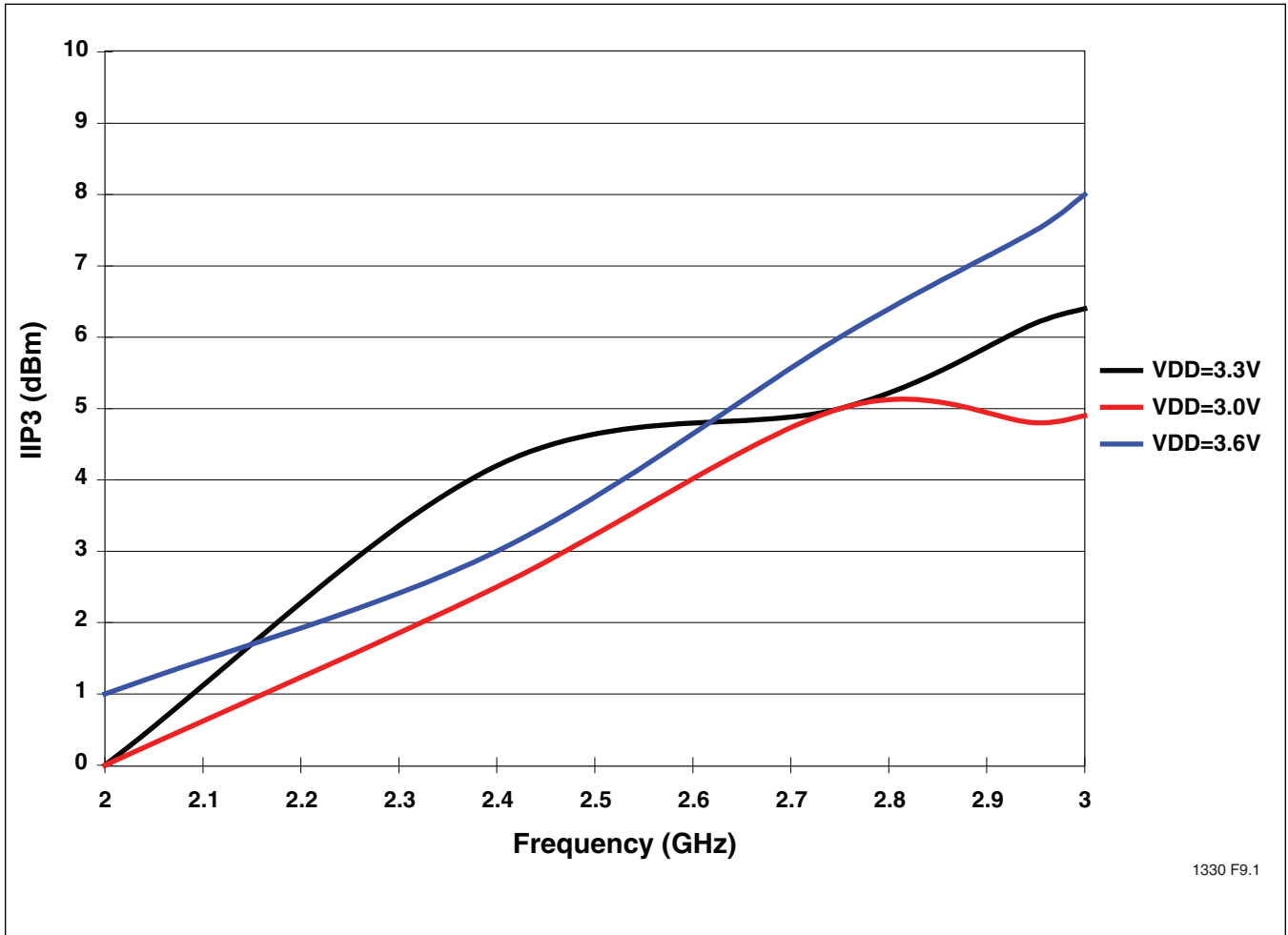

FIGURE 6: Input IP3 versus Frequency, RX Chain

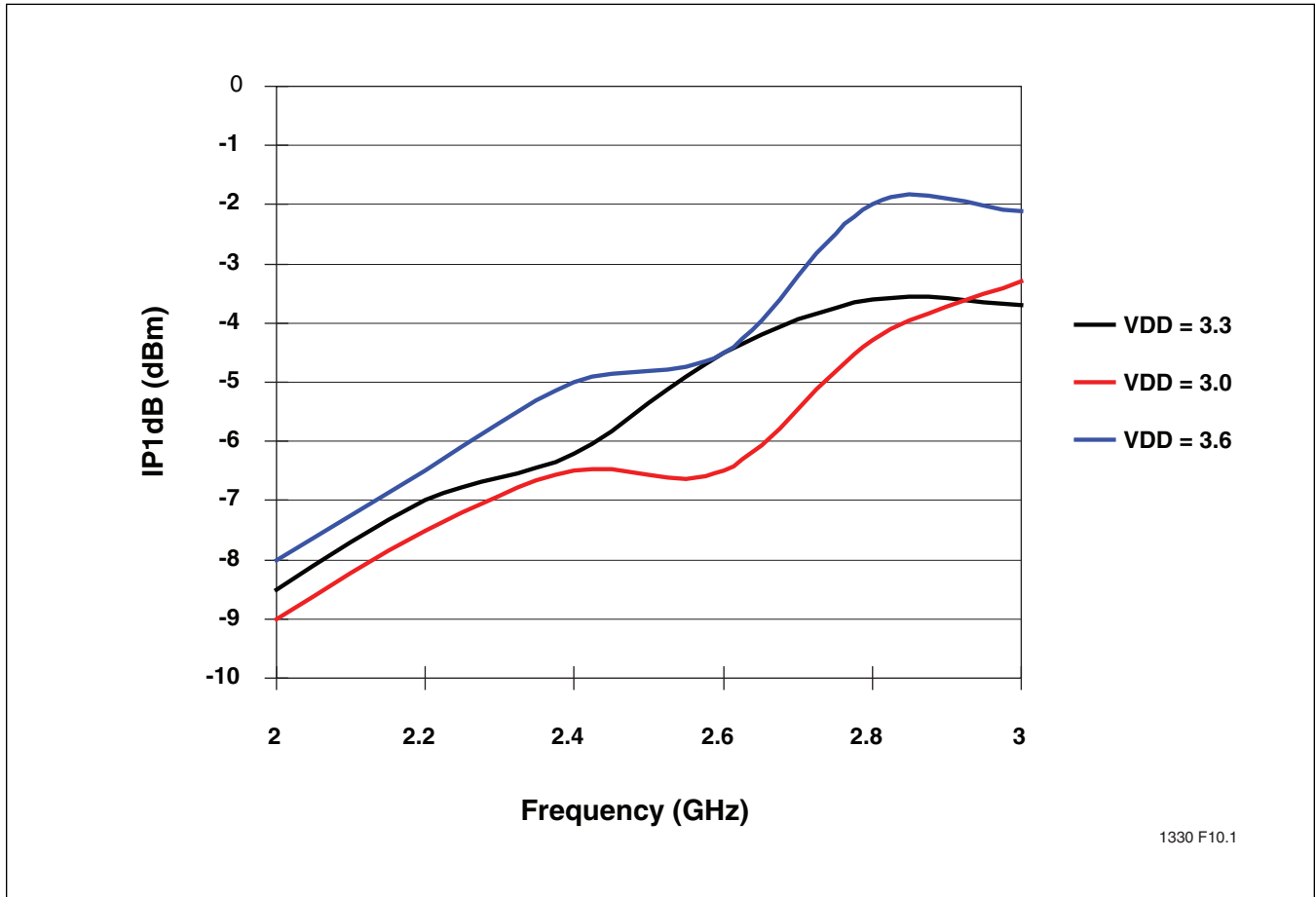

FIGURE 7: Input P1dB versus Frequency, RX Chain



Data Sheet

Test Conditions: $V_{CC} = 3.3V$, $T_A = 25^\circ C$, unless otherwise specified

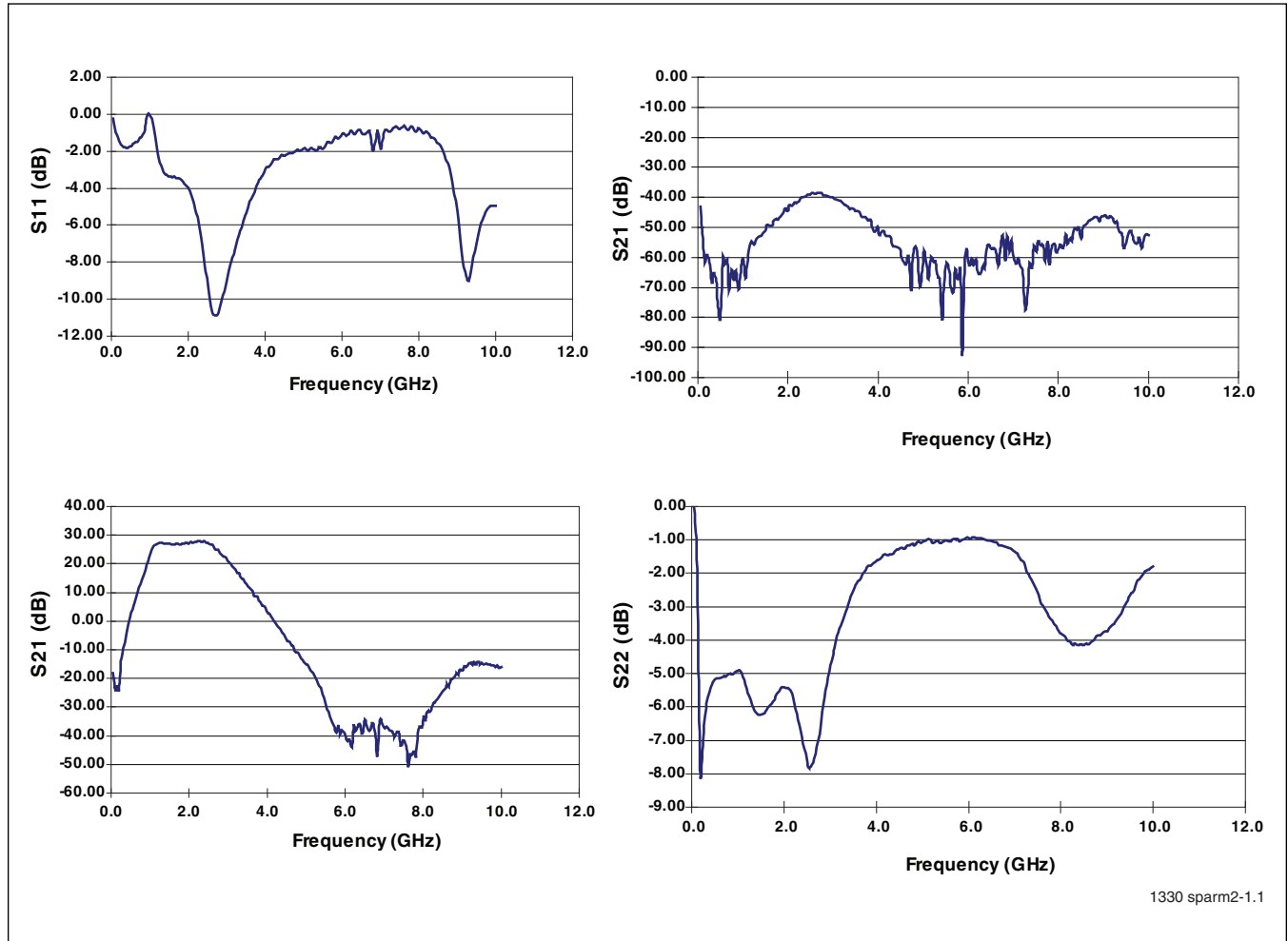

FIGURE 8: S-Parameters, TX Chain

TYPICAL PERFORMANCE CHARACTERISTICS

Test Conditions: $f = 2.447 \text{ GHz}$, $V_{CC} = 3.3\text{V}$, $V_{REF} = 2.85\text{V}$ at Room Temperature $I_{CQ} = 70 \text{ mA}$

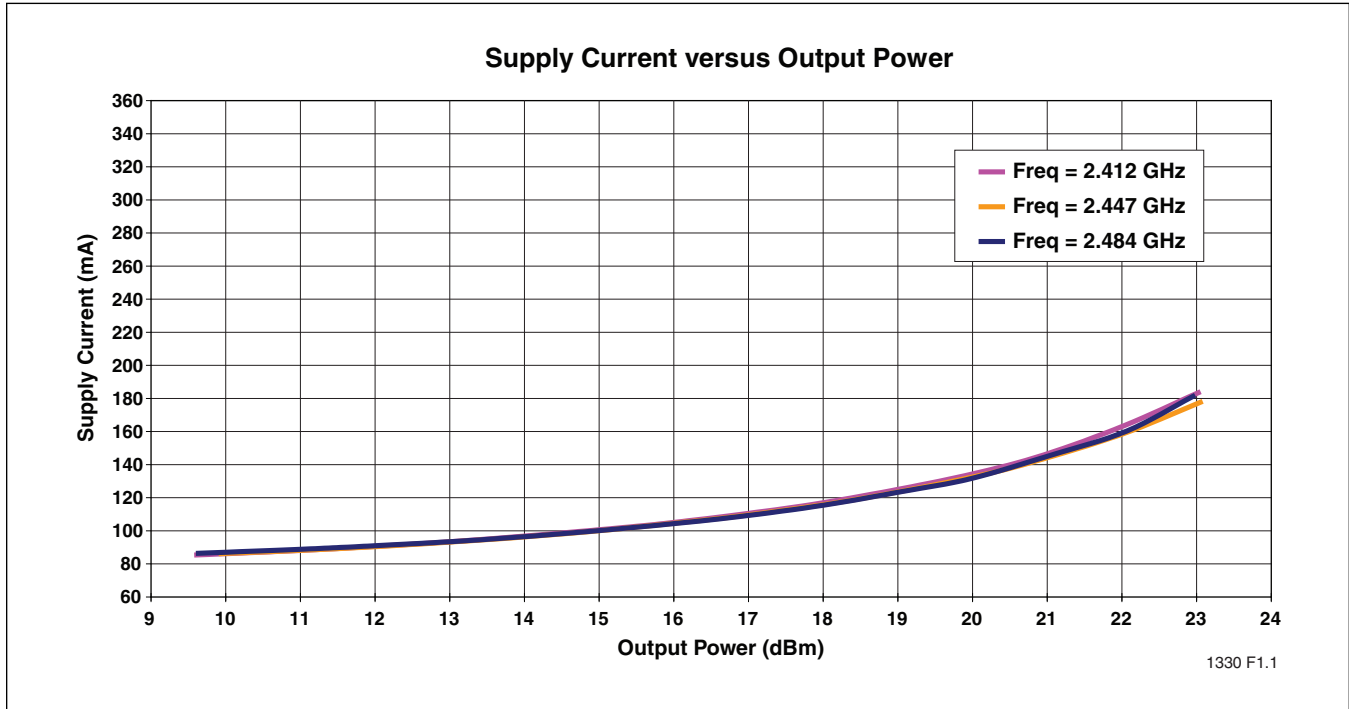

FIGURE 9: Supply Current versus Output Power

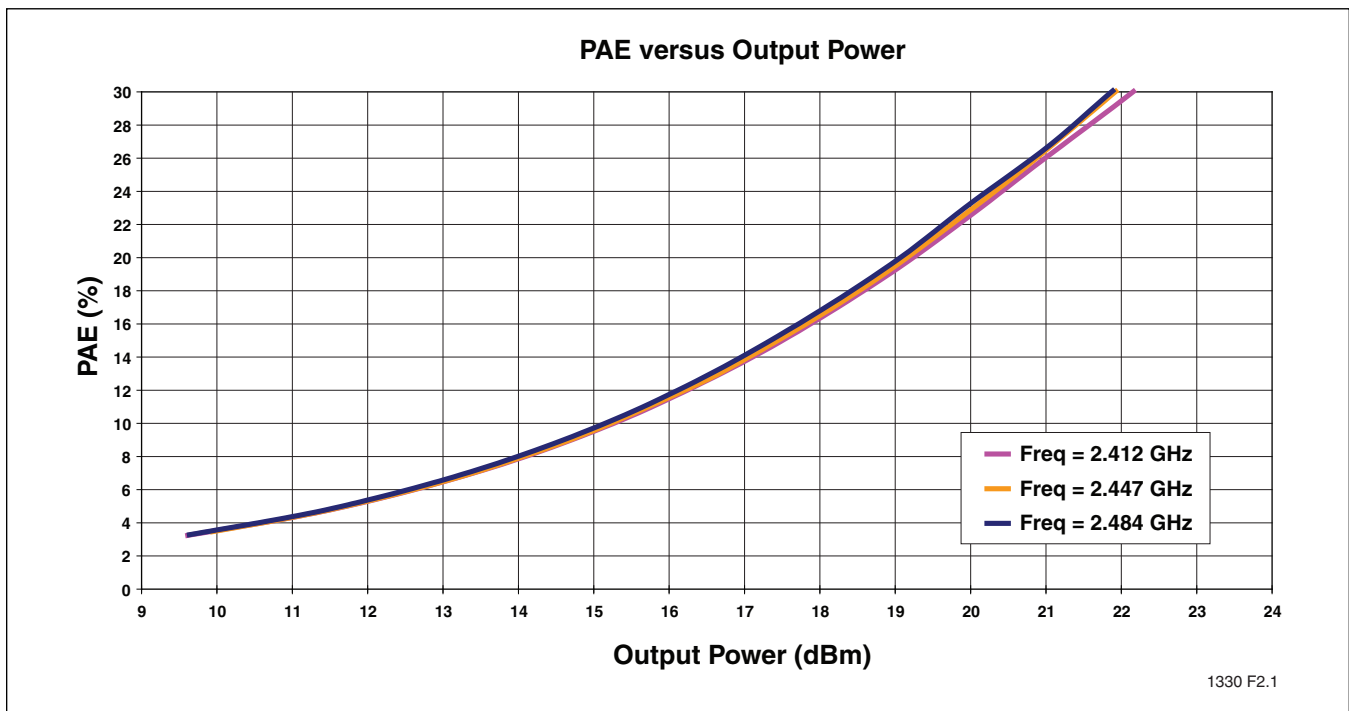

FIGURE 10: Power Added Efficiency (PAE) versus Output Power

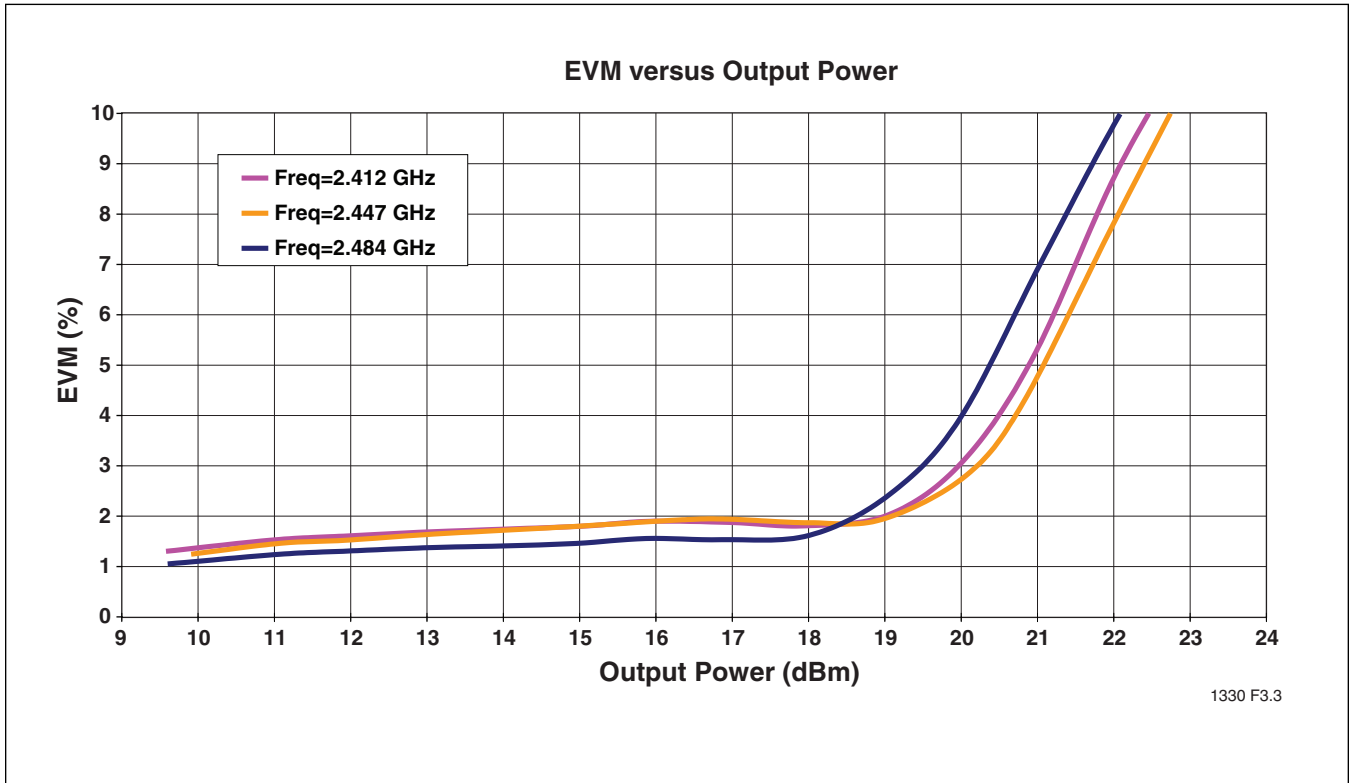

FIGURE 11: EVM versus Output Power

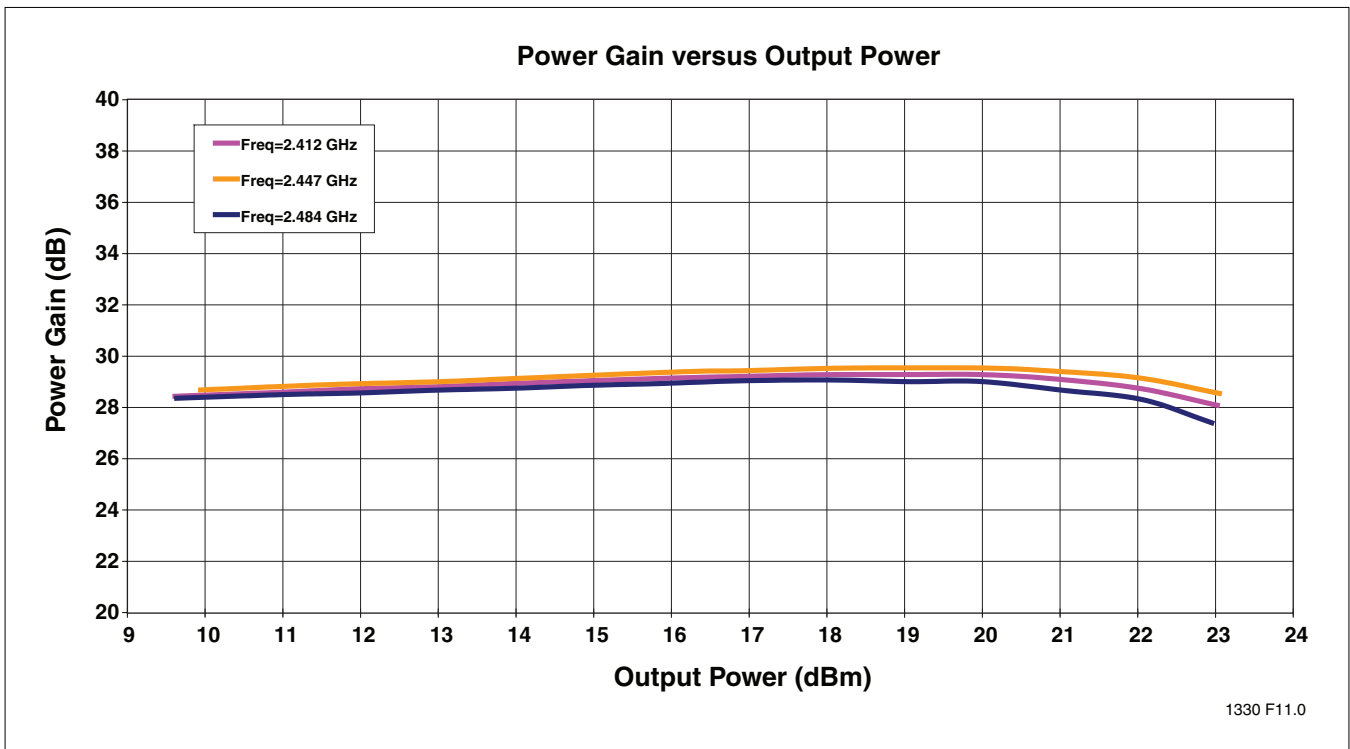

FIGURE 12: Power Gain versus Output Power

TEST CONDITIONS: $V_{CC} = 3.3V$, $T_A = 25^\circ C$, 54 MBPS 802.11G OFDM SIGNAL

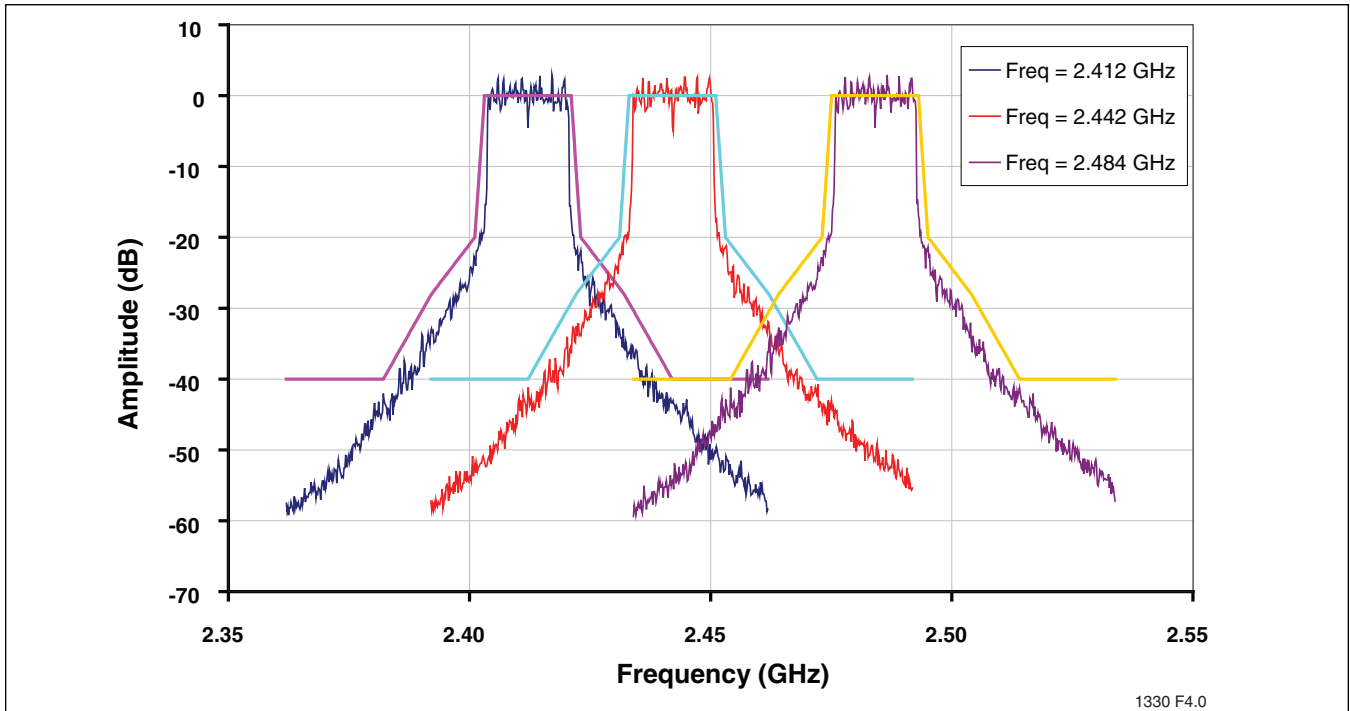

FIGURE 13: 802.11g Spectrum Mask at 23 dBm

Test Conditions: $V_{CC} = 3.3V$, $T_A = 25^\circ C$, 1 Mbps 802.11b signal

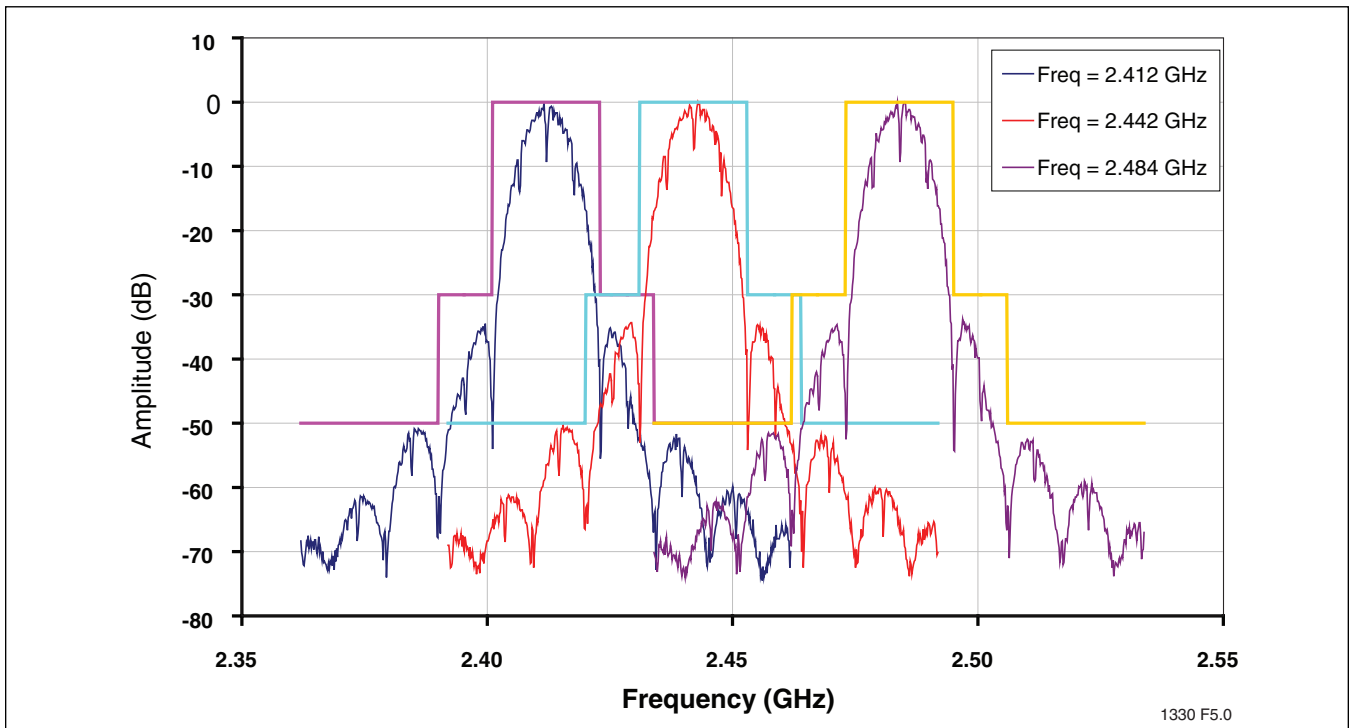

FIGURE 14: 802.11b Spectrum Mask at 23 dBm



2.4 GHz Front-End Module SST12LF01

Data Sheet

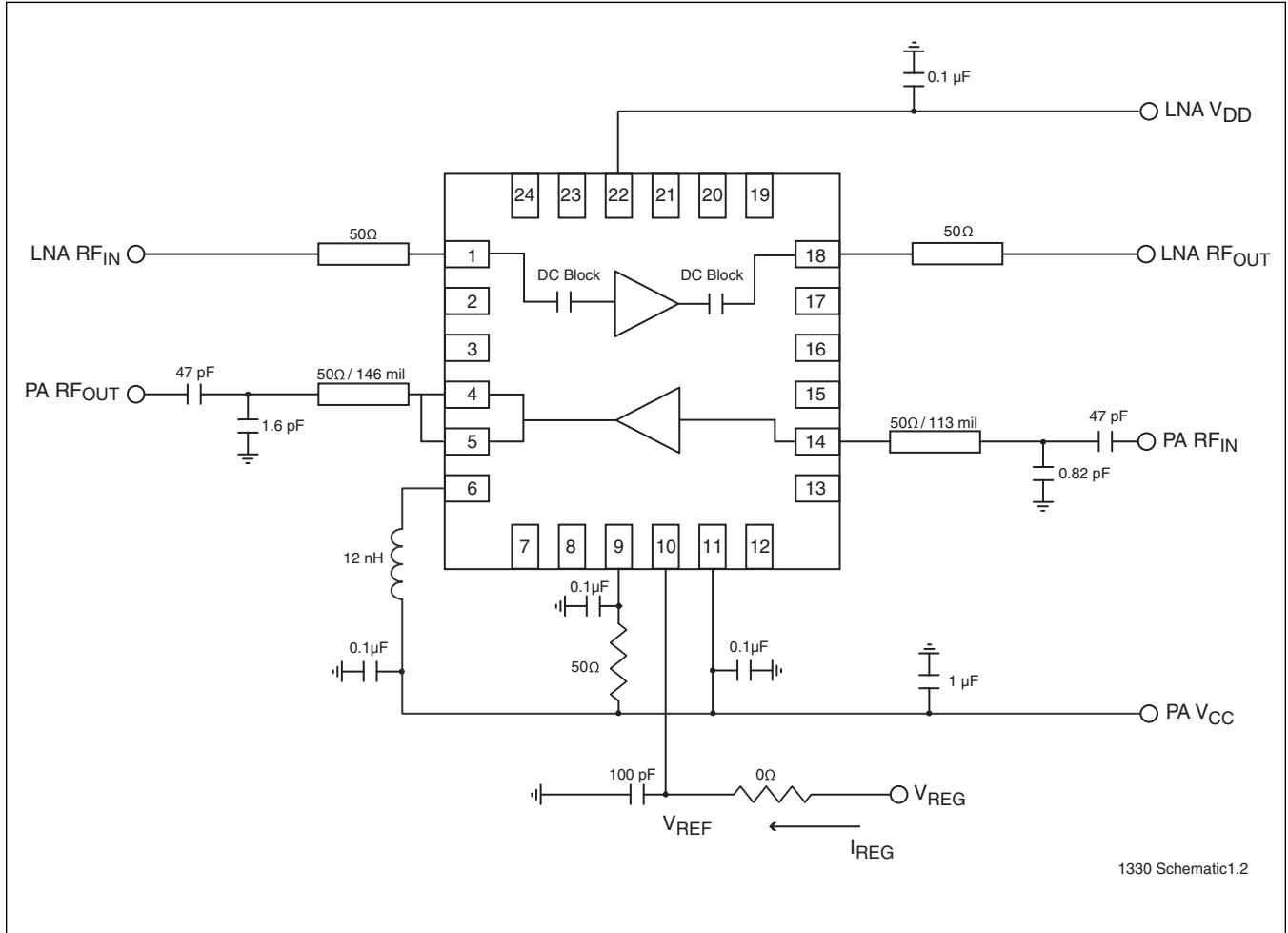

FIGURE 15: Typical Schematic



2.4 GHz Front-End Module SST12LF01

Data Sheet

PRODUCT ORDERING INFORMATION

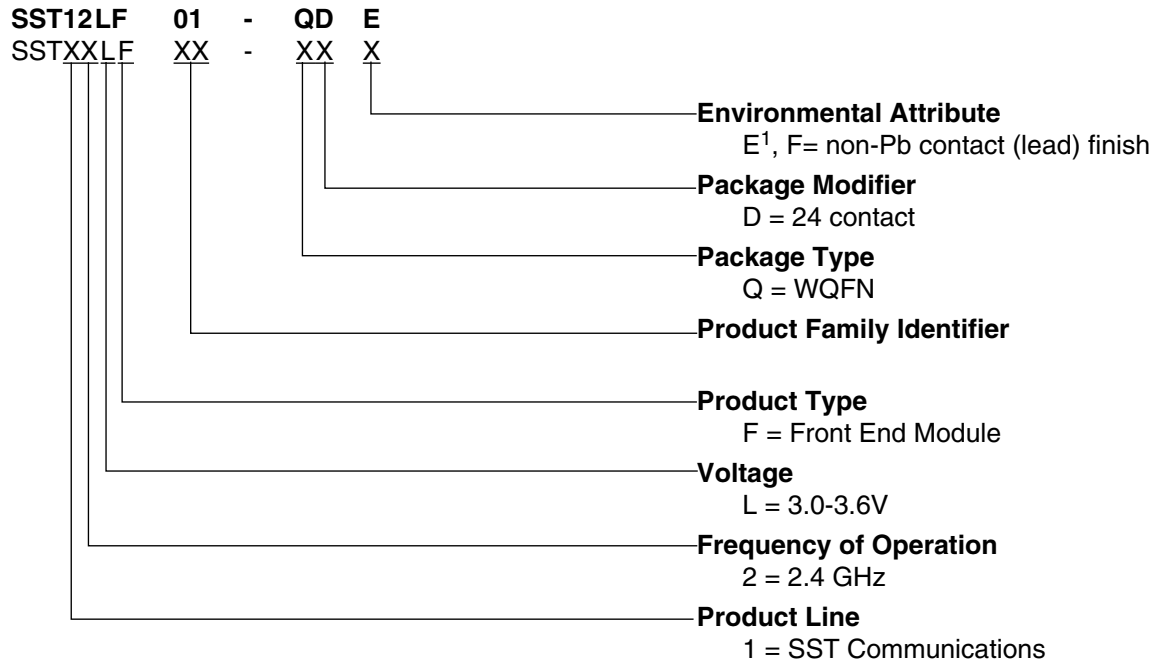

1. Environmental suffixes "E" and "F" denote non-Pb solder. SST non-Pb solder devices are "RoHS Compliant".

Valid combinations for SST12LF01

SST12LF01-QDE SST12LF01-QDF

SST12LF01 Evaluation Kits

SST12LF01-QDE-K SST12LF01-QDF-K

Note: Valid combinations are those products in mass production or will be in mass production. Consult your SST sales representative to confirm availability of valid combinations and to determine availability of new combinations.



Data Sheet

PACKAGING DIAGRAMS

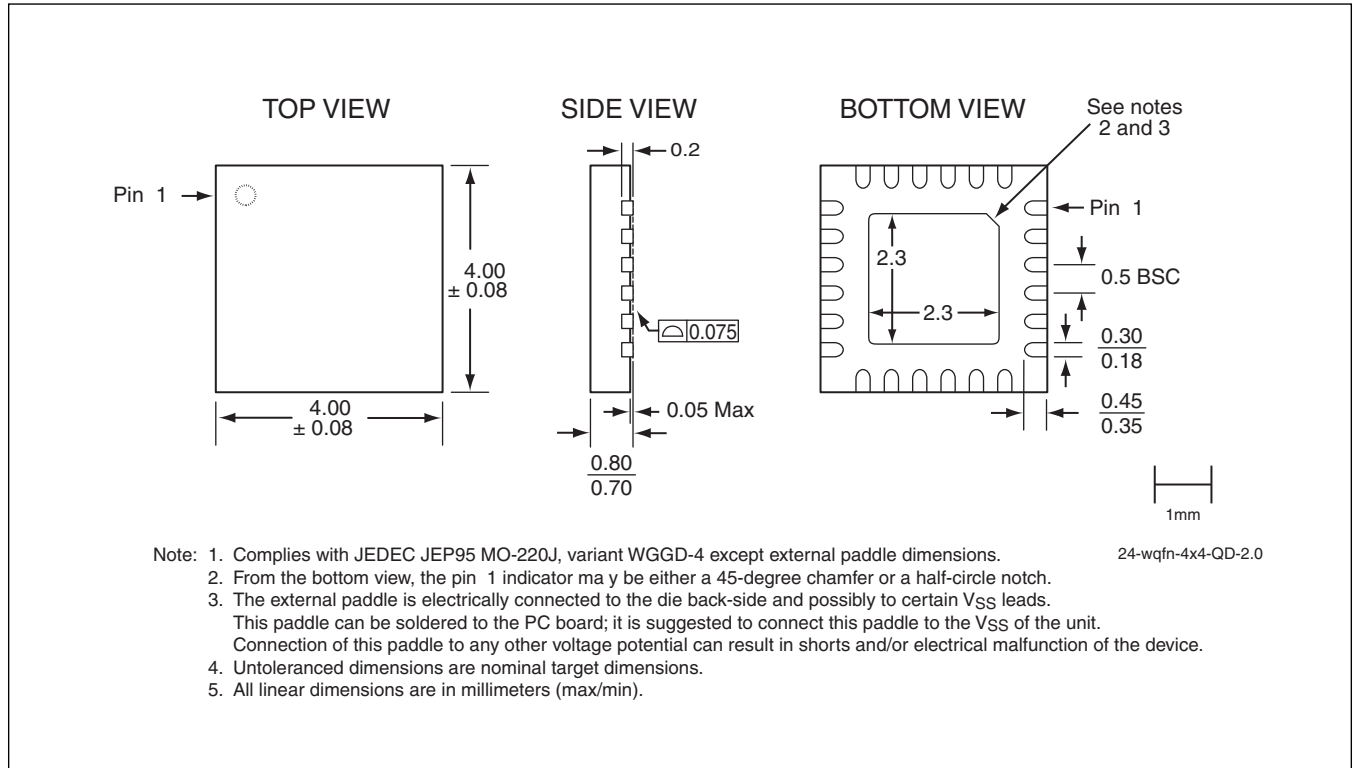

FIGURE 16: 24-contact Very-very-thin Quad Flat No-lead (WQFN)
SST Package Code: QD

2.4 GHz Front-End Module SST12LF01



Data Sheet

TABLE 5: Revision History

Revision	Description	Date
00	<ul style="list-style-type: none"> Initial release of data sheet 	Sep 2006
01	<ul style="list-style-type: none"> Updated pins 9 and 11 in Figure 2 on page 3 Updated pin 6, 9, and 11 in Table 1 on page 4 Updated Figure 11 on page 14 Updated Figure 15 on page 16 	Jan 2007
02	<ul style="list-style-type: none"> Updated "Product Ordering Information" on page 17 	Sep 2007
03	<ul style="list-style-type: none"> Revised Product Description on page 1 Changed signal gain value 14 dB globally Changed low-noise figure to 1.45 dB globally Edited high temperature stability feature, page 1 Change low idle current to 75 mA, page 1 Edited Table 2, DC Electrical Characteristics; Table 3, AC Electrical Characteristics RX Chain; Table 4, AC Electrical Characteristics TX Chain Replaced Figures 3 through 11 with up-to-date graphs on pages 7 through 13 Added Figure 5 on page 8 Added Figure 12 on page 14 Edited Figure 15 on page 16 	Jun 2008
04	<ul style="list-style-type: none"> Revised RX chain gain value from 14 to 12 in "Features:" and "Product Description" on page 1 and Table 3 on page 6. Updated Figures 3 and 5. 	Nov 2008
05	<ul style="list-style-type: none"> Updated "" on page 19 	Feb 2009
06	<ul style="list-style-type: none"> Updated document status to "Data Sheet" Revised IIPE values in Features on page 1 and Table 3 on page 6 Changed definition of "F" environmental attribute in "Product Ordering Information" on page 17 	Nov 2010