

RECOMMENDED P.C.B. LAYOUT

SWITCH FUNCTION		
POS. 1	POS. 2	POS. 3
DN	NONE	CON
2-3,5-6 8-9,11-12	OPEN	2-1,5-4 8-7,11-10

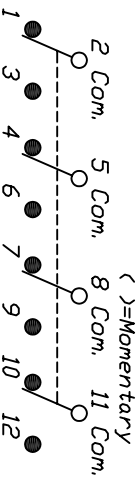

CIRCUIT: 4PDT

- NOTES:
1. ALL DIMENSIONS IN MM [INCH]
 2. GENERAL TOLERANCE: X:X=±0.4
X:XX=±0.25
 3. TERMINAL NUMBERS FOR REF ONLY
 4. RATING: 5A @120VACor 28VDC
2A @250VAC. w/resistive loads
 5. CONTACT & TERM MATERIAL:
Cu Alloy w/Silver plate.
 6. ELECTRIC LIFE: 40,000 make-and-break cycles
at full load.
 7. INSULATION RESISTANCE: 1,000 Mega-ohm min.
 8. DIELECTRIC STRENGTH: 1,000 V RMS @sea level.
 9. OPERATING TEMP.: -30°C to 85°C
 10. 2002/95/EC (ROHS) COMPLIANT

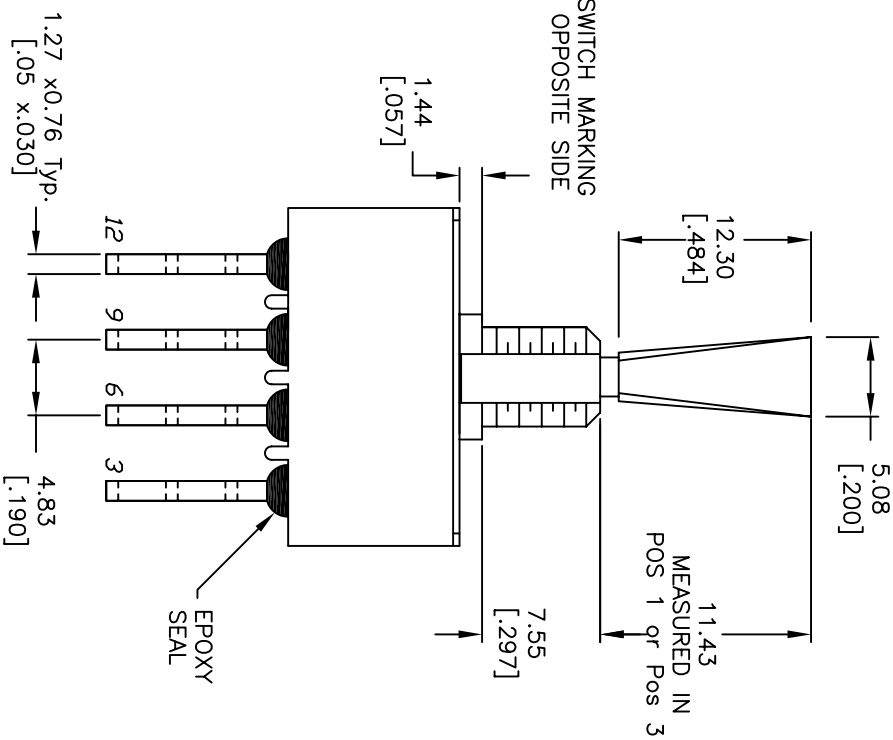
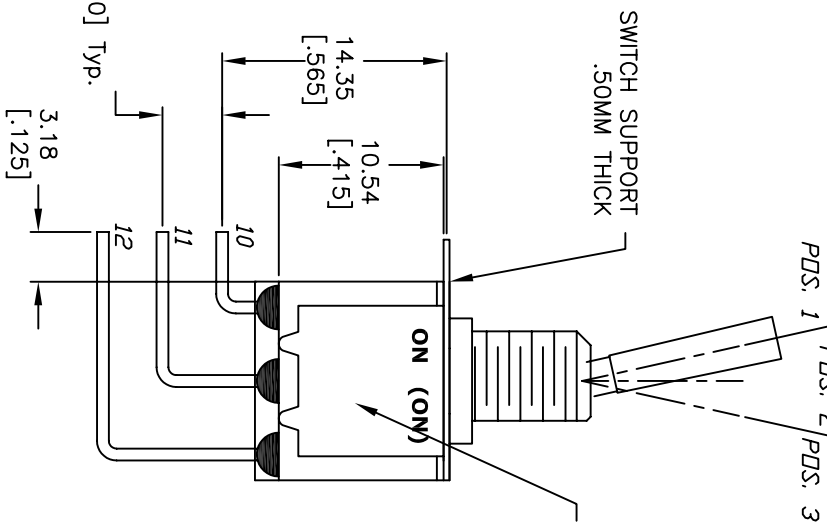
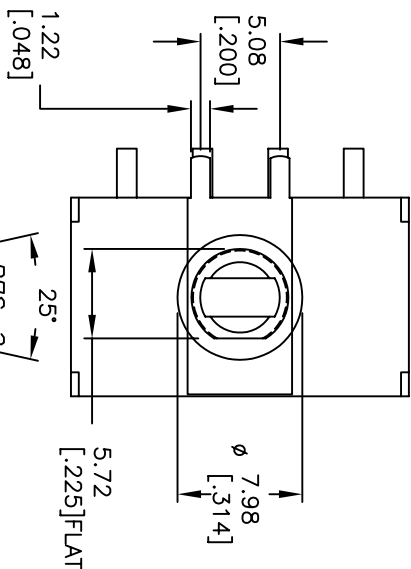

REV.	ECN No.	DESCRIPTION	DATE	CHKD
B	17121	TERMINALS FIXED, NOTES	3/19/07	TN
A	12719	REVISED SCHEMATIC	1/13/03	CJB

TITLE	SCALE	DATE	DR	DWG	REV
1004P2T6B15M7QE	2:1	3/19/07	TN	T142017	B