

RECOMMENDED P.C.B. LAYOUT

SWITCH FUNCTION		
PDS. 1	PDS. 2	PDS. 3
DN	DN	DN
2-3,5-6	DN	2-1,5-4
8-9	DPEN	8-7

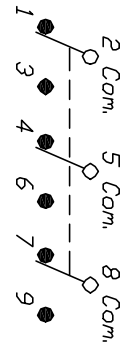
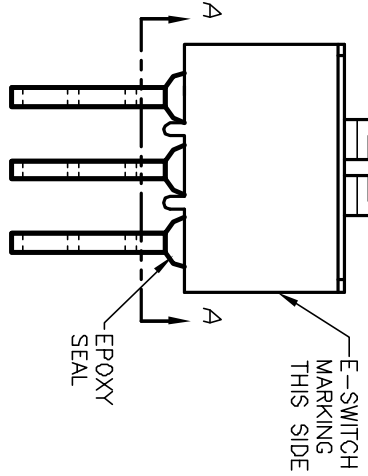
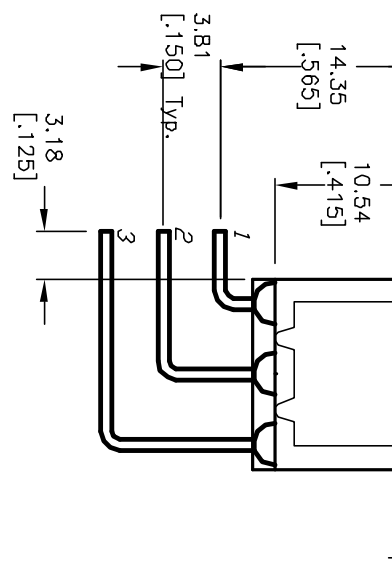
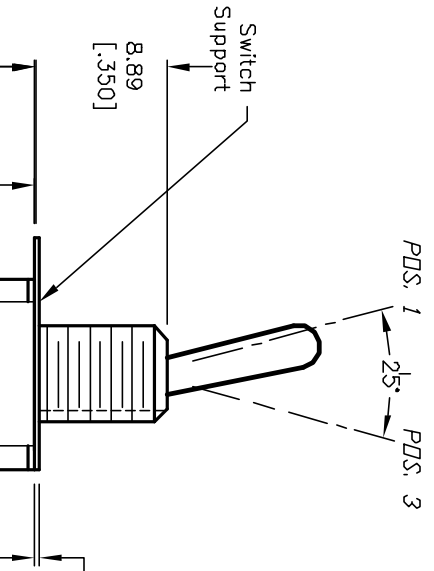

NOTES:
CIRCUIT: 3PDT

1. ALL DIMENSIONS IN MM [INCH]
2. GENERAL TOLERANCE: X.X=±0.4 X.XX=±0.25
3. TERMINAL NUMBERS FOR REF ONLY
4. RATING: 5A @120VAC or 28VDC; 2A @250VAC.
5. CONTACT MATERIAL:
Copper Alloy W/SILVER Plate
6. ELECTRIC LIFE: 50,000 make-and-break cycles at full load.
7. INSULATION RESISTANCE: 1,000 Mega-ohm min.
8. DIELECTRIC STRENGTH: 1,000 V RMS @sea level.
9. OPERATING TEMP.: -30°C to 85°C

E-SWITCH®

C	12078	REVISED AND REDRAWN	4/19/02	CJB	TITLE	100 3P-1 T1 B1 M7 Q E
REV.	ECN No.	DESCRIPTION	DATE	CHK'D	SCALE	2:1
					DATE	4/19/02
					DR	CB
					DWG	T131006
					REV	C

THE INFORMATION CONTAINED IN THIS DOCUMENT IS PROPRIETARY TO E-SWITCH AND IS NOT TO BE COPIED OR TRANSMITTED