

VIEW A-A  
CROPPED FOR CLARITY

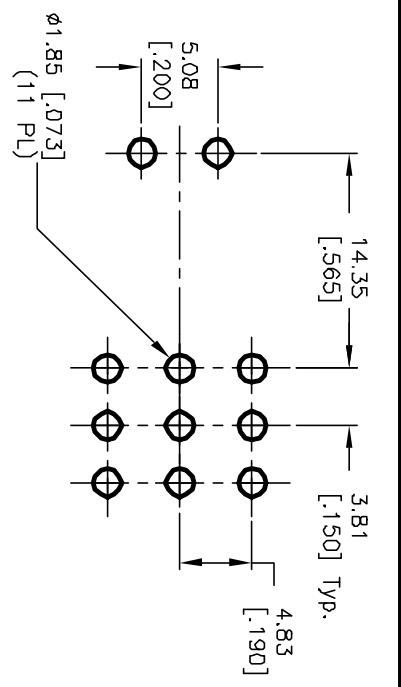

RECOMMENDED P.C.B. LAYOUT

SWITCH FUNCTION		
POS. 1	POS. 2	POS. 3
DN	NONE	DN
2-3,5-6	DPEN	2-1,5-4
8-9		8-7

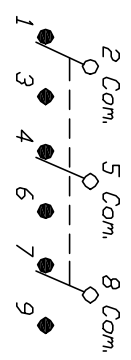

NOTES: CIRCUIT: 3PDT

1. ALL DIMENSIONS IN MM [INCH]
2. GENERAL TOLERANCE: X.X=±0.4 X.XX=±0.25
3. TERMINAL NUMBERS FOR REF ONLY
4. RATING: 5A @120V or 28VDC 2A @250V
5. CONTACT MATERIAL:  
Copper Alloy W/Silver plate
6. ELECTRIC LIFE: 50,000 make-and-break cycles at full load.
7. INSULATION RESISTANCE: 1,000 Mega-ohm min.
8. DIELECTRIC STRENGTH: 1,000 V RMS @sea level.
9. OPERATING TEMP.: -30°C to 85°C

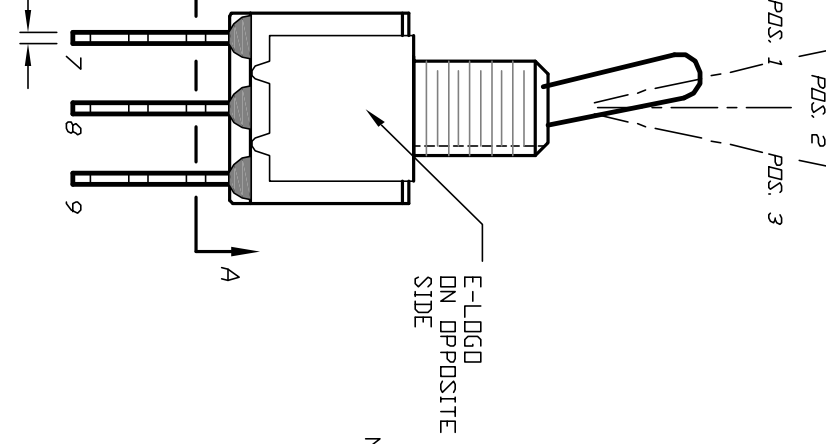
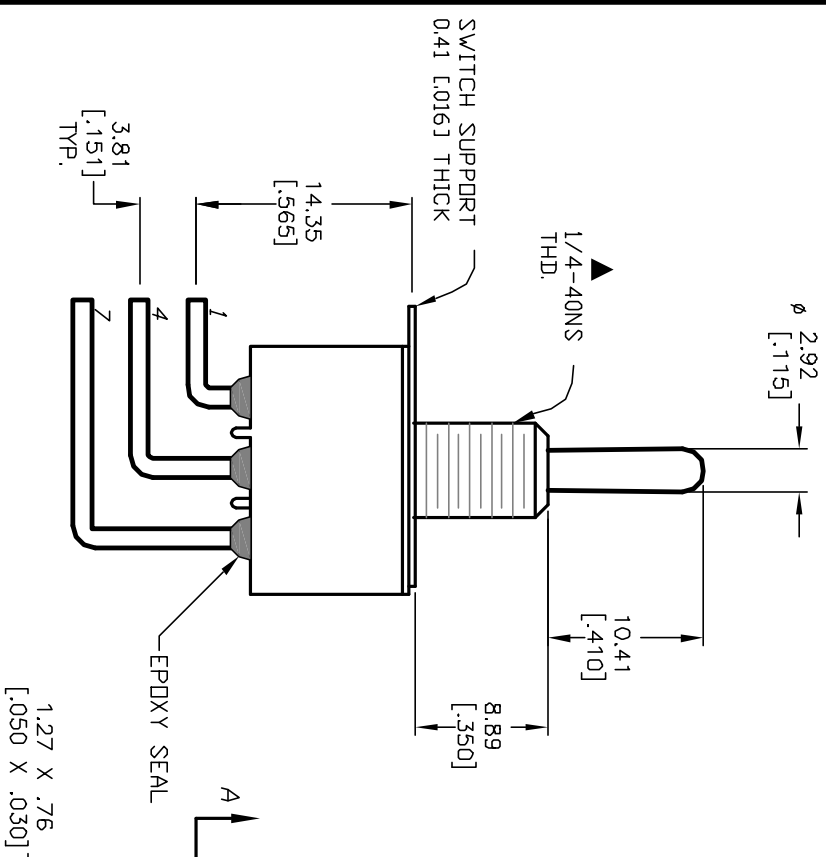

REV. A	12328	RELEASED	8/7/02	CJB
REV. ECN No.		DESCRIPTION	DATE	CHKD

TITLE		SCALE	DATE	DR	DWG	REV
100 3P-1 T1 B1 M6 Q E		2:1	--	--	T131014	A



THE INFORMATION CONTAINED IN THIS DOCUMENT IS PROPRIETARY TO E-SWITCH AND IS NOT TO BE COPIED OR TRANSMITTED