

SWITCH FUNCTION		
POS. 1	POS. 2	POS. 3
ON	OFF	ON
2-3	OPEN	2-1

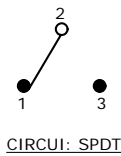

- NOTE:
1. ALL DIMENSIONS IN MM [INCH]
 2. GENERAL TOLERANCE: X.X=±0.4
X.XX=±0.25
 3. TERMINAL NUMBERS FOR REF ONLY
 - ▲ 4. PLATING MATERIAL: SILVER
 5. RATING: 2 AMPS @250VAC
5 AMPS @120VAC OR 28VDC
 6. ELECTRIC LIFE: 40,000 make-and-break cycles at full load.
 7. INSULATION RESISTANCE: 1,000 Mega-ohm min.
 8. DIELECTRIC STRENGTH: 1,000 V RMS @sea level.
 9. OPERATING TEMP.: -30°C to 85°C
 10. ▲ DENOTES CRITICAL PARAMETER.
 11. HARDWARE TO BE SUPPLIED BULK:
T100011-LOCK WASHER QTY-1
T100015-LOCK RING QTY-1
T100000-HEX NUT QTY-2

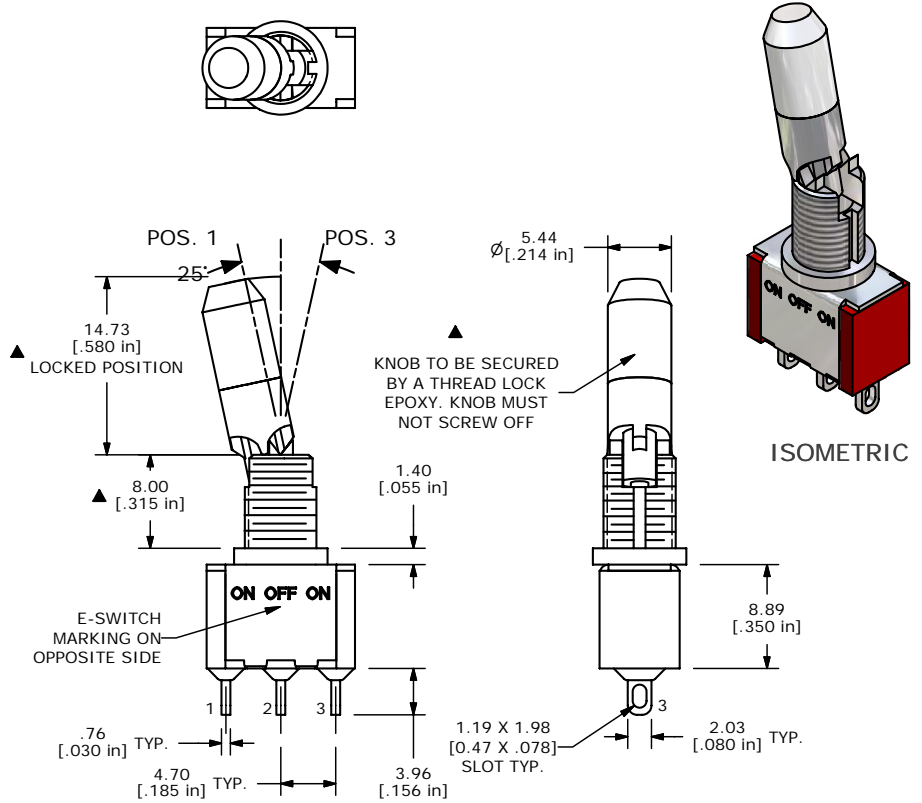

E-SWITCH®

TITLE 100SP3K2B25M1QE H				
SCALE 2:1	DATE 11/23/2005	DR PH	DWG ST116003	REV A

THE INFORMATION CONTAINED IN THIS DOCUMENT IS PROPRIETARY TO E-SWITCH AND IS NOT TO BE COPIED OR TRANSFERRED