

SWITCH FUNCTION		
POS. 1	POS. 2	POS. 3
ON	OFF	ON
2-3	OPEN	2-1

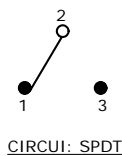

- NOTE:
- ALL DIMENSIONS IN MM [INCH]
 - GENERAL TOLERANCE: X.X=±0.4
X.XX=±0.25
 - TERMINAL NUMBERS FOR REF ONLY
 - ▲ PLATING MATERIAL: SILVER
 - RATING: 2 AMPS @250VAC
5 AMPS @120VAC OR 28VDC
 - ELECTRIC LIFE: 40,000 make-and-break cycles at full load.
 - INSULATION RESISTANCE: 1,000 Mega-ohm min.
 - DIELECTRIC STRENGTH: 1,000 V RMS @sea level.
 - OPERATING TEMP.: -30°C to 85°C
 - ▲ DENOTES CRITICAL PARAMETER.
 - HARDWARE TO BE SUPPLIED BULK:
T100011-LOCK WASHER QTY-1
T100015-LOCK RING QTY-1
T100000-HEX NUT QTY-2
 - 2002/95/EC (ROHS) COMPLIANT

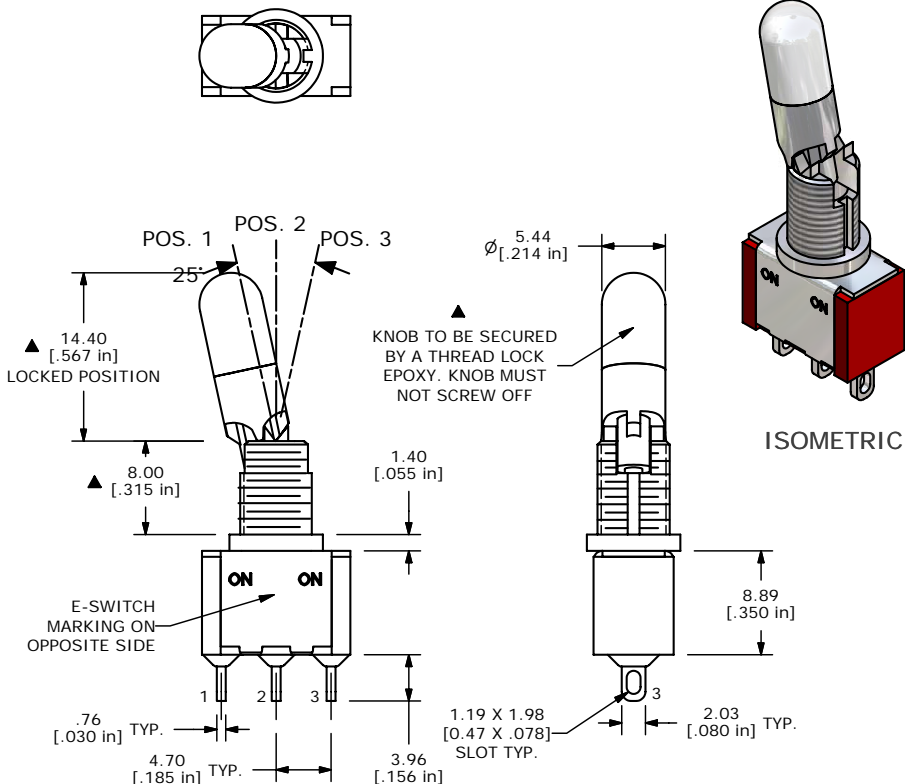

B	15786	ADD ROHS, EDIT ACTUATOR DIM	2/17/06	PH
A	15560	RELEASED FOR PRODUCTION	11/23/05	PH
REV	PCR NO	DESCRIPTION	DATE	BY

THE INFORMATION CONTAINED IN THIS DOCUMENT IS PROPRIETARY TO E-SWITCH AND IS NOT TO BE COPIED OR TRANSFERRED

E-SWITCH®				
TITLE 100SP3K1B25M1QEH				
SCALE	DATE	DR	DWG	REV
2:1	11/23/2005	PH	ST116001	B