

RECOMMENDED PCB LAYOUT

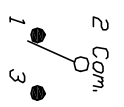

SPDT CIRCUIT CONTACT CONFIGURATION

SWITCH FUNCTION		
PDS. 1	PDS. 2	PDS. 3
<DN>	OFF	<DN>
2-3	OPEN	2-1

NOTES:

1. ALL DIMENSIONS IN MM [INCH]
2. GENERAL TOLERANCE: X.X=±0.4 X.XX=±0.25
3. TERMINAL NUMBERS FOR REF ONLY
4. RATING: 0.4VA @20V AC or DC max.
5. FIXED TERM. & MOVING CONTACT:
COPPER Alloy w/GOLD plate over Nickel plate.
6. ELECTRIC LIFE: 50,000 make-and-break cycles at full load.
7. INSULATION RESISTANCE: 1,000 Mega-ohm min.
8. DIELECTRIC STRENGTH: 1,000 V RMS @sea level.
9. OPERATING TEMP.: -30°C to +85°C

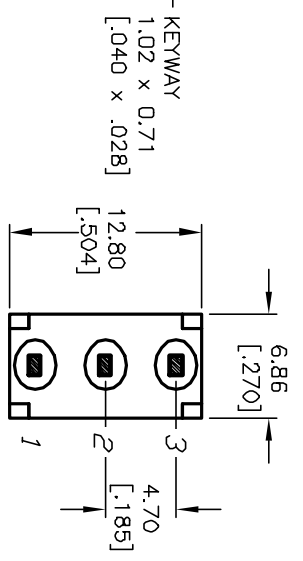
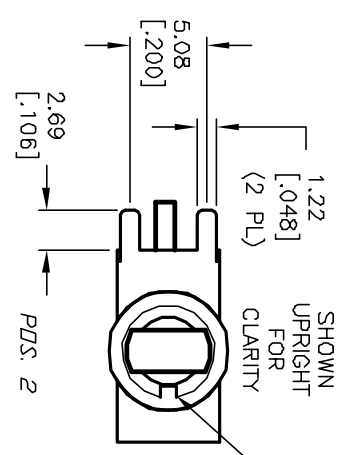

▲**T6 ACTUATOR W/ BUILT IN ANTI-ROTATION

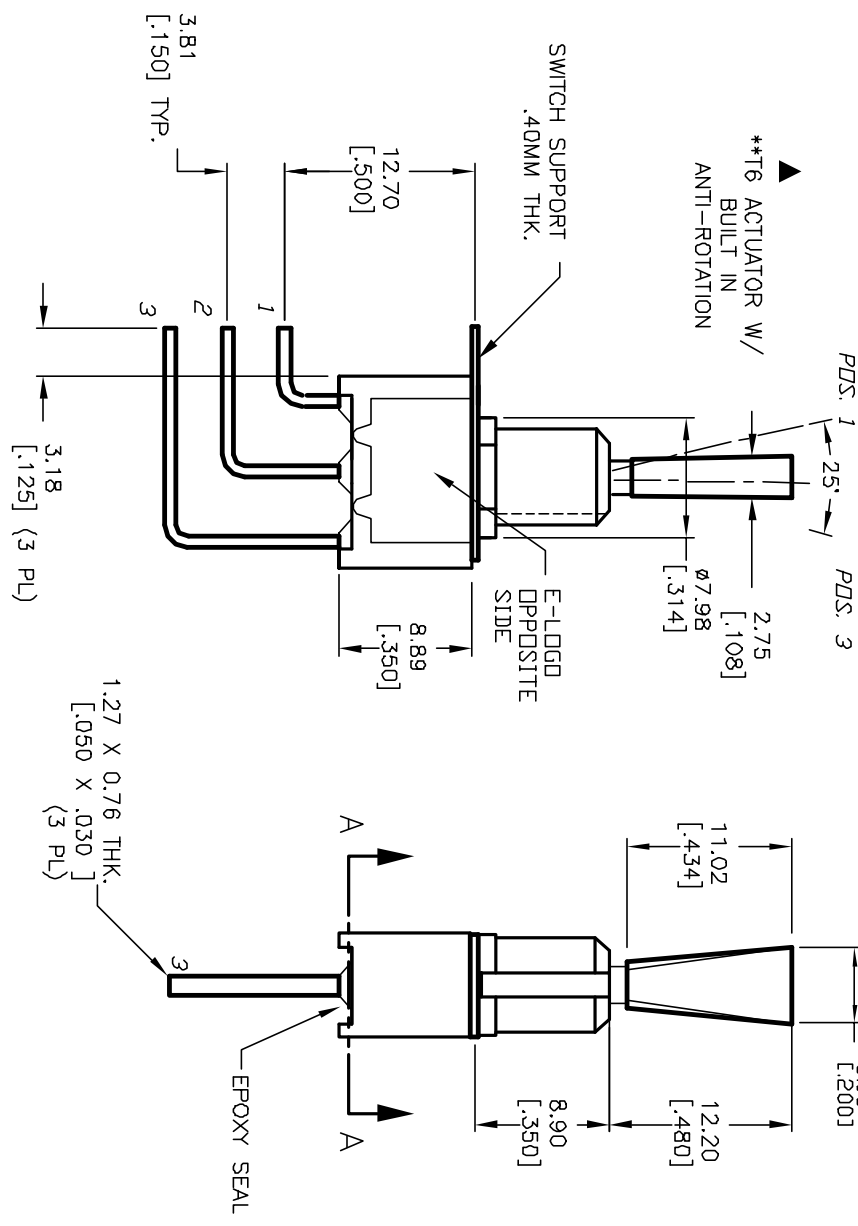

E-SWITCH®

REV.	ECN NO.	DESCRIPTION	DATE	CHKD
A	12018	RELEASED FOR PRODUCTION	5/2/02	CB

TITLE	SCALE	DATE	DR	DWG	REV
100 SP-4 T6 B12 M7 R E (GOLD CONTACTS)	2:1	5/2/02	CB	T114036	A