

PC MOUNTING

SWITCH FUNCTION		
POS. 1	POS. 2	POS. 3
ON	NONE	ON
2-3	N/A	2-1

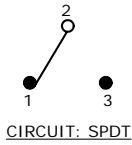

- NOTE:
- ALL DIMENSIONS IN MM [INCH]
 - GENERAL TOLERANCE: X.X=±0.4
X.XX=±0.25
 - TERMINAL NUMBERS FOR REF ONLY
 - ▲ PLATING MATERIAL: GOLD
 - RATING: 0.4 (VA) MAX. @20V MAX.
 - ELECTRIC LIFE: 30,000 MAKE-AND-BREAK CYCLES AT FULL LOAD.
 - INSULATION RESISTANCE: 1,000 MEGA-OHM MIN.
 - DIELECTRIC STRENGTH: 1,000 V RMS @SEA LEVEL.
 - OPERATING TEMP.: -30°C to 85°C
 - ▲ DENOTES CRITICAL PARAMETER.
 - HARDWARE TO BE SHIPPED BULK
T100000 - HEXNUT - QTY 2
T100011 - LOCKWASHER - QTY 1
T100015 - LOCKRING - QTY 1

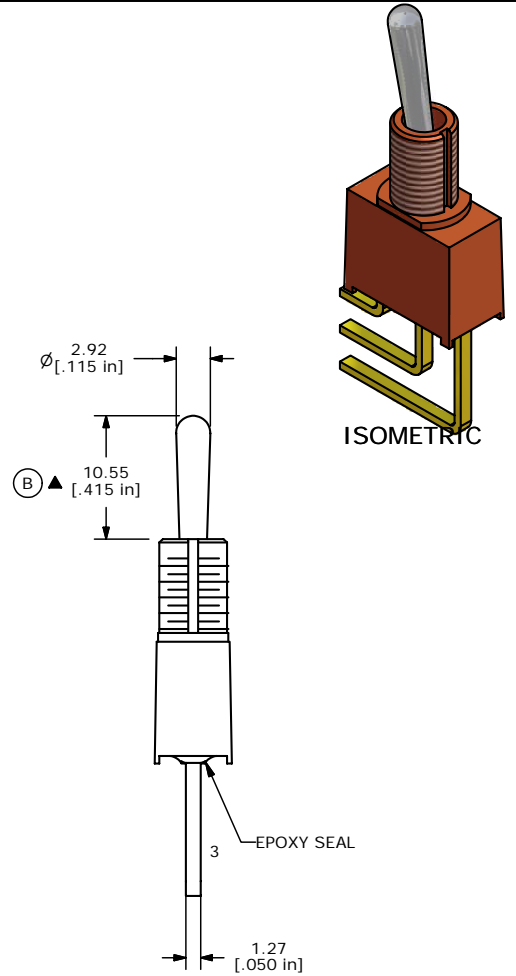
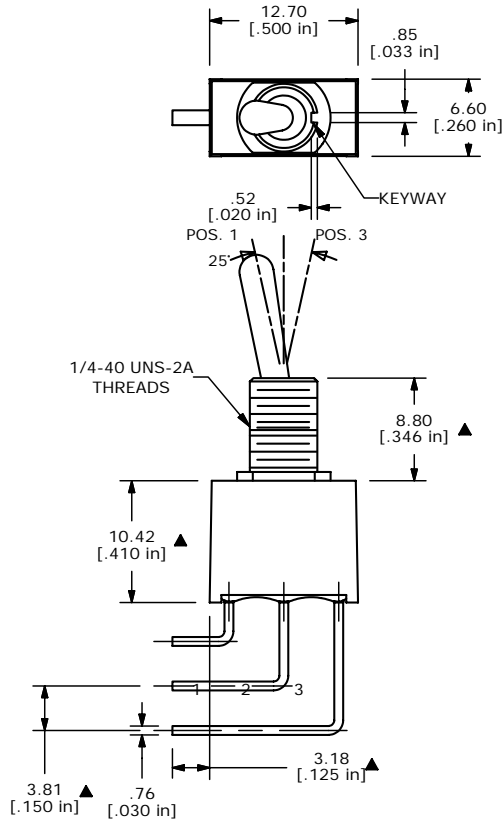

B	15429	REMOVED PC BRACKED, DIM FROM 12.7	10/21/05	PH
A	15239	RELEASED FOR PRODUCTION	9/6/05	PH
REV	PCR NO	DESCRIPTION	DATE	BY

THE INFORMATION CONTAINED IN THIS DOCUMENT IS PROPRIETARY TO E-SWITCH AND IS NOT TO BE COPIED OR TRANSFERRED

E-SWITCH®				
TITLE 100AWSP1T1B1M7REH				
SCALE	DATE	DR	DWG	REV
2:1	9/6/2005	PH	ST101036	B