

RECOMMENDED PCB LAYOUT

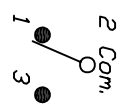

SPDT CIRCUIT CONTACT CONFIGURATION

SWITCH FUNCTION		
POS. 1	POS. 2	POS. 3
<DN>	OFF	<DN>
2-3	OPEN	2-1

() = Momentary

NOTES:

1. ALL DIMENSIONS IN MM [INCH]
2. GENERAL TOLERANCE: X.X=±0.4
X.XX=±0.25
3. TERMINAL NUMBERS FOR REF ONLY
4. RATING: 0.4VA @20V AC or DC max.
5. FIXED TERM. & MOVING CONTACT:
COPPER Alloy w/GOLD plate over
Nickel plate.
6. ELECTRIC LIFE: 40,000 make-and-break cycles
at full load.
7. INSULATION RESISTANCE: 1,000 Mega-ohm min.
8. DIELECTRIC STRENGTH: 1,000 V RMS @sed level.
9. OPERATING TEMP.: -30°C to +85°C

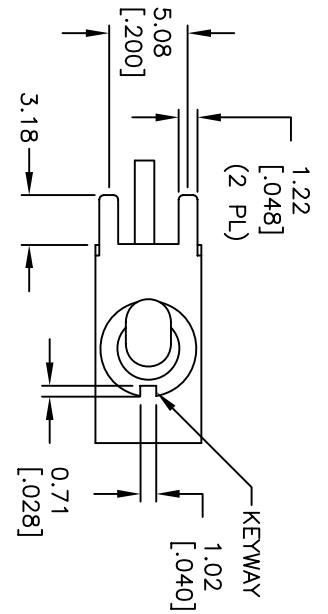

SECTION A-A

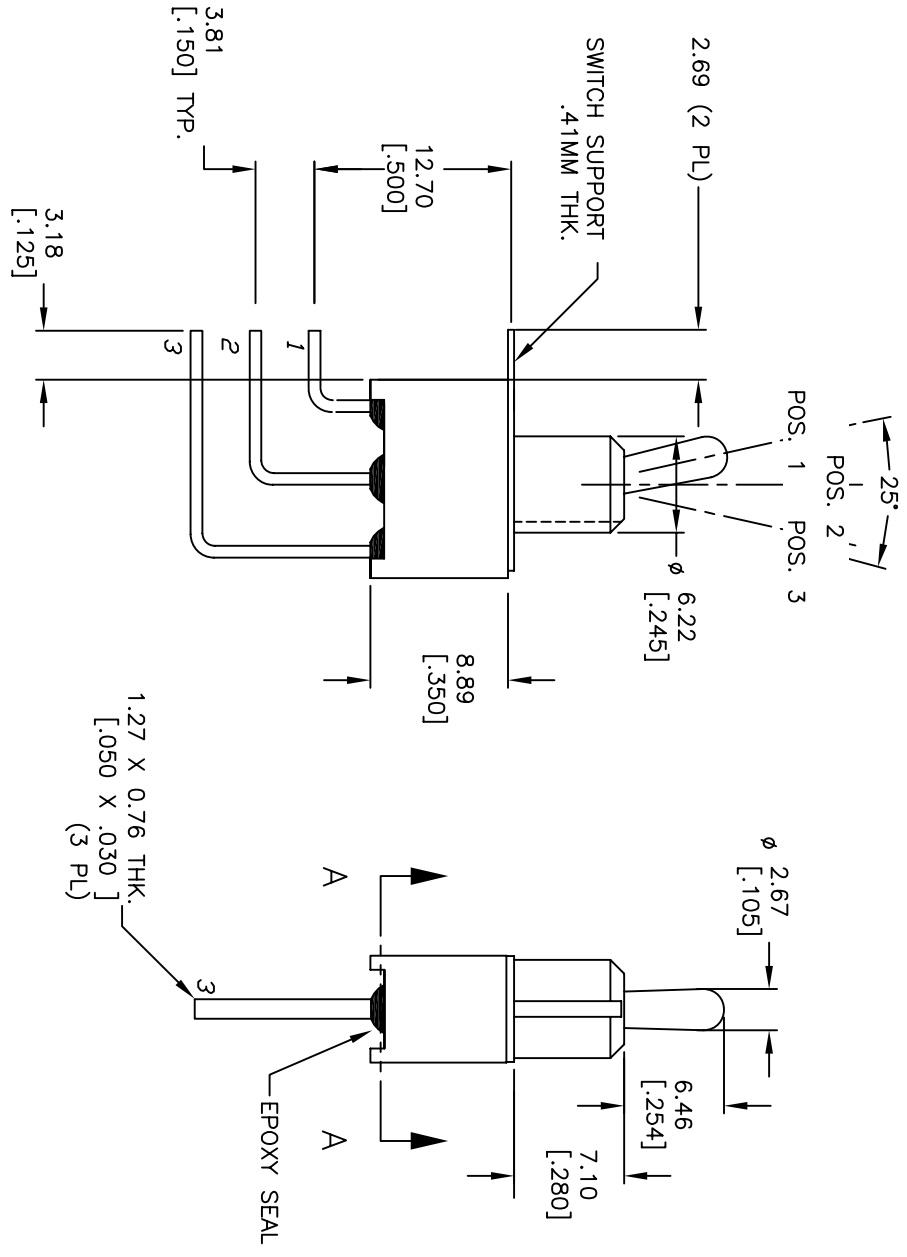
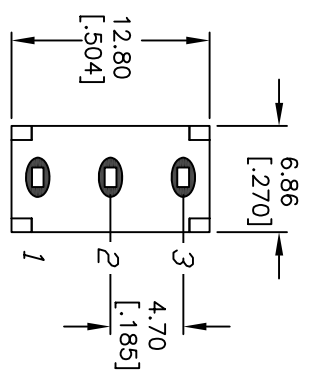

REV.	ECN No.	DESCRIPTION	DATE	CHKD
A	12547	RELEASED FOR PRODUCTION	11/8/02	CB
B	15100	UPDATED DIMENSIONS	7/26/05	RC

TITLE	SCALE	DATE	DR	DWG	REV
100 SP4 T2 B4 M7 RE	2:1	6/1/01	CB	T114039	B

