

SHEET 1 OF 1

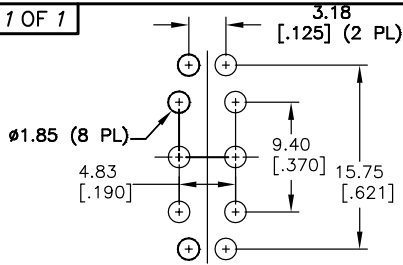

RECOMMENDED PCB LAYOUT

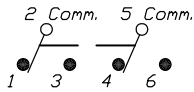

DPDT CIRCUIT

CONTACT CONFIGURATION

SWITCH FUNCTION		
PDS. 1	PDS. 2	PDS. 3
ON	NONE	ON
2-3, 5-6	OPEN	2-1, 5-4

NOTES:

1. ALL DIMENSIONS IN MM
2. GENERAL TOLERANCE: 0.0±0.4
0.00±0.25
3. TERMINAL NUMBERS FOR REF ONLY
4. RATING: 5 AMPS @ 120VAC OR 28VDC;
2 AMPS @ 250VAC
5. ELECTRIC LIFE: 50,000 make-and-break cycles at full load.
6. INSULATION RESISTANCE: 1,000 Mega-ohm min.
7. DIELECTRIC STRENGTH: 1,000 V RMS @sea level.
8. OPERATING TEMP.: -30°C to 85°C
9. ▲ DENOTES CRITICAL PARAMETER.

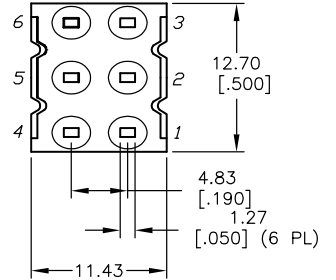
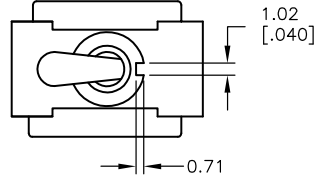

SECTION A-A
BRACKET NOT SHOWN

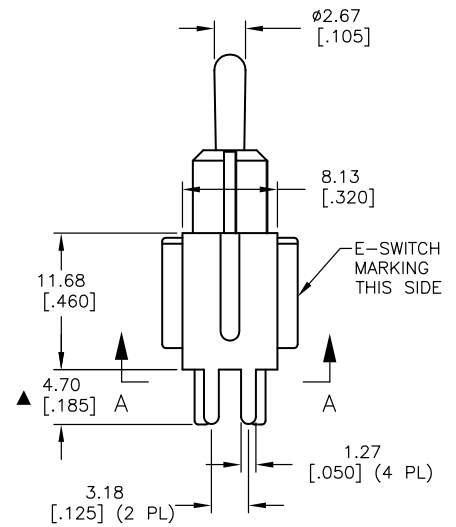
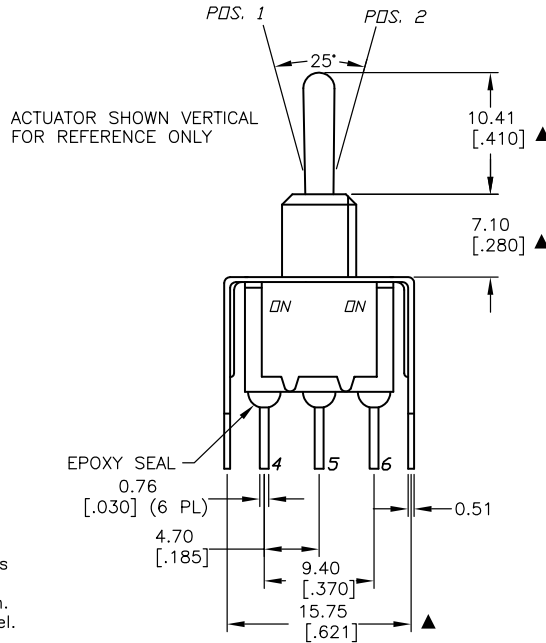

E-SWITCH®

TITLE				
100DP1T1B4VS2QE				
SCALE	DATE	DR	DWG	REV
2:1	8/22/03	AR	T121052	A

THE INFORMATION CONTAINED IN THIS DOCUMENT IS PROPRIETARY TO E-SWITCH AND IS NOT TO BE COPIED OR TRANSFERRED

A	13394	RELEASED FOR PRODUCTION	8/22/03	AR
REV.	ECN No.	DESCRIPTION	DATE	CHKD