

RECOMMENDED PCB LAYOUT

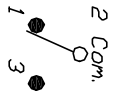

SPDT CIRCUIT CONTACT CONFIGURATION

SWITCH FUNCTION		
POS. 1	POS. 2	POS. 3
DN	N/D/N/E	DN
2-3	DPEN	2-1

NOTES:

1. ALL DIMENSIONS IN MM [INCH]
2. GENERAL TOLERANCE: X.X=±0.4 X.XX=±0.25
3. TERM. NOS. FOR REF. ONLY
4. RATING: 0.4(VA) @20V AC or DC max.
5. FIXED TERMINAL/MOVING CONTACT:  
Copper Alloy W/GOLD plate over  
Nickel plate.
6. ELECTRICAL LIFE: 50,000 make-and-break cycles at full load.
7. INSULATION RESISTANCE: 1,000M ohm min.
8. DIELECTRIC STRENGTH: 1000V RMS @sed level
9. OPERATING TEMP.: -30°C to +85°C

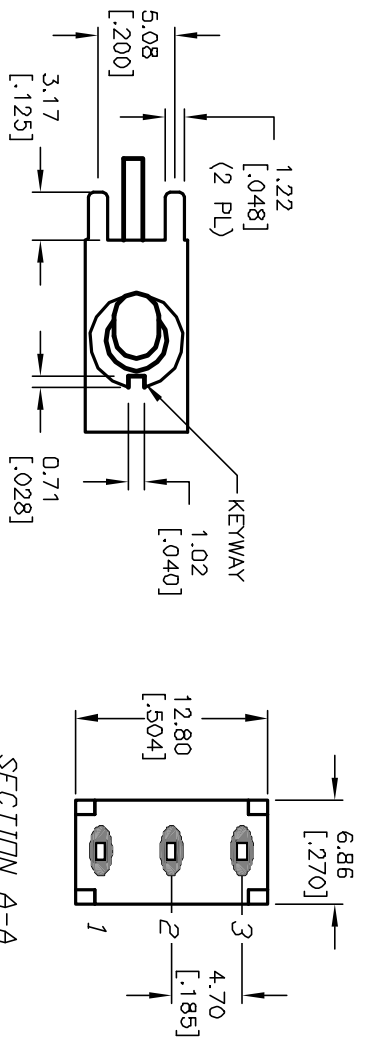

SECTION A-A

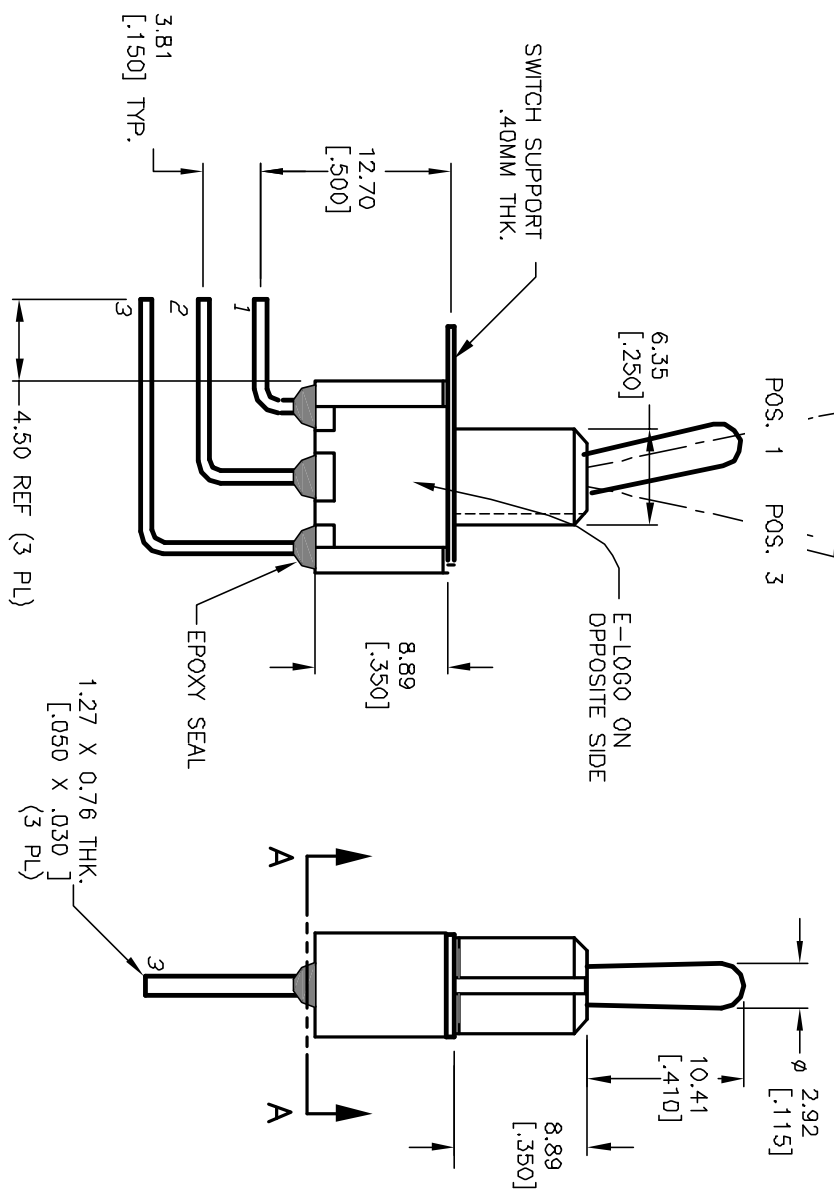

REV.	ECN NO.	DESCRIPTION	DATE	CHKD
A	--	RELEASED	10/10/02	CB

TITLE	SCALE	DATE	DR	DWG	REV
100 SP-1 T1 B2 M7 R E (GOLD CONTACTS)	2:1	--	--	T111076	A

