

RECOMMENDED PCB LAYOUT

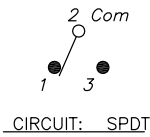

SWITCH FUNCTION		
POS. 1	POS. 2	POS. 3
ON	OFF	ON
2-3	OPEN	2-1

NOTES:

1. ALL DIMENSIONS IN MM [INCH]
2. GENERAL TOLERANCE: X.X=±0.4
X.XX=±0.25
3. TERMINAL NUMBERS FOR REF ONLY
- ▲ 4. RATING: 5 AMPS W/RESISTANT LOAD @ 120VAC OR 28VDC
2 AMPS W/RESISTANT LOAD @ 250VAC
5. FIXED TERM. & MOVING CONTACT:
SILVER PLATED COPPER ALLOY
6. ELECTRIC LIFE: 40,000 MAKE-AND-BREAK CYCLES
AT FULL LOAD.
7. INSULATION RESISTANCE: 1,000 MEGA-OHM MIN.
8. DIELECTRIC STRENGTH: 1,000 V RMS @SEA LEVEL.
9. OPERATING TEMP.: -30°C to 85°C
10. ▲ DENOTES CRITICAL PARAMETER.

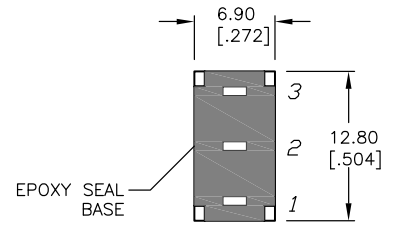
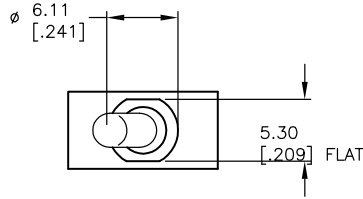

BOTTOM VIEW

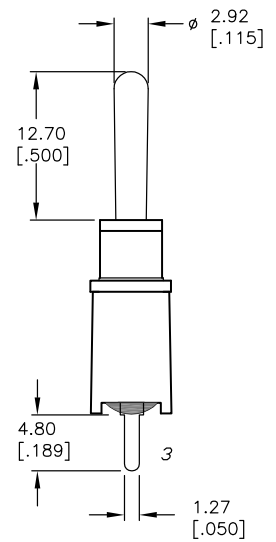
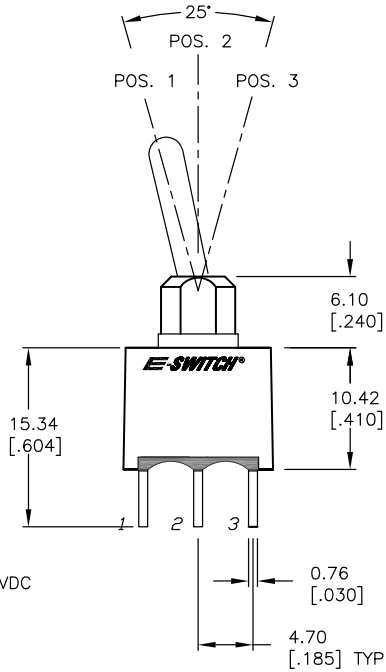

E-SWITCH®

TITLE				
100AWSP3T1B4M2QE				
SCALE	DATE	DR	DWG	REV
2:1	12/4/03	AR	T103006	A

THE INFORMATION CONTAINED IN THIS DOCUMENT IS PROPRIETARY TO E-SWITCH AND IS NOT TO BE COPIED OR TRANSFERRED