

PANEL MOUNTING

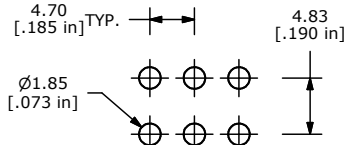

P.C. MOUNTING

SWITCH FUNCTION		
POS. 1	POS. 2	POS. 3
ON	OFF	ON
2-3, 5-6	OPEN	2-1, 5-4



CIRCUIT: DPDT

NOTE:

1. ALL DIMENSIONS IN MM [INCH]
2. GENERAL TOLERANCE: X.X=±0.4  
X.XX=±0.25
3. TERMINAL NUMBERS FOR REF ONLY
4. CONTACT MATERIAL: GOLD
- ▲5. RATING: 0.4VA MAX. @ 20 VAC OR VDC MAX.
6. ELECTRIC LIFE: 40,000 MAKE-AND-BREAK CYCLES AT FULL LOAD.
7. INSULATION RESISTANCE: 1,000 MEGA-OHM MIN.
8. DIELECTRIC STRENGTH: 1,000 V RMS @SEA LEVEL.
9. OPERATING TEMP.: -30°C to 85°C
10. ▲ DENOTES CRITICAL PARAMETER.
11. 2002/95/EC (ROHS) COMPLIANT
12. HARDWARE TO BE SHIPPED BULK  
T100000 - HEXNUT - QTY 2  
T100011 - LOCKWASHER - QTY 1  
T100002 - LOCKRING - QTY 1

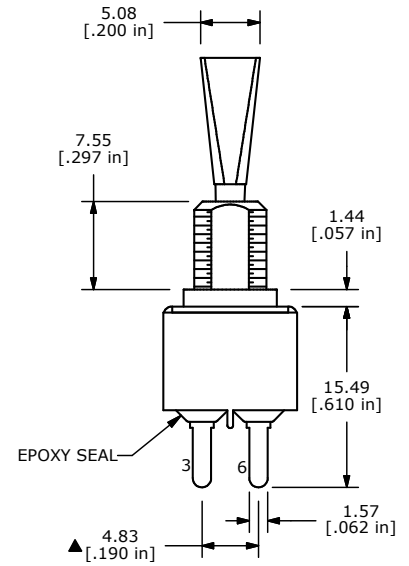
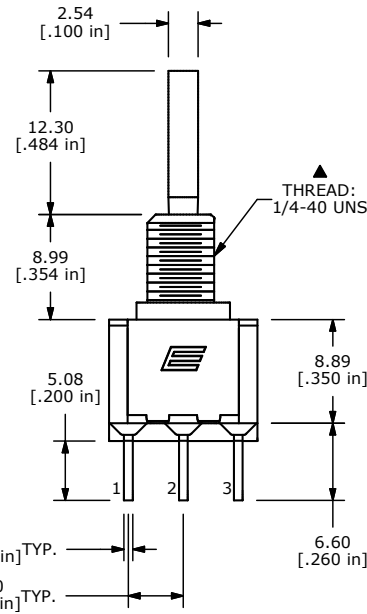
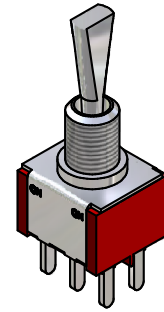
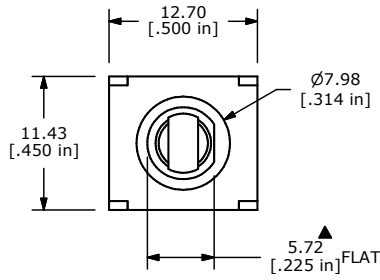

TITLE 100DP3T6B15M3REH

A	17779	RELEASED FOR PRODUCTION	10/17/07	BF
REV	PCR NO	DESCRIPTION	DATE	BY

THE INFORMATION CONTAINED IN THIS DOCUMENT IS PROPRIETARY TO E-SWITCH AND IS NOT TO BE COPIED OR TRANSFERRED

SCALE 2:1	DATE 10/17/2007	DR BF	DWG ST121086	REV A
-----------	-----------------	-------	--------------	-------