

CIRCUIT: SPDT

SWITCH FUNCTION		
PDS. 1	PDS. 2	PDS. 3
DN	DN	DN
DN	NONE	DN
2-3	OPEN	2-1

NOTES:

1. ALL DIMENSIONS IN MM. [INCH]
2. GENERAL TOLERANCE: X.X=±0.4
X.XX=±0.25
3. TERM. NOS. FOR REF. ONLY
4. RATING: 0.4(VA) @20V AC or DC max.
5. FIXED TERMINAL/MOVING CONTACT:
Copper Alloy W/GOLD plate over Nickel plate.
6. ELECTRICAL LIFE: 50,000 make-and-break cycles at full load.
7. INSULATION RESISTANCE: 1,000M ohm min.
8. DIELECTRIC STRENGTH: 1000V RMS @sea level
9. OPERATING TEMP.: -30°C to +85°C
10. 2002/95/EC (ROHS) COMPLIANT
11. HARDWARE TO BE SUPPLIED BULK:
T100011-LOCK WASHER QTY-1
T100015-LOCK RING QTY-1
T100000-HEX NUT QTY-2

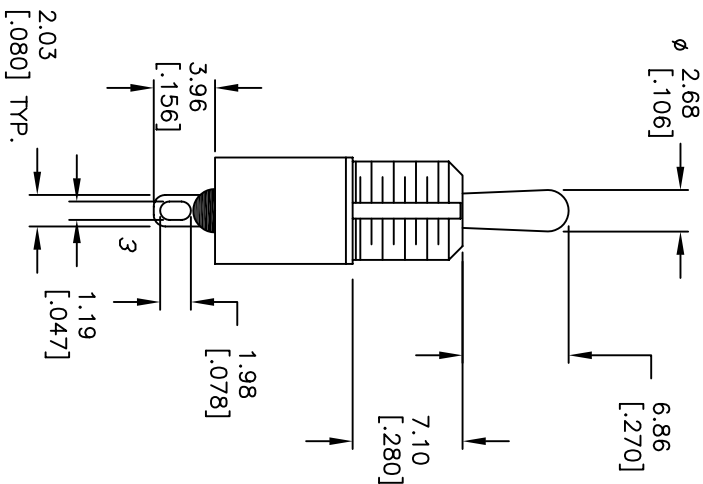
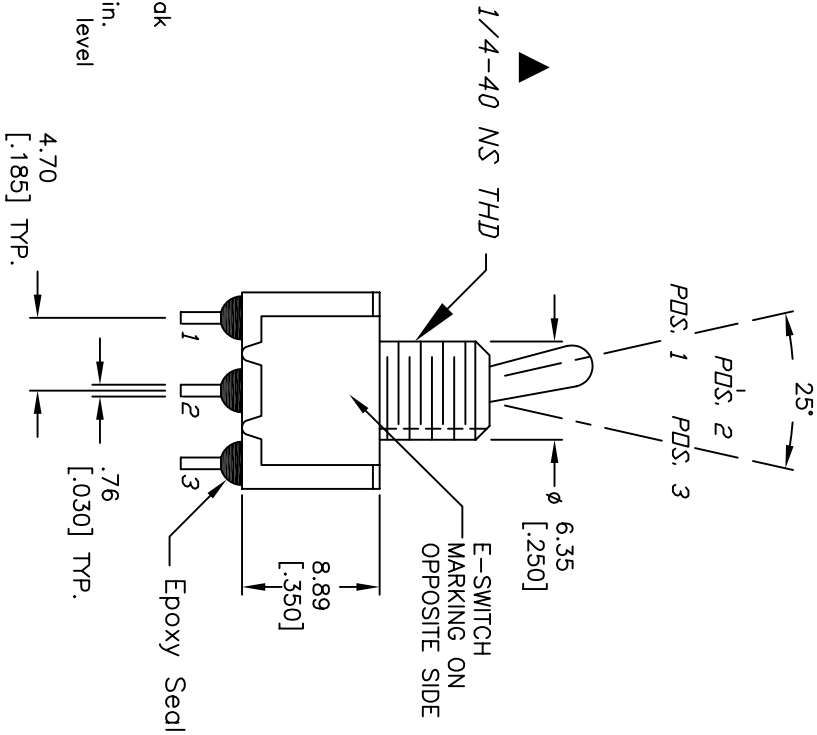
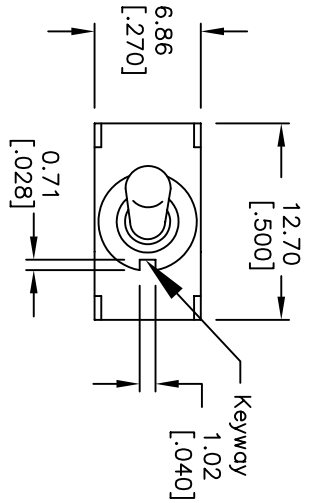

E-SWITCH®

TITLE: 100 SP-1 T2 B3 M1 R EH (GOLD CONTACTS)

SCALE: 2:1 DATE: 11/10/05 DR: PH DWG: ST111075 REV: A

THE INFORMATION CONTAINED IN THIS DOCUMENT IS PROPRIETARY TO E-SWITCH AND IS NOT TO BE COPIED OR TRANSFERRED

REV. A ECN No. 15519 RELEASE 11/10/05 PH

DESCRIPTION DATE CHKD