

SWITCH FUNCTION		
POS. 1	POS. 2	POS. 3
ON	NONE	ON
2-3	N/A	2-1

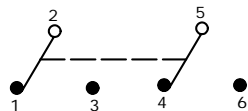

CIRCUIT: DPDT

NOTE:

1. ALL DIMENSIONS IN MM [INCH]
2. GENERAL TOLERANCE: X.X=±0.4  
X.XX=±0.25
3. TERMINAL NUMBERS FOR REF ONLY
- ▲ 4. PLATING MATERIAL: SILVER
5. RATING: 5AMPS W/RESISTIVE LOAD @ 120VAC OR 28VDC  
2 AMPS W/ RESISTIVE LOAD @ 250VAC
6. ELECTRIC LIFE: 40,000 make-and-break cycles at full load.
7. INSULATION RESISTANCE: 1,000 Mega-ohm min.
8. DIELECTRIC STRENGTH: 1,000 V RMS @sea level.
9. OPERATING TEMP.: -30°C to 85°C
10. ▲ DENOTES CRITICAL PARAMETER.
11. 2002/95/EC (ROHS) COMPLIANT
12. HARDWARE TO BE SHIPPED BULK  
T100011 - LOCK WASHER, QTY 1  
T100002 - LOCK RING, QTY 1  
T100000 - HEX NUT, QTY 2

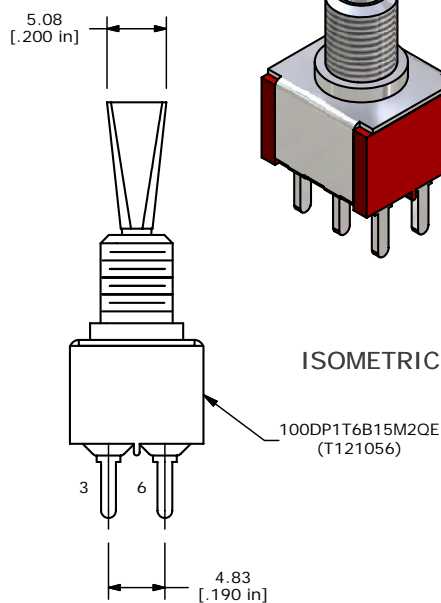
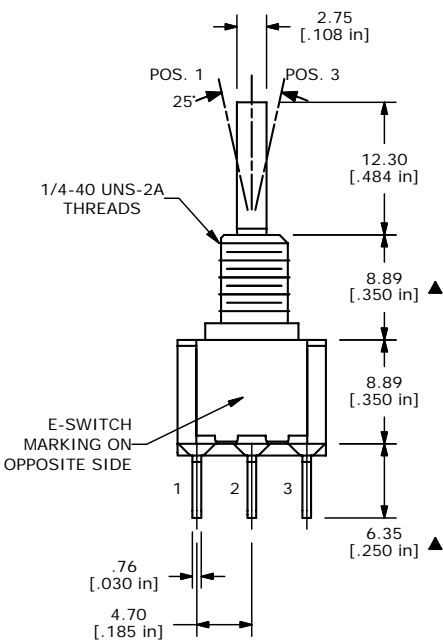
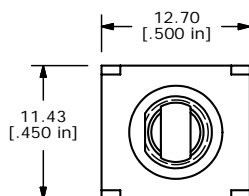

**E-SWITCH®**

TITLE 100DP1T6B15M2QEH

A	16174	NEW PART RELEASE	6/22/06	CT
REV	PCR NO	DESCRIPTION	DATE	BY

THE INFORMATION CONTAINED IN THIS DOCUMENT IS PROPRIETARY TO E-SWITCH AND IS NOT TO BE COPIED OR TRANSFERRED

SCALE 2:1	DATE 6/22/2006	DR CT	DWG ST121056	REV A
-----------	----------------	-------	--------------	-------