

CONTACT CONFIGURATION

SWITCH FUNCTION			
POS. 1	POS. 2	POS. 3	
DN	NONE	DN	
2-3	DOPEN	2-1	

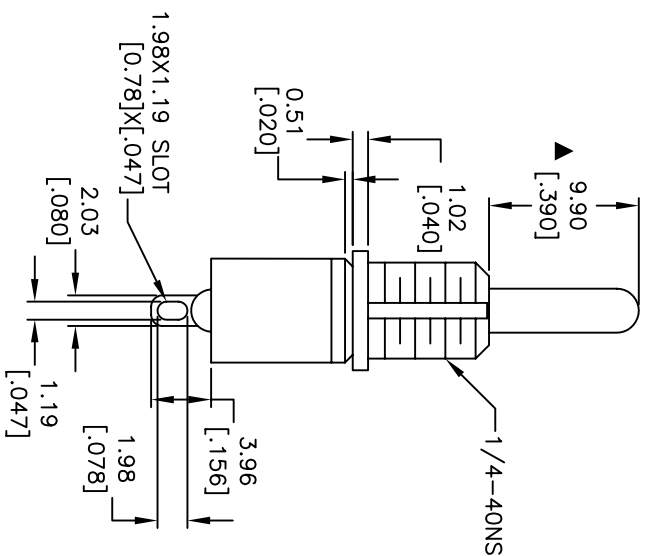
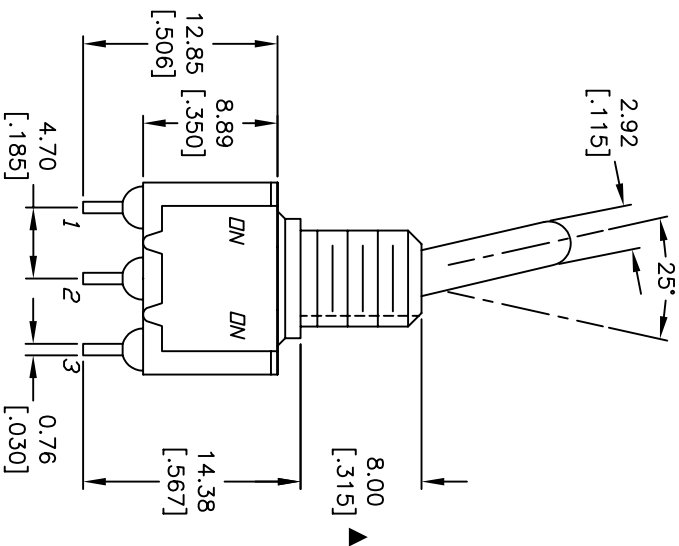
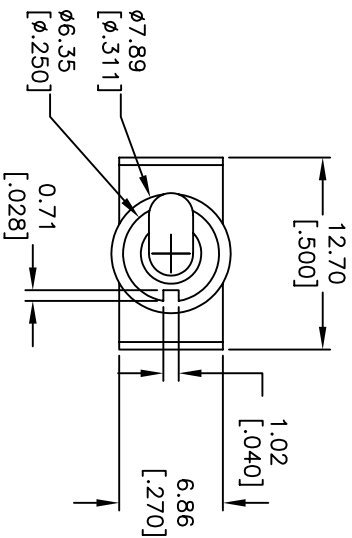

NOTES:

1. ALL DIMENSIONS IN MM [INCH]
2. GENERAL TOLERANCE: X.X=±0.4  
X.XX=±0.25
3. TERM. NOS. FOR REF. ONLY
4. RATING: 5A @120VAC OR 28VDC  
2A @250VAC
5. FIXED TERM. & MOVING CONTACT:  
Copper ALLOY W/Silver plate.
6. ELECTRICAL LIFE: 50,000 make-and-break  
cycles at full load.
7. INSULATION RESISTANCE: 1,000M ohm min.
8. DIELECTRIC STRENGTH: 1000V RMS @sed level
9. OPERATING TEMP.: -30°C to 85°C
10. ▲ DENOTES CRITICAL PARAMETER.
11. 2002/95/EC (ROHS) COMPLIANT

B	15500	ADD ROHS NOTE	11/4/05	PH
A	13302	RELEASE	7/18/03	AR
REV.	ECN No.	DESCRIPTION	DATE	CHKD

THE INFORMATION CONTAINED IN THIS DOCUMENT IS PROPRIETARY TO E-SWITCH AND IS NOT TO BE COPIED OR TRANSFERRED

TITLE		DATE		DR		DWG		REV	
100 SP-1 T1 B6 M1 Q E		7/18/03		AR		T111002		B	
SCALE		DATE		DR		DWG		REV	
2:1		7/18/03		AR		T111002		B	

**E-SWITCH®**