

SWITCH FUNCTION		
POS. 1	POS. 2	POS. 3
ON	NONE	ON
2-3, 5-6, 8-9, 11-12	OPEN	2-1, 5-4, 8-7, 11-10

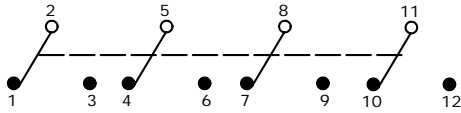
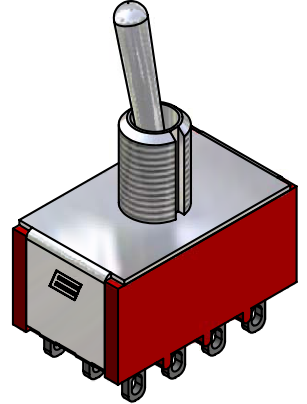
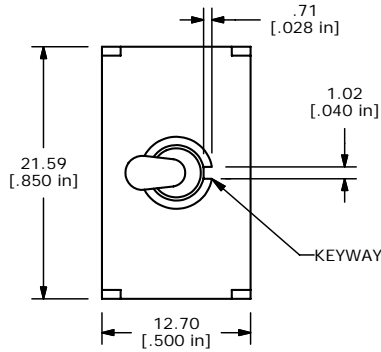

CIRCUI: 4PDT

NOTE:

1. ALL DIMENSIONS IN MM [INCH]
2. GENERAL TOLERANCE: X.X=±0.4  
X.XX=±0.25
3. TERMINAL NUMBERS FOR REF ONLY
4. PLATING MATERIAL: SILVER
- ▲5. RATING: 5A @ 120VAC OR 28VDC  
2A @ 250VAC W/ RESISTIVE LOADS
6. ELECTRIC LIFE: 50,000 MAKE-AND-BREAK CYCLES AT FULL LOAD.
7. INSULATION RESISTANCE: 1,000 MEGA-OHM MIN.
8. DIELECTRIC STRENGTH: 1,000 V RMS @SEA LEVEL.
9. OPERATING TEMP.: -30°C to 85°C
10. ▲ DENOTES CRITICAL PARAMETER.
- ▲11. HARDWARE TO BE SHIPPED BULK  
T100000 - HEXNUT - QTY 2  
T100011 - LOCKWASHER - QTY 1  
T100015 - LOCKRING - QTY 1

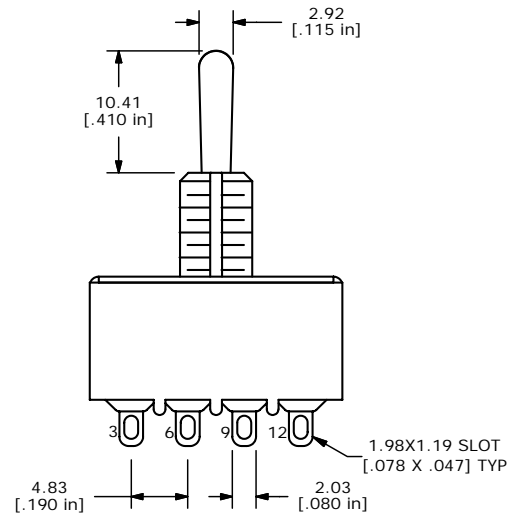
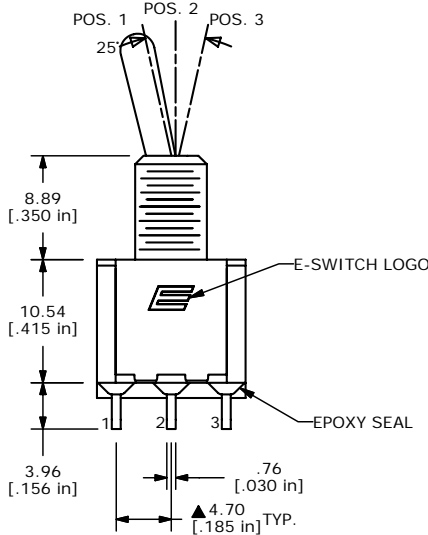

TITLE 1004P1T1B1M1QEH

A	17489	RELEASED FOR PRODUCTION	7/20/07	BF
REV	PCR NO	DESCRIPTION	DATE	BY

THE INFORMATION CONTAINED IN THIS DOCUMENT IS PROPRIETARY TO E-SWITCH AND IS NOT TO BE COPIED OR TRANSFERRED

SCALE 2:1	DATE 7/20/2007	DR BF	DWG ST141003	REV A
-----------	----------------	-------	--------------	-------