

RECOMMENDED PCB LAYOUT

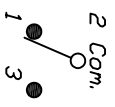

SPDT CIRCUIT CONTACT CONFIGURATION

SWITCH FUNCTION		
POS. 1	POS. 2	POS. 3
DN	DIFF	(DN)
2-3	OPEN	2-1

NOTES:
 1. ALL DIMENSIONS IN MM
 2. GENERAL TOLERANCE: X.X=±0.4
 X.XX=±0.25
 3. TERMINAL NUMBERS FOR REF ONLY
 4. RATING: 0.4(VA) Max. @20V (AC or DC)
 5. FIXED TERM. & MOVING CONTACT: Cu Alloy w/Gold plate over Ni plate.
 6. ELECTRIC LIFE: 40,000 make-and-break cycles at full load.
 7. INSULATION RESISTANCE: 1,000 Mega-ohm min.
 8. DIELECTRIC STRENGTH: 1,000 V RMS @sea level.
 9. OPERATING TEMP.: -30°C to 85°C

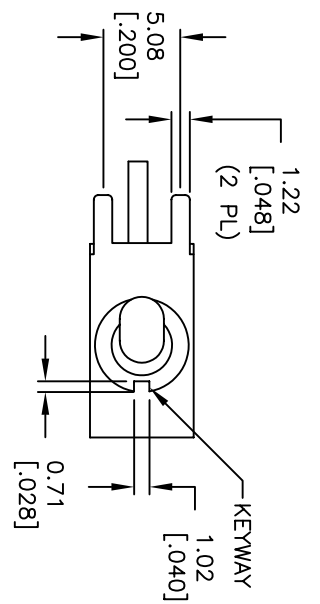

SECTION A-A

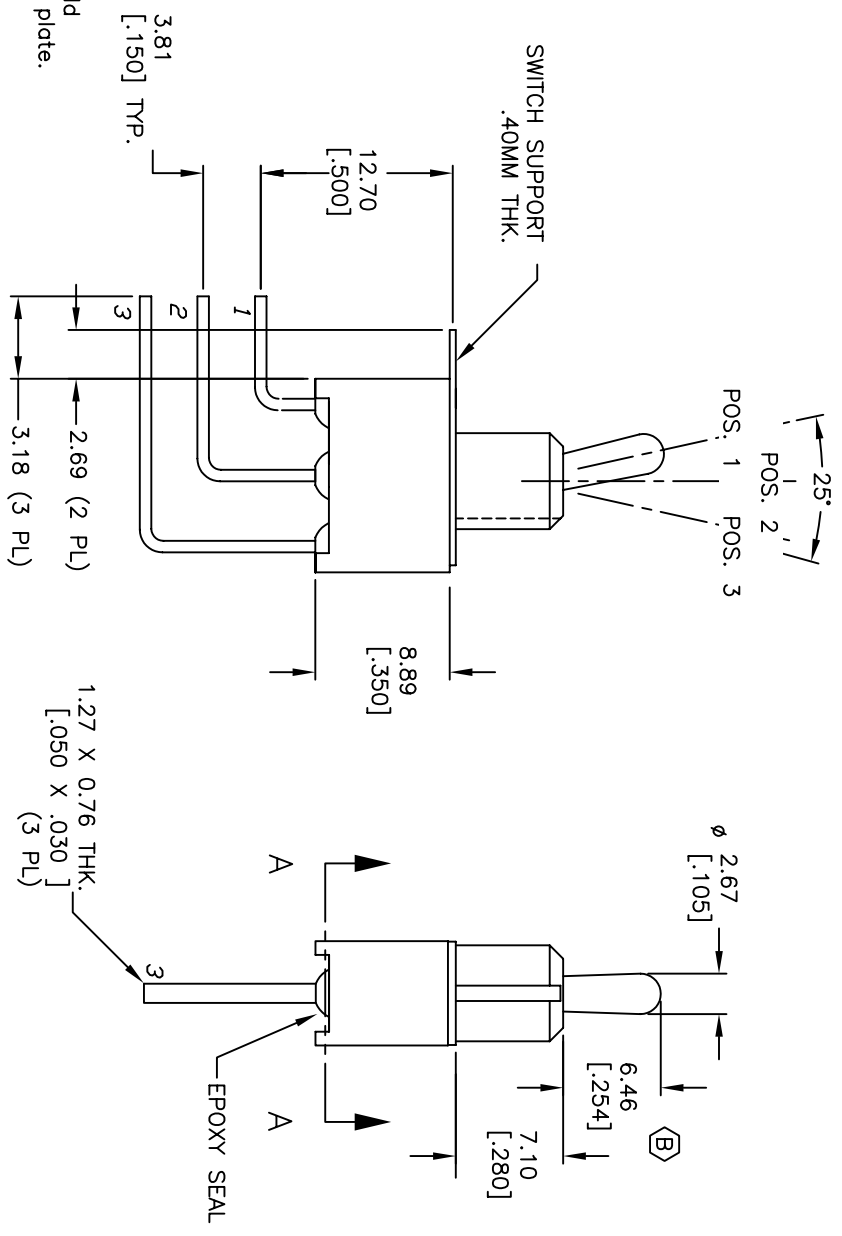
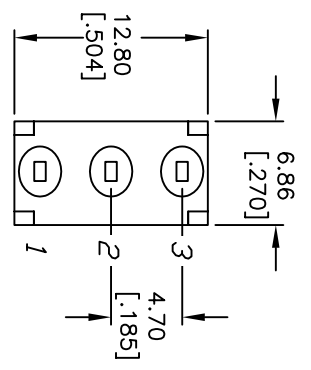

E-SWITCH®

REV.	ECN No.	DESCRIPTION	DATE	CHKD
C	15393	EDIT TERM LENGTH, NOTE 6	10/17/05	PH
B	14044	ACTUATOR HEIGHT	5/27/04	AR
A	11523	RELEASED FOR PRODUCTION	6/01/01	CB

TITLE	SCALE	DATE	DR	DWG	REV
100 SP-5 T2 B4 M7 R E	2:1	6/1/01	CB	T115016	C