

RECOMMENDED PCB LAYOUT

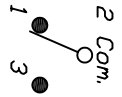

SPDT CIRCUIT CONTACT CONFIGURATION

SWITCH FUNCTION		
POS. 1	POS. 2	POS. 3
DN	NONE	DN
2-3	N/A	2-1

NOTES:

1. ALL DIMENSIONS IN MM [INCH]
2. GENERAL TOLERANCE: X.X=±0.4 X:XX=±0.25
3. TERMINAL NUMBERS FOR REF ONLY
4. RATING: 0.4VA @20V AC or DC max.
5. FIXED TERM. & MOVING CONTACT: COPPER Alloy w/GOLD plate over Nickel plate.
6. ELECTRIC LIFE: 50,000 make-and-break cycles at full load.
7. INSULATION RESISTANCE: 1,000 Mega-ohm min.
8. DIELECTRIC STRENGTH: 1,000 V RMS @sea level.
9. OPERATING TEMP.: -30°C to +85°C
10. 2002/95/EC (ROHS) COMPLIANT

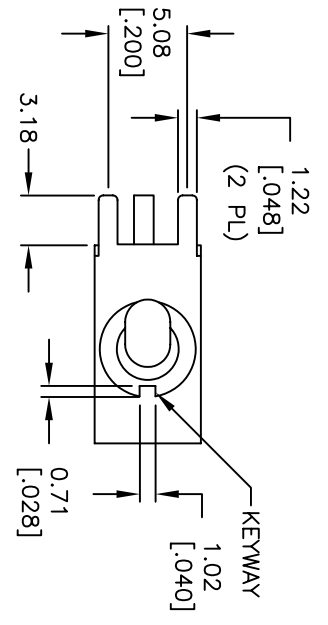

SECTION A-A

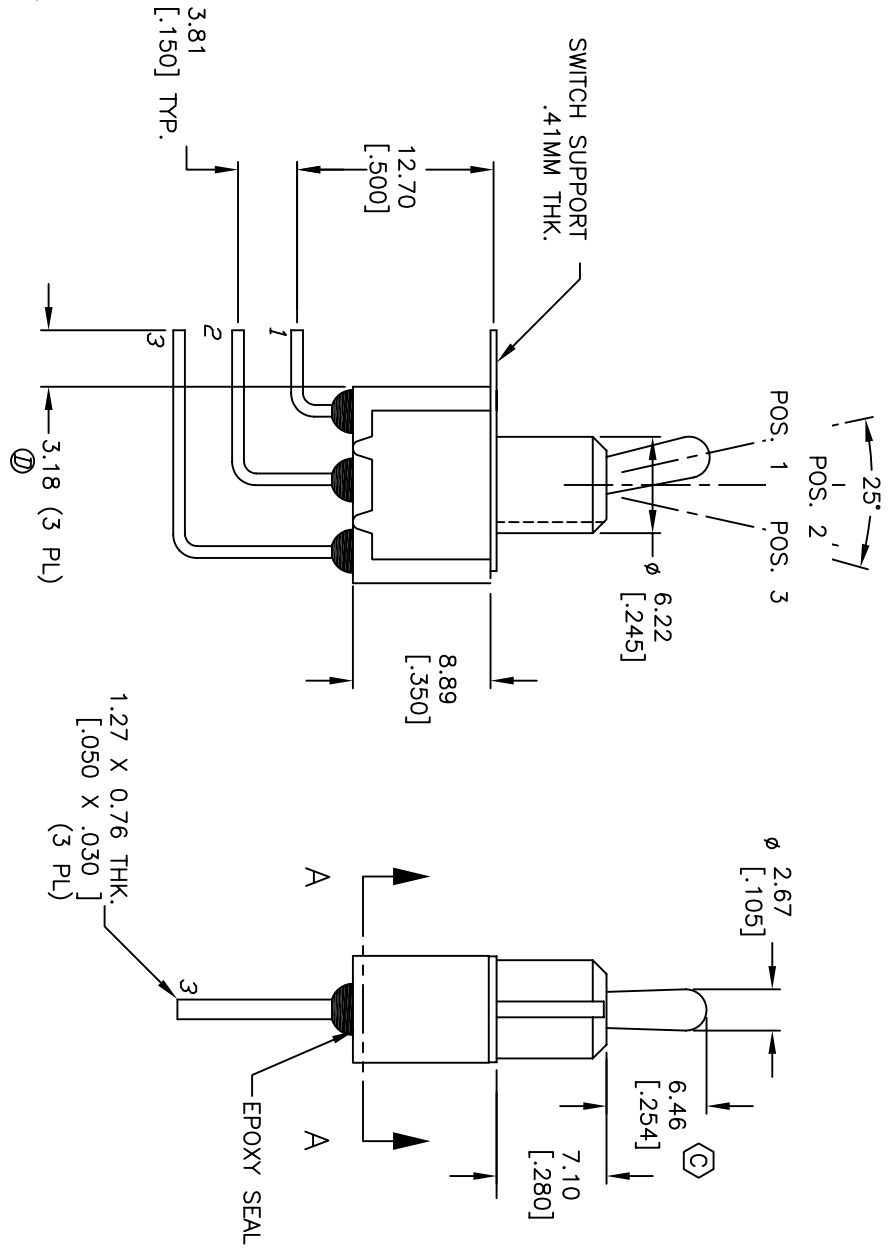
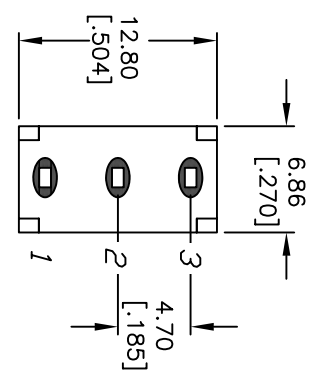

REV.	ECN No.	DESCRIPTION	DATE	CHKD
E	15789	EDIT TOP VIEW, ADD ROHS	2/17/06	PH
D	15200	CHANGES NOTED WITH Ⓞ	8/24/05	PH
C	14044	ACTUATOR HEIGHT	5/27/04	AR
B	12547	REVISED AND REDRAWN	12/2/02	CB

TITLE		SCALE	DATE	DR	DWG	REV
100 SP-1 T2 B4 M7 RE (GOLD CONTACTS)		2:1	--	--	T110003	E

