

CIRCUIT: DPDT

SWITCH FUNCTION		
POS. 1	POS. 2	POS. 3
DN	NONE	DN
2-3,5-6	DPEN	2-1,5-4

NOTES:

1. ALL DIMENSIONS IN MM [INCH]
2. GENERAL TOLERANCE: X.X=±0.4
X.XX=±0.25
3. TERM. NOS. FOR REF. ONLY
4. RATING: 5A @120V AC, or 28VDC
2A @250V AC
5. MATERIALS: FIXED TERM. &MOVING CONTACT:
Copper Alloy w/Silver plate
6. ELECTRICAL LIFE: 50,000 make-and-break
cycles at full load.
7. INSULATION RESISTANCE: 1,000M ohm min.
8. DIELECTRIC STRENGTH: 1000V RMS @sed level
9. OPERATING TEMP.: -30°C to 85°C
10. 2002/95/EC (ROHS) COMPLIANT
12. HARDWARE TO BE SUPPLIED BULK:
T100011-LOCK WASHER QTY-1
T100015-LOCK RING QTY-1
T100000-HEX NUT QTY-1

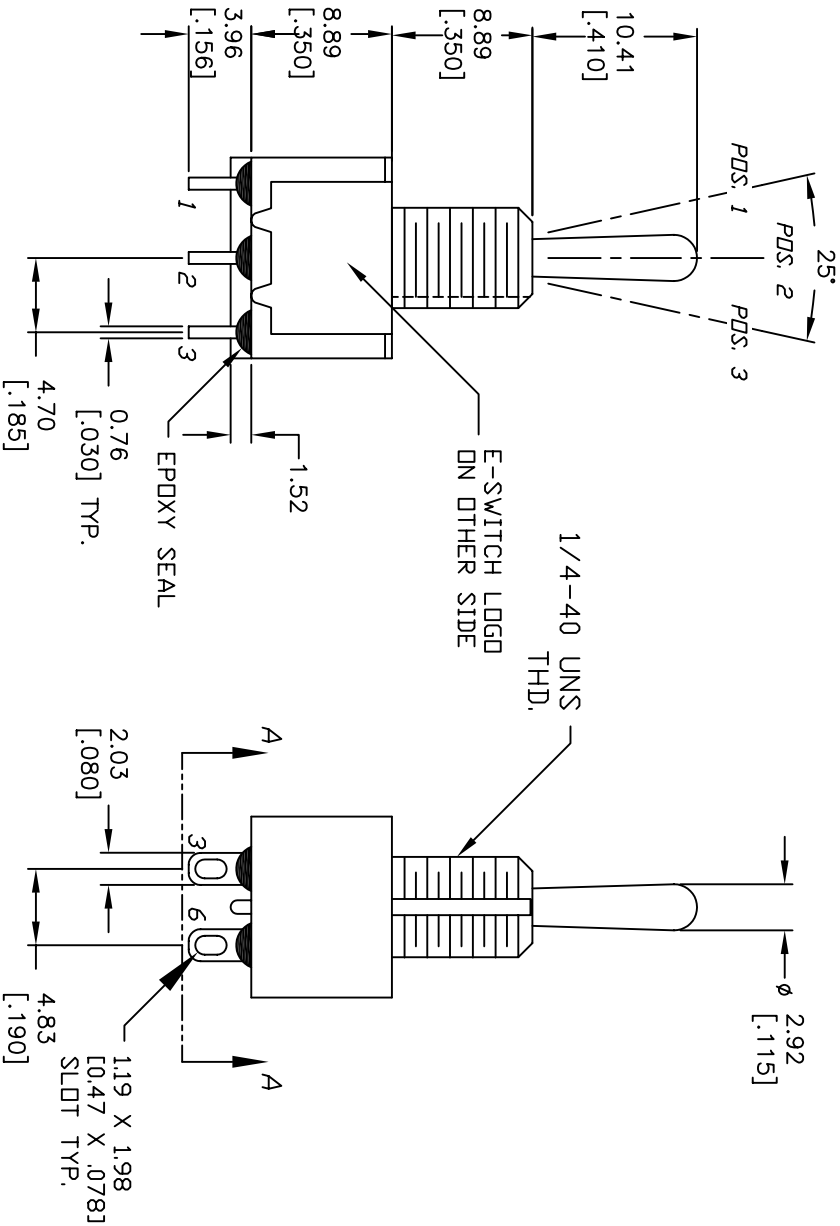
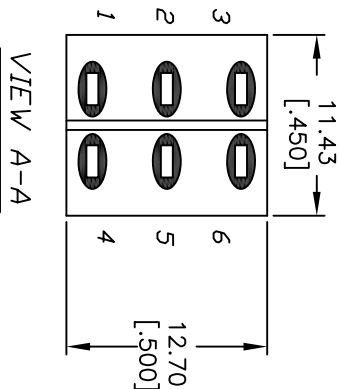
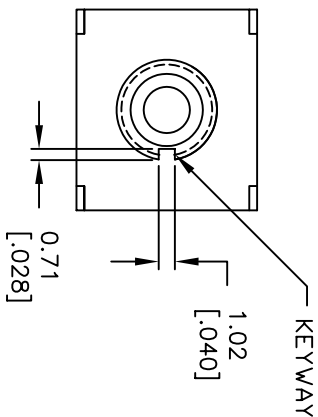

E-SWITCH®

100 DP-1 T1 B1 M1 Q EH

REV. A	ECN NO. 15753	RELEASED FOR PRODUCTION	2/10/06	PH
		DESCRIPTION	DATE	CHKD

TITLE	SCALE 2:1	DATE 2/10/06	DR PH	DWG ST121005	REV A
-------	-----------	--------------	-------	--------------	-------

THE INFORMATION CONTAINED IN THIS DOCUMENT IS PROPRIETARY TO E-SWITCH AND IS NOT TO BE COPIED OR TRANSMITTED