

General Specifications

Electrical Capacity (Resistive Load)

Power Level: 10A @ 125V AC or 6A @ 250V AC or 10A @ 30V DC

Other Ratings

Contact Resistance: 10 milliohms maximum for solder lug & screw terminal models;
30 milliohms maximum for wire lead terminal models

Insulation Resistance: 200 megohms minimum @ 500V DC

Dielectric Strength: 1,500V AC minimum for 1 minute minimum

Mechanical Life: 50,000 operations minimum for On-None-Off, On-None-On, & On-Off-On models
30,000 operations minimum for all other models

Electrical Life: 15,000 operations minimum

Angle of Throw: 24°

Materials & Finishes

Toggle: Brass with chrome plating

Bushing & Outer Case: Fiberglass reinforced polyamide (UL94V-0)

Inner Case: Melamine

Inner Sealing Ring: Nitrile butadiene rubber for On-None-Off, On-None-On, & On-Off-On models;
silicone rubber for all other models

Outer Sealing Ring: Natural rubber

Movable Contactor: Copper with silver plating

Movable Contacts: Silver alloy plus copper with silver plating

Stationary Contacts: Silver alloy plus copper with silver plating

Terminals: Copper with tin plating for solder lug & wire lead; brass with silver plating for screw lug

Wire Lead Covers: Heat resistant polyvinyl chloride (Leads are AWG 16)

Environmental Data

Operating Temp Range: -30°C through +70°C (-22°F through +158°F)

Humidity: 90 ~ 95% humidity for 96 hours @ 40°C (104°F)

Vibration: 10 ~ 55Hz with peak-to-peak amplitude of 1.5mm traversing the frequency range
& returning in 1 minute; 3 right angled directions for 2 hours

Shock: 50G (490m/s²) acceleration (tested in 6 right angled directions, with 5 shocks in each direction)

Front Panel Seal: IP67 of IEC60529, dust tight & water protected during temporary immersion for all models;
optional toggle boot AT401 for additional protection (details at end of WT section)

Behind Panel Seal: IP60 of IEC60529, dust tight but not water protected
for solder lug & screw terminal models
IP67 of IEC60529, dust tight & water protected during temporary immersion
for wire lead models

Installation

Soldering Time & Temp: Manual Soldering: See Profile A in Supplement section.

Mounting Torque: 1.47Nm (13 lb•in)

Standards & Certifications

Flammability Standards: UL94V-0 outer case

Wiring Material Standards: UL AWM 1015 Recognized at Flammability VW-1;
Temperature Range -20°C ~ +105°C; Maximum Load 600V; AWG 16.
CSA TEW 105 Certified at Temperature Range -20°C ~ +105°C;
Maximum Load 600V

Distinctive Characteristics

Sealing for wire lead models meets IP67 of IEC60529 Standards at front and back panel.

Sealing for solder lug or screw lug models meets IP67 at front panel and IP60 at back panel.

Single unit construction of bushing and case gives added protection from environmental elements.

Epoxy sealed base covered by outer case doubles protection from dust and water (not operable under water or oil).

Specially designed contact mechanism that breaks light contact welds for circuits 11, 12, 21 and 22.

Interlocked movable contact mechanism provides highly reliable switching by minimizing contact bounce over center contact.

Heat resistant resin used for outer housing meets UL94V-0 flammability standard and provides high arc and tracking resistance.

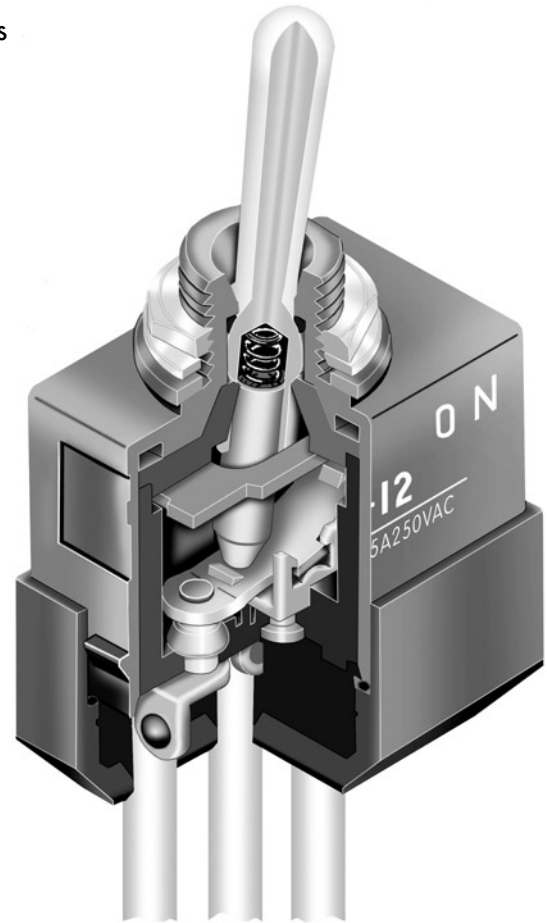

Actual Size

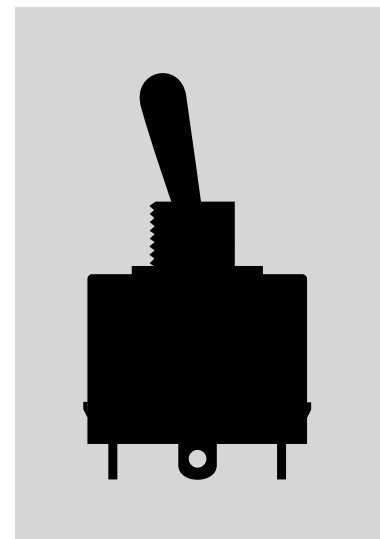

A
Toggles

Rockers

Pushbuttons

Illuminated PB

Programmable

Keylocks

Rotaries

Slides

Tactiles

Tilt

Touch

Indicators

Accessories

Supplement

TYPICAL SWITCH ORDERING EXAMPLE

WT **2** **2** **S**

Poles	
1	SPST SPDT
2	DPST DPDT

Circuits			
1	ON	NONE	OFF
2	ON	NONE	ON
3	ON	OFF	ON
5	ON	NONE	(ON)
8	(ON)	OFF	(ON)
9	ON	OFF	(ON)

Terminals	
S	Solder Lug*
T	Screw Lug
L	Wire Lead

() = Momentary

* Wire harness & cable assemblies offered only in Americas

DESCRIPTION FOR TYPICAL ORDERING EXAMPLE

WT22S

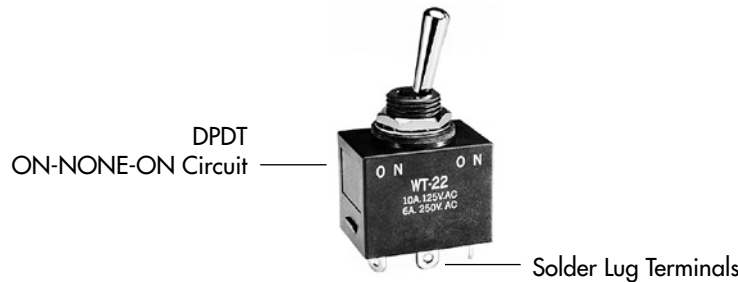

POLES & CIRCUITS

Pole	Model	Toggle Position () = Momentary			Connected Terminals			Throw & Schematics
		Down <small>Flat</small>	Center	Up	Down <small>Flat</small>	Center	Up	
SP	WT11	ON	NONE	OFF	1a-1b	OPEN	OPEN	SPST
SP	WT12 WT13 WT15 WT18 WT19	ON ON ON (ON) ON	NONE OFF NONE OFF OFF	ON ON (ON) (ON) (ON)	1-1b	OPEN	1-1a	SPDT
DP	WT21	ON	NONE	OFF	1a-1b 2a-2b	OPEN	OPEN	DPST
DP	WT22 WT23 WT25 WT28 WT29	ON ON ON (ON) ON	NONE OFF NONE OFF OFF	ON ON (ON) (ON) (ON)	1-1b 2-2b	OPEN	1-1a 2-2a	DPDT

TYPICAL SWITCH DIMENSIONS

Single Throw • Solder Lug

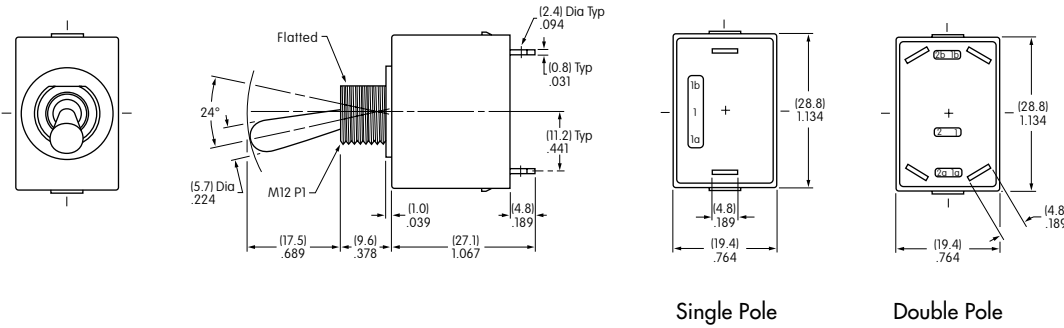

WT11S

Double Throw • Solder Lug

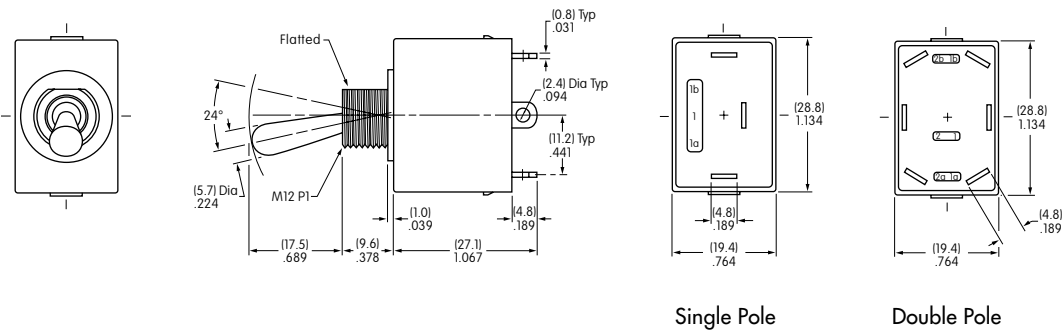

WT22S

Single Throw • Screw Lug

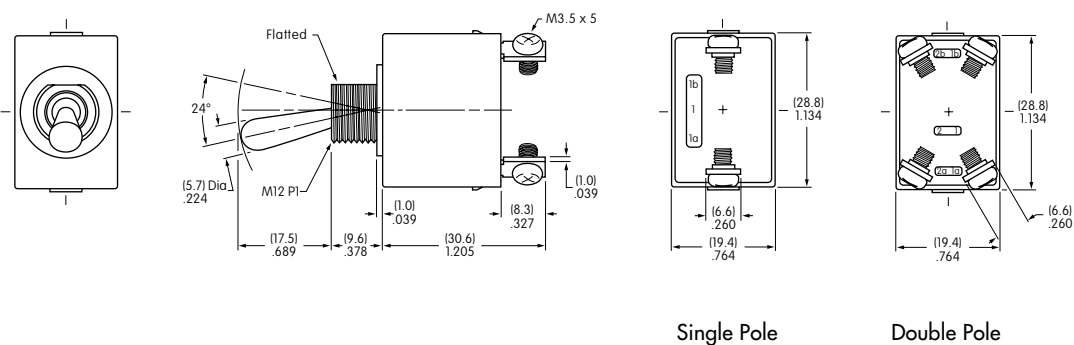

WT21T

TYPICAL SWITCH DIMENSIONS

Double Throw • Screw Lug



WT22T

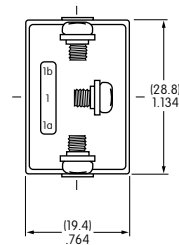
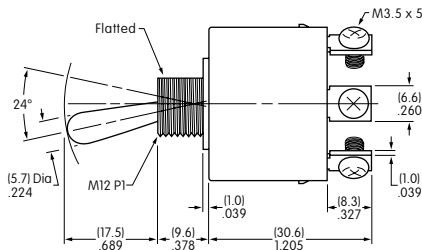
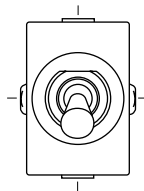

Single Pole

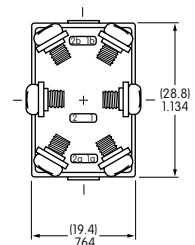

Double Pole

Single & Double Pole • Wire Lead



WT22L

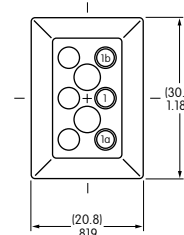
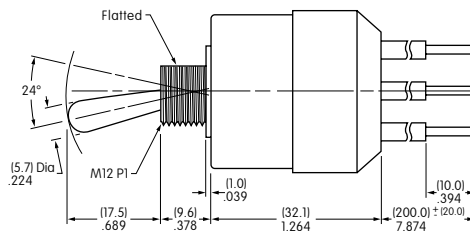
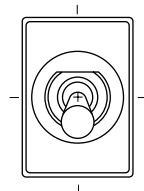

Single Pole

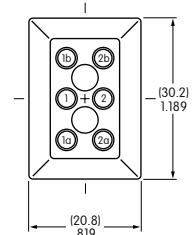

Double Pole

STANDARD WIRE COLOR SCHEME

Wire leads are covered with heat resistant vinyl in accordance to UL 1015 and CSA TEW 105 Standards for Appliance Wiring Material (AWM).

	Terminal Numbers & Wire Colors					
	1a	1	1b	2a	2	2b
WT11	Black		White			
WT12-19	White	Black	Red			
WT21	Black		White	Blue		Yellow
WT22-29	White	Black	Red	Yellow	Blue	Green

PANEL CUTOUT & THICKNESS

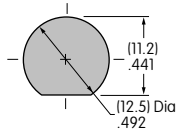

Maximum Effective Panel Thickness

With Standard Hardware: .157" (4.0mm)
 With optional Boot Assembly AT401A/H/S: .063" (1.6mm)
 With optional Boot Assembly AT4181: .083" (2.1mm)

STANDARD HARDWARE

AT503M Hex Face Nut

Material: Brass with Chrome Plating
 1 supplied with each switch

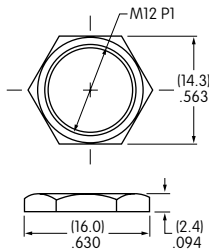

AT508 Internal Tooth Lockwasher

Material: Steel with Zinc/Chromate
 1 supplied with each switch

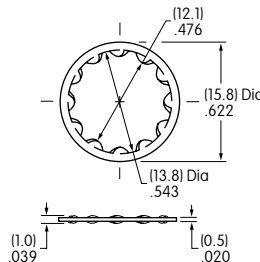

AT401P O-ring

Material: Natural Rubber
 1 supplied with each switch

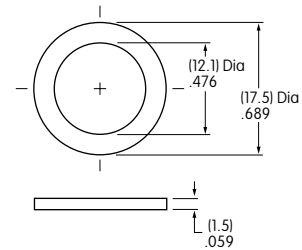

OPTIONAL ACCESSORIES

Boot Assemblies for High Particulate Contamination Applications

AT401A for Oil Resistance

Boot Material: Black nitrile butadiene rubber
 Hex Nut Material & Finish: Nickel plated brass
 O-ring Material: Natural rubber

AT401H for Dust & Ozone Resistance

Boot Material: Gray ethylene propylene rubber
 Hex Nut Material & Finish: Nickel plated brass
 O-ring Material: Natural rubber

AT401S for Retention of Flexibility, Resilience & Tensile Strength Over Wide Temperature Range

Boot Material: Black silicone rubber
 Hex Nut Material & Finish: Nickel plated brass
 O-ring Material: Natural rubber

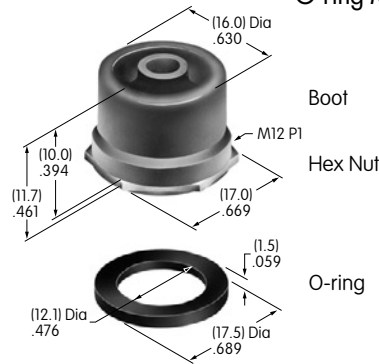
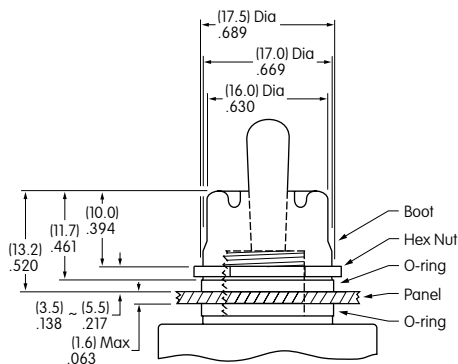

AT4181 Splashproof Boot Assembly ← NEW

Boot Material: Black Silicon rubber
 Nut Material & Finish: Nickel plated brass
 O-ring Material: Natural rubber

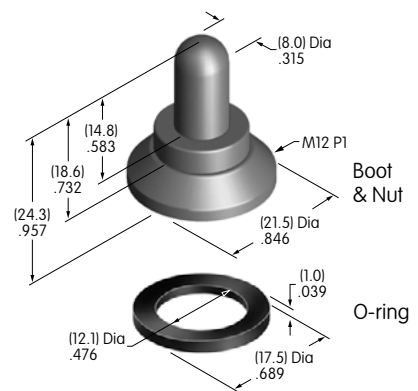
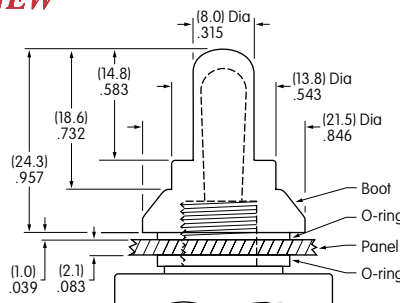

Note: When using boot assemblies AT401A/H/S or AT4181, also use o-ring AT401P from the standard hardware supplied. Hex face nut AT503M and lockwasher AT508 are not used with these boot assemblies.