

4 3 2 1

THIS DRAWING IS UNPUBLISHED. RELEASED FOR PUBLICATION. ALL RIGHTS RESERVED.

LOC	DIST	REVISIONS		DATE	BY	APP'D
AD	00	P	LTR	DESCRIPTION		
		A3		REVISED PER ECO-11-004587	11MAR11	RK HMR

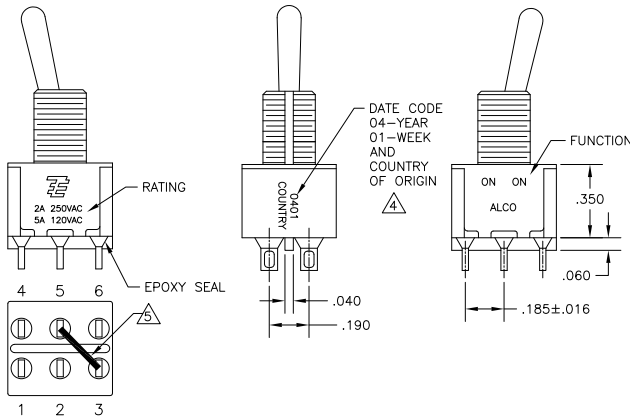
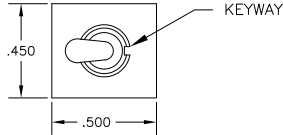

NOTES:

- ALL MATERIALS AND FINISHES SHALL COMPLY WITH EU DIRECTIVE 2002/95/EC OF 27JAN2003 (ROHS).
  - EACH SWITCH WITH THREADED BUSHINGS SUPPLIED WITH THE FOLLOWING MOUNTING HARDWARE: (2) HEX NUTS (1) INTERNAL TOOTH LOCKWASHER (1) LOCATING RING.
  - G CONTACT OPTION CAN BE USED FOR SIGNAL OR POWER LEVEL SWITCHING. IF SWITCH IS USED AT LEVELS EXCEEDING .4VA @ 20V AC/DC, SWITCH IS RENDERED FOR POWER SWITCHING ONLY DUE TO ARC REMOVAL OF GOLD PLATING. RATING STAMPED ON FRAME IS 2A 250VAC, 5A 120VAC.
- △ DATE CODE AND COUNTRY OF ORIGIN MAY APPEAR ON EITHER SIDE OF SWITCH.
- △ SP3T FUNCTION ACHIEVED WITH FUNCTIONS 11, 13 & 15 BY CUSTOMER APPLIED JUMPER BETWEEN TERMINALS 3 AND 5.
- △ LENGTH OF TOGGLE REDUCED BY .020 WITH A, AV2, V30 OR V40 VERTICAL SUPPORT BRACKET.

SPECIFICATIONS CHART

RATING, B CONTACTS	.4VA MAX @20V MAX. AC OR DC
RATING, G CONTACTS—SEE NOTE 3	.4VA MAX @20V MAX. AC OR DC OR 5A @120 VAC OR 28 VDC (RESISTIVE) 2A @250 VAC (RESISTIVE)
RATING, Q CONTACTS	5A @120 VAC OR 28 VDC (RESISTIVE) 2A @250 VAC (RESISTIVE)
ELECTRICAL LIFE	6,000 CYCLES AT RATED LOAD
CONTACT RESISTANCE	10 MILLIOHMS MAX INITIAL @ 2-4VDC, 100ma
INSULATION RESISTANCE	1,000 MEGOHMS MIN
DIELECTRIC WITHSTANDING VOLTAGE	1,000 V RMS AT SEA LEVEL
OPERATING TEMPRATURE	-30C TO 85C

FUNCTION CHART

FUNCTION	1 2 3 4 5 6	1 2 3 4 5 6	1 2 3 4 5 6
03	ON	OFF	ON
05	(ON)	OFF	(ON)
07	ON	OFF	(ON)
TERMINALS CONNECTED	2-3, 5-6	---	1-2, 4-5
11	ON	ON	ON
13	ON	ON	(ON)
15	(ON)	ON	(ON)
TERMINALS CONNECTED	2-3, 5-6	2-3, 4-5	1-2, 4-5
SP3T SCHEMATIC (11, 13 & 15 ONLY) SEE NOTE 5			
None: No mechanical position Off: Mechanical position with no electrical connection (On): Momentary action	IN 2, OUT 6	IN 2, OUT 4	IN 2, OUT 1

PART NUMBER SEQUENCE CHART

MODEL	FUNCTION	TOGGLE	BUSHING	TERMINAL	CONTACT	RoHS
A2	03	K	CW	A	B	04
	05	K1	D	AV2	G	
	07	L	D9	C	Q	
	11	L1	H	V30		
	13	L2	Y	V40		
	15	M	Y9	V70		
		P3		W		
		S		W4		
		T		Z		
		T1		Z3		

EXAMPLE: A207SYZQ04

DIMENSIONS:		OTHER DIMENSIONS:		APPLICATION SPEC:		SIZE		DATE CODE		DRAWING NO.		RESTRICTED TO	
INCHES		MILLIMETERS		MATERIAL		WEIGHT		SCALE		SHEET		REV	
-		-		-		-		3:1		1 of 4		A3	

TE Connectivity  
GEMINI A SERIES TOGGLE SWITCH, DOUBLE POLE, 3 POSITION FUNCTIONS (03, 05, 07, 11, 13 & 15)  
A2 00779 ©=1825139

4

3

2

1

THIS DRAWING IS UNPUBLISHED. RELEASED FOR PUBLICATION. ALL RIGHTS RESERVED.

### TOGGLES

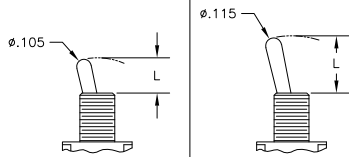

**M** SHORT      **S** STANDARD

DIM L	BUSHING TYPE	DIM L	BUSHING TYPE
.200	Y, H	.410	Y, H
.270	D, D9	.480	D, D9

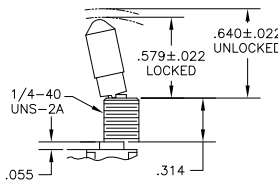

**K** NO BUSHING OPTION NEEDED

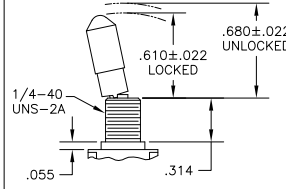

**K1** NO BUSHING OPTION NEEDED

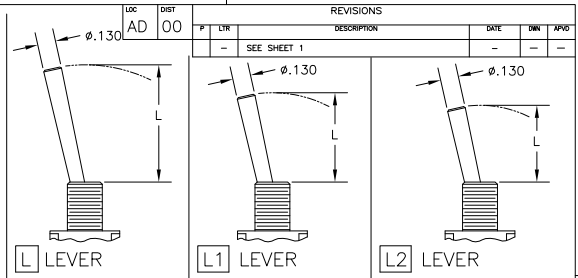

DIM L	BUSHING TYPE	DIM L	BUSHING TYPE	DIM L	BUSHING TYPE
.840	Y, H	.640	Y, H	.550	Y, H
.910	D, D9	.710	D, D9	.620	D, D9

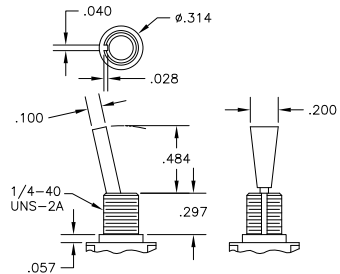

**P3** NO BUSHING OPTION NEEDED

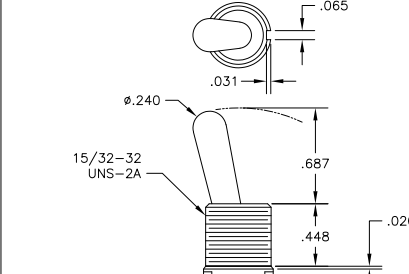

**T** NO BUSHING OPTION NEEDED

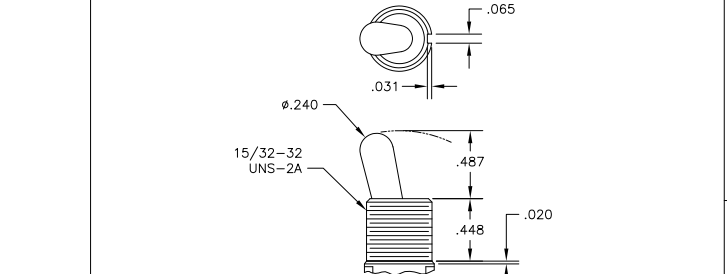

**T1** NO BUSHING OPTION NEEDED

### BUSHINGS

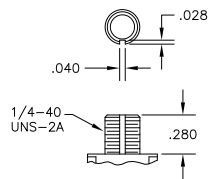

**D** THREADED  
**D9** UNTHREADED

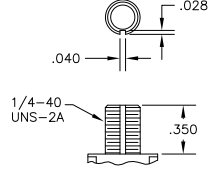

**Y** THREADED  
**Y9** UNTHREADED

CONTAINS O-RING BETWEEN TOGGLE AND BUSHING AND BETWEEN BUSHING AND PANEL

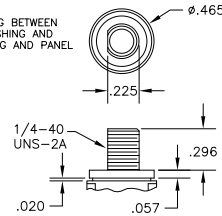

**CW** THREADED SPLASHPROOF

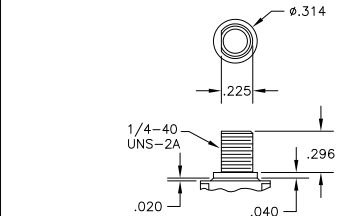

**H** HIGH TORQUE

THIS DRAWING IS A CONTROLLED DOCUMENT. DIM: M. ZITTO 14MPROD. CHK: M. ZITTO. NAME: GEMINI A SERIES TOGGLE SWITCH, DOUBLE POLE, 3 POSITION FUNCTIONS (03, 05, 07, 11, 13 & 15). APPLICATION SPEC: PRODUCT SPEC: SIZE: CAGE CODE: DRAWING NO: A2 00779 © 1825139. WEIGHT: RESTRICTED TO: CUSTOMER DRAWING. SCALE: 2:1. SHEET: 2 of 4. REV: A3.

4

3

2

1

THIS DRAWING IS UNPUBLISHED. RELEASED FOR PUBLICATION  
 © COPYRIGHT - By - ALL RIGHTS RESERVED.

LOC	DIST	REVISIONS			
P	LTR	DESCRIPTION	DATE	BY	APPD
AD	00	SEE SHEET 1	-	-	-

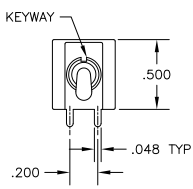

**AV2** VERTICAL RIGHT ANGLE  $\triangle$

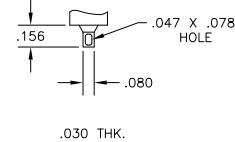
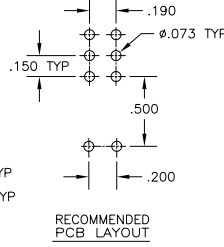
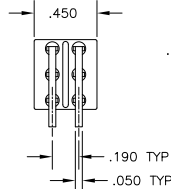
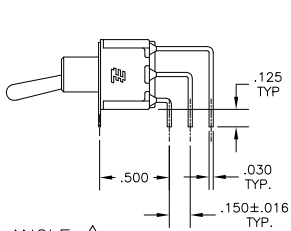

**Z** WIRE LUG

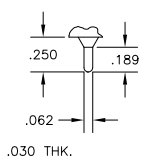

**Z3** QUICK CONNECT

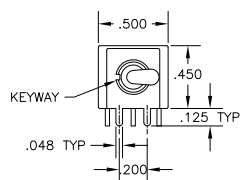

**A** RIGHT ANGLE  $\triangle$

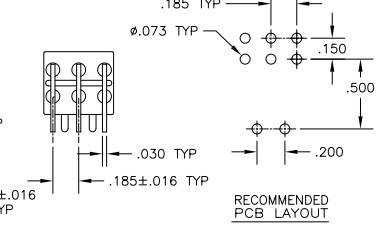
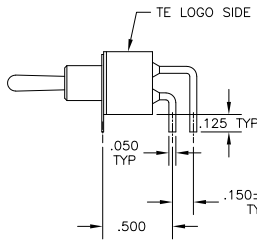

OPTION	DIM A
W	.736
W4	1.062

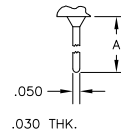

**W** W4 WIRE WRAP

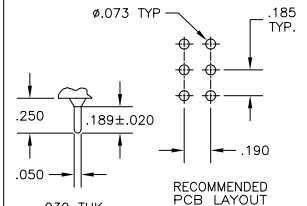

**C** PRINTED CIRCUIT

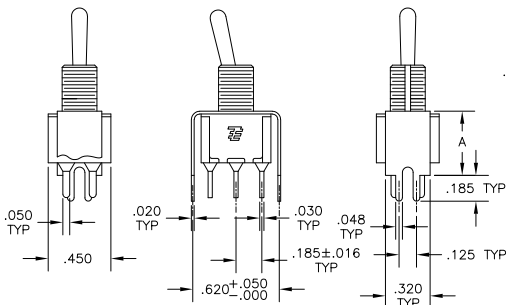

**V30 V40**  $\triangle$   
VERTICAL SUPPORT BRACKET

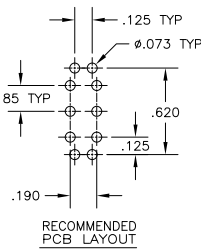

OPTION	DIM A
V30	.460
V40	.630

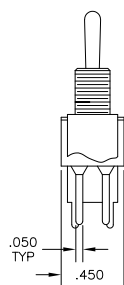

**V70**  
VERTICAL SUPPORT BRACKET

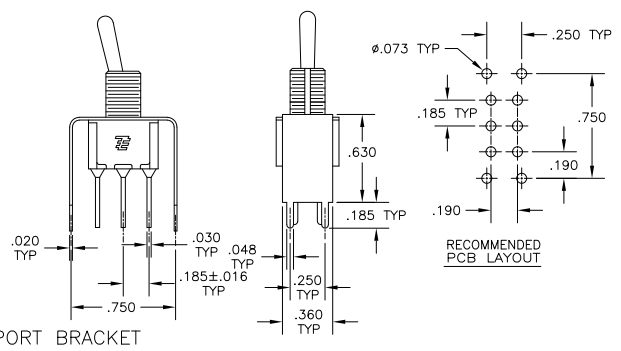

THIS DRAWING IS A CONTROLLED DOCUMENT.		BY: M. ZITTO	14MPROD	TE Connectivity	
DIMENSIONS: INCHES		CHK: M. ZITTO	NAME: GEMINI A SERIES TOGGLE SWITCH, DOUBLE POLE, 3 POSITION FUNCTIONS (03, 05, 07, 11, 13 & 15)	RESTRICTED TO: -	
TOLERANCES UNLESS OTHERWISE SPECIFIED:		APP: M. ZITTO	PRODUCT SPEC: -	SCALE: 2:1	
Ø PLC ± .005	PLC ± .005	APPLICATION SPEC: -	SIZE: A2	CAGE CODE: 00779	DRAWING NO: 1825139
Ø PLC ± .010	PLC ± .010	WEIGHT: -	CUSTOMER DRAWING		
Ø PLC ± .015	PLC ± .015	FINISH: -	SHEET 3 of 4		
ANGLES ± .5°	ANGLES ± .5°	REV: A3			

4

3

2

1

THIS DRAWING IS UNPUBLISHED. RELEASED FOR PUBLICATION. ALL RIGHTS RESERVED.

LOC	DIST	REVISIONS					
AD	00	P	LHR	DESCRIPTION	DATE	MIN	APD
		-	-	SEE SHEET 1		-	-

Alco P/N	P/N
A203KZQ04	1825139-1
A203MD9AB04	1825139-2
A203P3AV2Q04	1825139-3
A203P3ZQ04	1825139-4
A203SD9AV2B04	1825139-5
A203SD9AV2Q04	1825139-6
A203SDZQ04	1825139-7
A203SYCB04	1825139-8
A203SYCQ04	1825139-9
A203SYZQ04	1-1825139-0
A203T1ZQ04	1-1825139-1
A203TZQ04	1-1825139-2
A205KZB04	1-1825139-3
A205P3ZQ04	1-1825139-4
A205SD9AB04	1-1825139-5
A205SYCB04	1-1825139-6
A205SYCQ04	1-1825139-7
A205SYZQ04	1-1825139-8
A205T1ZQ04	1-1825139-9
A205TZQ04	2-1825139-0
A207P3ZQ04	2-1825139-1
A207SYCB04	2-1825139-2
A207SYCQ04	2-1825139-3
A207SYZQ04	2-1825139-4
A207T1ZQ04	2-1825139-5
A207TZQ04	2-1825139-6
A211KZB04	2-1825139-7
A211MD9AQ04	2-1825139-8
A211MYCQ04	2-1825139-9
A211P3CQ04	3-1825139-0
A211P3V40G04	3-1825139-1
A211P3ZQ04	3-1825139-2
A211SCWCO04	3-1825139-3
A211SDZQ04	3-1825139-4
A211SHZQ04	3-1825139-5
A211SY9AQ04	3-1825139-6
A211SYCQ04	3-1825139-7
A211SYZB04	3-1825139-8
A211SYZQ04	3-1825139-9
A211T1ZQ04	4-1825139-0
not assigned	4-1825139-1
A213SYZQ04	4-1825139-2
A215SD9V30B04	4-1825139-3
A215SY9AQ04	4-1825139-4
A215SYZQ04	4-1825139-5

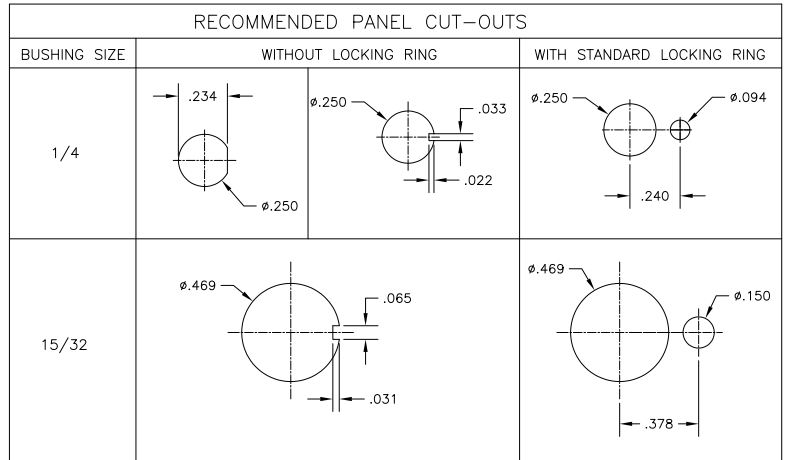

MATERIALS CHART		
COMPONENT NAME	BASE MATERIAL	FINISH
CASE	DAP, RED, UL94 V-0	
FRAME	STAINLESS STEEL	
B TERMINALS & CONTACTS	COPPER	GOLD OVER NICKEL
G TERMINALS & CONTACTS	COPPER	GOLD OVER SILVER
Q TERMINALS & CONTACTS	COPPER	.000400 SILVER
ACTUATOR	PHENOLIC, BLACK, UL94 V-1	
LEVER	BRASS	CHROME
BUSHING	BRASS	NICKEL
SPRING	MUSIC WIRE	
SUPPORT BRACKET	BRASS	TIN
PIVOT PIN	STEEL	NICKEL
LOCK WASHER	STAINLESS STEEL	
LOCKING RING	STAINLESS STEEL	
NUTS	C3604BD BRASS	NICKEL
TERMINAL SEAL	EPOXY	

THIS DRAWING IS A CONTROLLED DOCUMENT. 14APR02

DIMENSIONS: INCHES 	TOLERANCES UNLESS OTHERWISE SPECIFIED: 0 PLC ± .005 1 PLC ± .005 2 PLC ± .005 3 PLC ± .010 4 PLC ± .010 ANGLES ± 2° FINISH	DRN M. ZITTO CRK M. ZITTO M. ZITTO APD M. ZITTO PRODUCT SPEC APPLICATION SPEC WEIGHT	TE Connectivity GEMINI A SERIES TOGGLE SWITCH, DOUBLE POLE, 3 POSITION FUNCTIONS (03, 05, 07, 11, 13 & 15) SIZE CASE CODE DRAWING NO A200779C-1825139 RESTRICTED TO CUSTOMER DRAWING SCALE 3:1 SHEET 4 of 4 REV A3
---------------------------	---	--	--