

DATA MCS 18, SSM 27 SWITCHES – MOMENTARY ACTION



BENEFITS

- Unique mechanical switches with tactile feedback
- Extremely high life time of 5 million switching cycles (SSM)
- Small mounting depth
- Various lettering options
- No mechanical stress of the switching elements due to magnetic switching principle (SSM)
- Front and rear tested to degree of protection IP 65

	MCS 18 gold contacts	MCS 18 silver contacts	SSM 27
Electrical data			
Contact material	gold	silver	AuNi
Switching voltage	min. 50 DC max. 24 DC	min. 5V DC max. 48 DC	min. 3V DC max. 50 DC
Switching current max.	80	125	50
Rated breaking capacity	0.36	0.72	2.5
Lifetime (at rated breaking capacity)	> 10 ⁶	> 10 ⁶	5 Mio.
Initial contact resistance, new	< 50	< 50	*
Initial contact resistance, after lifetime	< 150	< 150	*
Insulation resistance	> 10 ⁸	> 10 ⁸	*
Contact bounce time	typ. 0.1	typ. 0.1	typ. 1
ESD resistance	± 16	± 16	± 16
Mechanical data			
Actuating force	3 ± 1	3 ± 1	2.8
Contact travel	0.5 ± 0.1	0.5 ± 0.1	0.30
End stop strength	> 50	> 50	IK 03
Lifetime	> 1 Mio.	> 1 Mio.	> 5 Mio.
Other data			
Soldering method	Hand soldering	Hand soldering	
Soldering heat resistance	350/3	350/3	
Ambient temperature	-25 – +60	-25 – +60	-25 – +85
Storage temperature	-25 – +60	-25 – +60	-25 – +85
Degree of protection	IP 65	IP 65	IP 65
Recommended torque	8	8	250
Materials			
Socket/Housing (SSM 27)	Thermoplast PES	Thermoplast PES	Alu anodized
Face foil	PETP	PETP	PETP
Bezel	Thermoplast PBTP	Thermoplast PBTP	Alu anodized
Contact material gold / silver	CuZn 37, 3 μm Ni 2 μm Au	CuZn 37, 2.5 μm Ag	Au Ni
Soldering aid	tinned	tinned	

* on request

DIMENSIONS MCS 18, SSM 27 SWITCHES – MOMENTARY ACTION

CONSTRUCTION

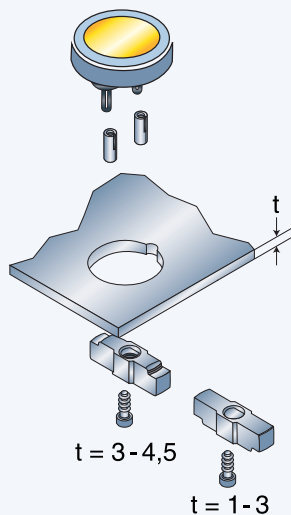

MCS 18

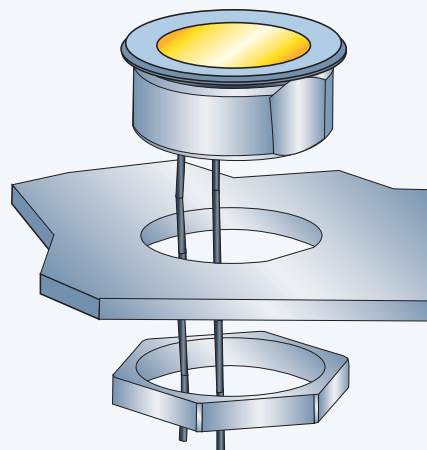

SSM 27

DIMENSIONS

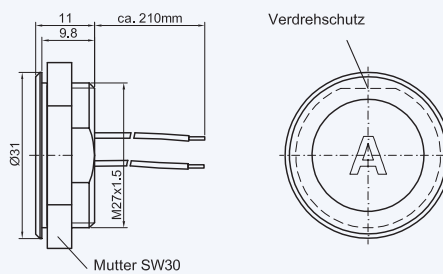
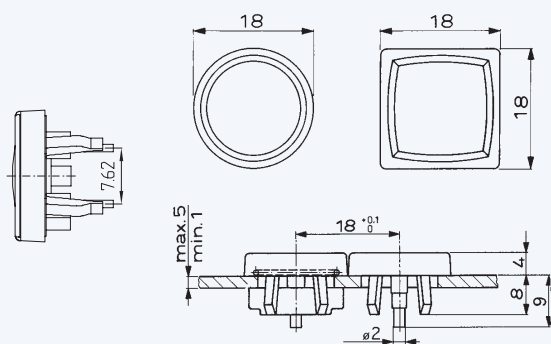

DRILLING DIAGRAM

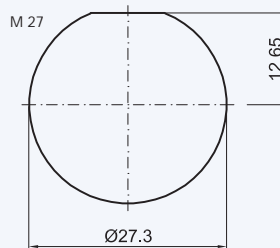
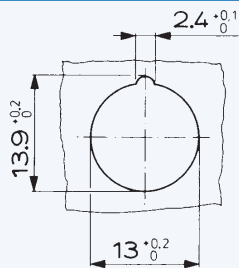

CIRCUIT DIAGRAM

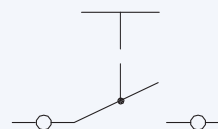
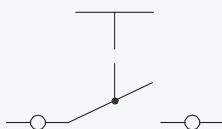

OVERVIEW MCS 18, SSM 27 SWITCHES – MOMENTARY ACTION



MCS 18

MCS 18

SSM 27

FEATURES

Contact material	Ag	Au	Au
Degree of protection	IP 65	IP 65	IP 65

PART NUMBER *

square	1241.1100.	x	xxx	1241.1102.	x	xxx		
round	1241.1104.	x	xxx	1241.1106.	x	xxx	1245.2112.43100	xxx
square with soldering aid	1241.1112.	x	xxx					
round with soldering aid	1241.1113.	x	xxx					
Colour of bezel								
red		3			3			
grey		6			6			
black		7			7			
alu natural								○
Colour of face foil								
red								093
green								095
Colour of face foil without legend								
yellow			091			091		
red			093			093		
green			095			095		
grey			096			096		
black			097			097		
white			098			098		
Standard lettering								
Order index	see page 29			see page 29			see page 29	
Accessories								
IP 65 to the front	0098.9201			0098.9201			**	

* X in the Part No. must be replaced by the desired version
 ** Nut and O-ring are included
 ○ Standard version

FRONT PANEL
SHORT STROKE



LETTERING

Depending on the application and font, there are various lettering possibilities. The following standards can be used for key letterings:

ORDER INDEX LETTERING

A = 001	P = 016	4 = 031	↑ = 046	EIN = 061
B = 002	Q = 017	5 = 032	→ = 047	AUS = 062
C = 003	R = 018	6 = 033	← = 048	AUF = 063
D = 004	S = 019	7 = 034	↓ = 049	AB = 064
E = 005	T = 020	8 = 035	↑ = 050	ON = 065
F = 006	U = 021	9 = 036	% = 051	OFF = 066
G = 007	V = 022	+ = 037	√ = 052	UP = 067
H = 008	W = 023	- = 038	CTRL = 053	DOWN = 068
I = 009	X = 024	· = 039	RETURN = 054	HIGH = 069
J = 010	Y = 025	x = 040	SHIFT = 055	LOW = 070
K = 011	Z = 026	÷ = 041	LOCK = 056	ON/OFF = 071
L = 012	0 = 027	* = 042	STOP = 057	START = 072
M = 013	1 = 028	= = 043	ENTER = 058	
N = 014	2 = 029	# = 044	BACK = 059	
O = 015	3 = 030	↔ = 045	LINE = 060	

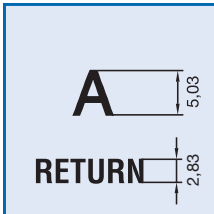

MCS 18, LETTER HEIGHTS AND FONTS

- Single characters, Univers 65
- Legends max. 6 characters in line, Univers 65
- Insert label and front foil anthracite, RAL 7016
- Characters and symbols light grey, RAL 7035

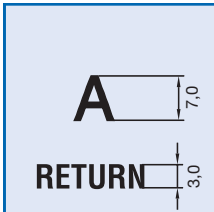

SSM 27, LETTER HEIGHTS AND FONTS

- Single characters, Univers 65
- Legends max. 6 characters in line, Akzident-Grotesk condensed bold type
- Front foil anthracite, RAL 7016
- Characters and symbols light grey, RAL 7035



LIGHTING TECHNOLOGY

TECHNICAL DATA LEDs

1. Maximum ratings				
Part number		0925.9730	0925.9731	0925.9732
Light colour		red	green	yellow
Forward current, DC	I_f max. [mA]	40	40	40
Power dissipation	P_{tot} max. [mW]	130	130	130
2. Characteristics (typ. at $T_u = 25\text{ °C}$)				
Forward voltage	at $I_f = 10\text{ mA}$, U_f typ. [mA]	2.0 (< 2.6)	2.0 (< 2.6)	2.0 (< 2.6)
Luminous intensity	at $I_f = 10\text{ mA}$, I_v typ. [mcd]	11.2 - 28	18 - 45	11.2 - 28
Viewing angle	typ. [Degree]	50	50	50
Peak wave length	λ_{peak} typ. [nm]	635	565	586
Reverse voltage	U_R typ. [V]	5	5	5