

SHEET OF

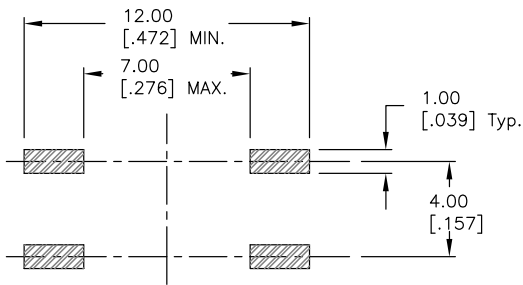

RECOMMENDED P.C.B. LAYOUT

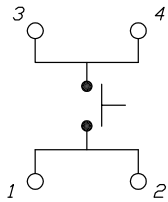
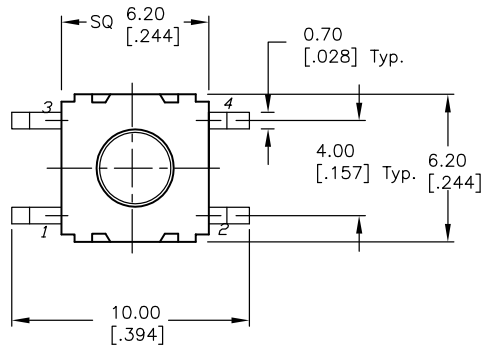

CIRCUIT: SPST
CONTACT CONFIGURATION

NOTES:

1. ALL DIMENSIONS IN MM [INCH]
2. GENERAL TOLERANCE: X.X=±0.4
X.XX=±0.25
3. TERM. NOS. FOR REF. ONLY
4. RATING: 50mA, @12V DC
5. TRAVEL: 0.25 +0.2/-0.1mm
6. CONTACT RESISTANCE: 20 MILLIOHMS INITIAL.
7. ELECTRICAL LIFE: 100,000 CYCLES
- ▲ 8. OPERATING FORCE: 300±50 GF
- ▲ 9. PACKAGING: TAPE AND REEL.
10. ▲ DENOTES CRITICAL PARAMETER.

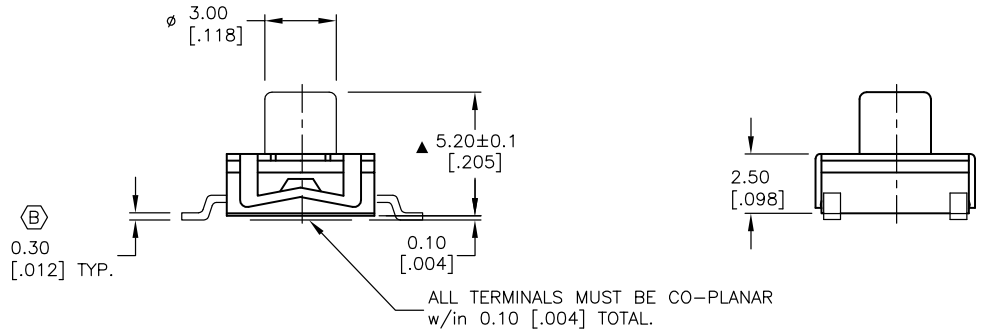

REV.	ECN No.	DESCRIPTION	DATE	CHKD
C	13959	CHANGE DESCRIPTION	4/27/04	AR
B	13623	DIM 0.30 WAS 0.25	11/25/03	AR
A	13379	RELEASED FOR PRODUCTION	8/18/03	AR

THE INFORMATION CONTAINED IN THIS DOCUMENT IS PROPRIETARY TO E-SWITCH AND IS NOT TO BE COPIED OR TRANSFERRED

E-SWITCH®				
TITLE TL6304BF300QG				
SCALE	DATE	DR	DWG	REV
4:1	8/18/03	AR	D310739	C