

RECOMMENDED P.C.B. LAYOUT

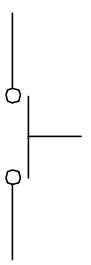

CIRCUIT: SPST

- NOTES:
1. ALL DIMENSIONS IN MM [INCH]
 2. GENERAL TOLERANCE: X.X=±0.4
X.XX=±0.25
 3. CONTACT RATING: 50mA @12V DC
 4. CONTACT MATERIAL: SILVER
 5. OPERATING FORCE: 160±50gf
 6. TRAVEL: 0.25 +0.2/-0.1
 7. CONTACT RESISTANCE: 100mILLI Ohms max.
 8. ELECTRICAL LIFE: 100,000 CYCLES
 9. PACKAGING:
CARRIER IS FOLDED EVERY 25 PITCHES
(24) SWITCHES PER FOLD
(1,000) SWITCHES PER BOX

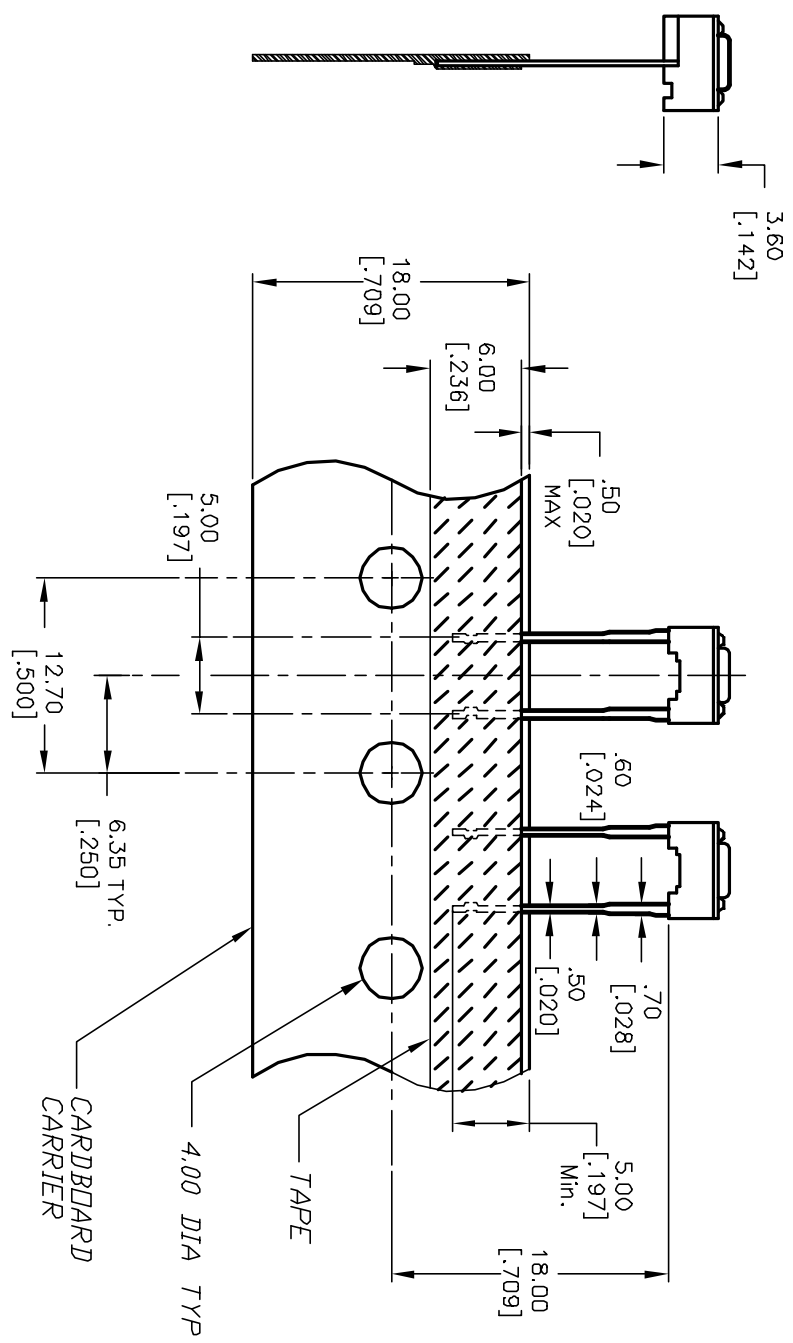

REV.	ECN No.	DESCRIPTION	DATE	CHKD
A	11623	RELEASED FOR PRODUCTION	8/21/01	CB

TITLE	SCALE	DATE	DR	DWG	REV
TL59N F160 Q	2:1	8/21/01	CB	D310560	A

E-SWITCH®

THE INFORMATION CONTAINED IN THIS DOCUMENT IS PROPRIETARY TO E-SWITCH AND IS NOT TO BE COPIED OR TRANSFERRED