

P.C. MOUNTING

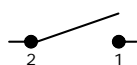

CIRCUIT: SPST

- NOTES:
1. ALL DIMENSIONS IN MM [INCH]
 2. GENERAL TOLERANCE: X.X=±0.4
X.XX=±0.25
 3. TERM. NOS. FOR REF. ONLY
 - ▲4. RATING: 50mA @12VDC
 5. CONTACT MATERIAL: SILVER
 6. TRAVEL: 0.3±0.15mm
 - ▲7. OPERATING FORCE: 160±50gf
 8. CONTACT RESISTANCE: 100mΩ MAX.
 9. ELECTRICAL LIFE: 100,000 CYCLES MIN
 10. ▲ DENOTES CRITICAL DIMENSION
 11. 2002/95/EC (ROHS) COMPLIANT

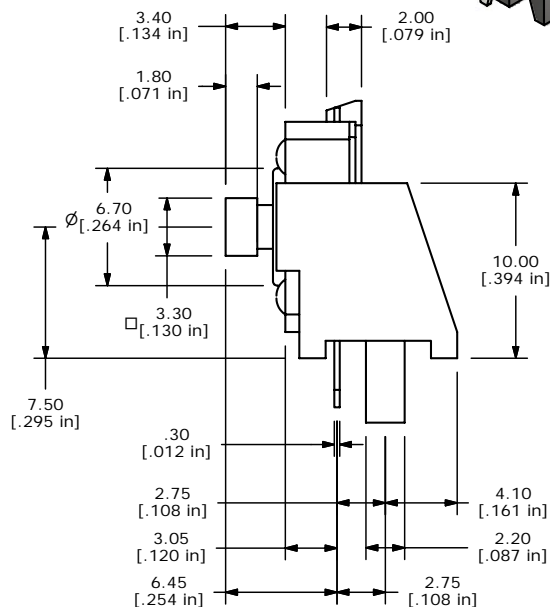
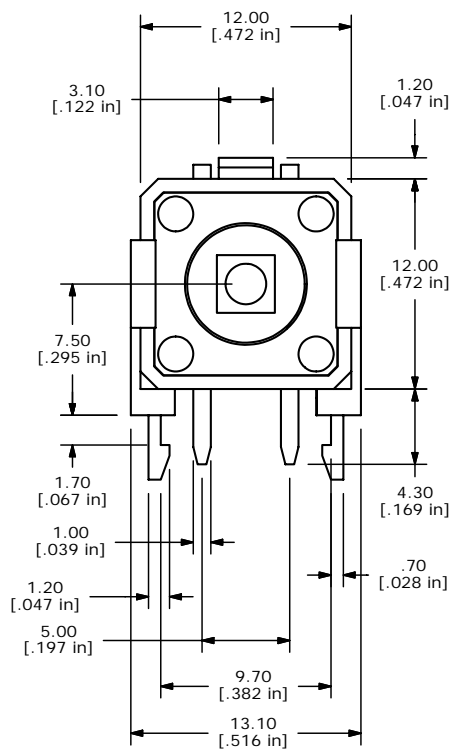

E-SWITCH®

TITLE TL1100CF160Q

D	16649	REVISED AND REDRAWN	11/14/2006	TN
REV	PCR NO	DESCRIPTION	DATE	BY

THE INFORMATION CONTAINED IN THIS DOCUMENT IS PROPRIETARY TO E-SWITCH AND IS NOT TO BE COPIED OR TRANSFERRED

SCALE	DATE	DR	DWG	REV
3:1	11/14/2006	TN	P001110	D