

SHEET 1 OF 1

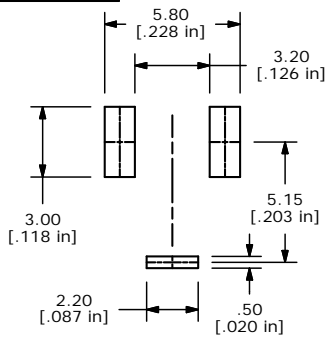

P.C.B. LAYOUT

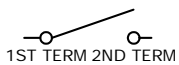

CIRCUIT: SPST

NOTES:

1. ALL DIMENSIONS IN MM [INCH]
2. GENERAL TOLERANCE: X.X=±0.4
X.XX=±0.25
3. TERMINAL NUMBERS FOR REFERENCE ONLY.
4. RATING: 12VDC 50mA
- ▲ 5. OPERATING FORCES: 100±30gf
6. TRAVEL: 0.25±0.1 mm
7. CONTACT RESISTANCE: 100m OHMS MAX
8. INSULATION RESISTANCE: 100M OHMS MIN.
9. DIELECTRIC STRENGTH: 250VAC FOR 1 MINUTE.
10. OPERATING TEMP: -20C TO +70C
11. STORAGE TEMPERATURE: -40C TO + 80C
12. LIFE: 80,000 CYCLES.
- ▲ 13. PACKAGING: TAPE & REEL, 500 PIECES PER REEL.
14. ▲ DENOTES CRITICAL PARAMETER.
15. 2002/95/EC (RoHS) COMPLIANT AND HALOGEN FREE.

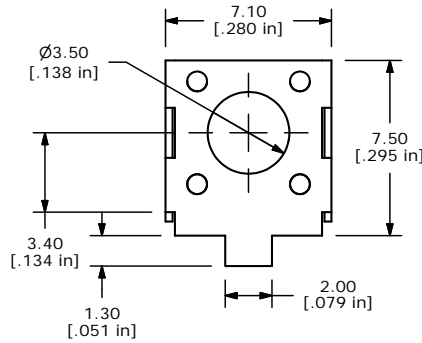
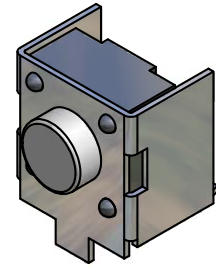
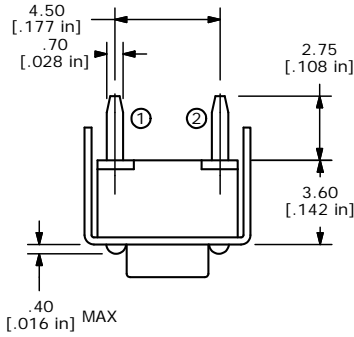

2 (①, ②) SURFACES COPLANAR WITHIN 0.1 mm MAX.

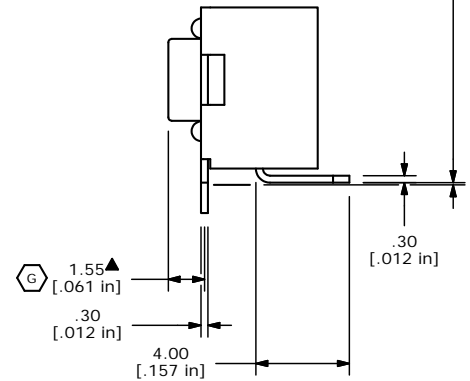

TITLE TL3320BF100Q

G	19632	CHANGE ACTUATOR HEIGHT	01/31/11	BMA
REV	PCR NO	DESCRIPTION	DATE	BY

THE INFORMATION CONTAINED IN THIS DOCUMENT IS PROPRIETARY TO E-SWITCH AND IS NOT TO BE COPIED OR TRANSFERRED

SCALE	DATE	DR	DWG	REV
4:1	3/22/2010	BLR	D320004	G