

**Boost chopper  
Trench IGBT® Power Module**

**$V_{CES} = 1700V$   
 $I_C = 50A @ T_c = 80^\circ C$**

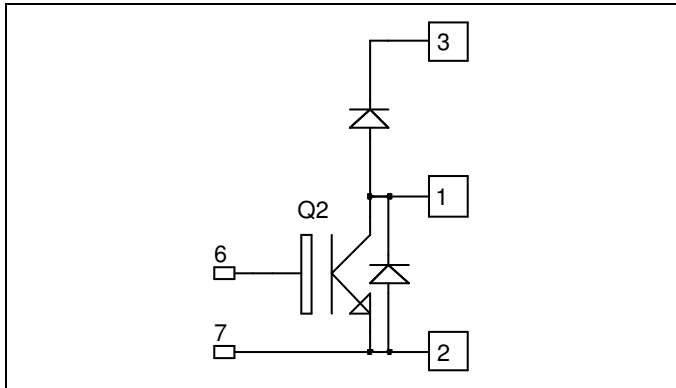

**Application**

- AC and DC motor control
- Switched Mode Power Supplies
- Power Factor Correction

**Features**

- Trench + Field Stop IGBT® Technology
  - Low voltage drop
  - Low tail current
  - Switching frequency up to 20 kHz
  - Soft recovery parallel diodes
  - Low diode VF
  - Low leakage current
  - Avalanche energy rated
  - RBSOA and SCSOA rated
- Kelvin emitter for easy drive
- Low stray inductance
- High level of integration
- Kelvin emitter for easy drive
- Low stray inductance
  - M5 power connectors

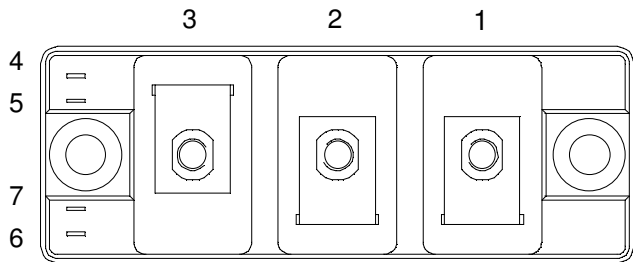

**Benefits**

- Stable temperature behavior
- Very rugged
- Direct mounting to heatsink (isolated package)
- Low junction to case thermal resistance
- Easy paralleling due to positive TC of VCESat

**Absolute maximum ratings**

Symbol	Parameter	Max ratings	Unit
$V_{CES}$	Collector - Emitter Breakdown Voltage	1700	V
$I_C$	Continuous Collector Current	$T_C = 25^\circ C$	70
		$T_C = 80^\circ C$	50
$I_{CM}$	Pulsed Collector Current	$T_C = 25^\circ C$	100
$V_{GE}$	Gate - Emitter Voltage	$\pm 20$	V
$P_D$	Maximum Power Dissipation	$T_C = 25^\circ C$	310
RBSOA	Reverse Bias Safe Operation Area	$T_j = 125^\circ C$	100A@1700V

**CAUTION:** These Devices are sensitive to Electrostatic Discharge. Proper Handling Procedures Should Be Followed.

All ratings @  $T_j = 25^\circ\text{C}$  unless otherwise specified

## Electrical Characteristics

Symbol	Characteristic	Test Conditions	Min	Typ	Max	Unit
$BV_{CES}$	Collector - Emitter Breakdown Voltage	$V_{GE} = 0V, I_C = 2.5mA$	1700			V
$I_{CES}$	Zero Gate Voltage Collector Current	$V_{GE} = 0V, V_{CE} = 1700V$			6	mA
$V_{CE(on)}$	Collector Emitter on Voltage	$V_{GE} = 15V$ $I_C = 50A$		$T_j = 25^\circ\text{C}$ $T_j = 125^\circ\text{C}$	2.0 2.4	V
$V_{GE(th)}$	Gate Threshold Voltage	$V_{GE} = V_{CE}, I_C = 2.5mA$	5.2	5.8	6.4	V
$I_{GES}$	Gate - Emitter Leakage Current	$V_{GE} = 20V, V_{CE} = 0V$			600	nA

## Dynamic Characteristics

Symbol	Characteristic	Test Conditions	Min	Typ	Max	Unit
$C_{ies}$	Input Capacitance	$V_{GE} = 0V, V_{CE} = 25V$		4400		pF
$C_{res}$	Reverse Transfer Capacitance	$f = 1MHz$		150		
$T_{d(on)}$	Turn-on Delay Time	Inductive Switching ( $25^\circ\text{C}$ ) $V_{GE} = \pm 15V$ $V_{Bus} = 900V$ $I_C = 50A$ $R_G = 22\Omega$		200		ns
$T_r$	Rise Time			100		
$T_{d(off)}$	Turn-off Delay Time			750		
$T_f$	Fall Time			90		
$T_{d(on)}$	Turn-on Delay Time	Inductive Switching ( $125^\circ\text{C}$ ) $V_{GE} = \pm 15V$ $V_{Bus} = 900V$ $I_C = 50A$ $R_G = 22\Omega$		230		ns
$T_r$	Rise Time			100		
$T_{d(off)}$	Turn-off Delay Time			850		
$T_f$	Fall Time			115		
$E_{off}$	Turn Off Energy			22		mJ

## Reverse diode ratings and characteristics

Symbol	Characteristic	Test Conditions	Min	Typ	Max	Unit
$V_F$	Diode Forward Voltage	$I_F = 50A$ $V_{GE} = 0V$		$T_j = 25^\circ\text{C}$ $T_j = 125^\circ\text{C}$	1.8 1.9	2.2 V
$E_r$	Reverse Recovery Energy	$I_F = 50A$ $V_R = 900V$ $di/dt = 990A/\mu s$		$T_j = 25^\circ\text{C}$ $T_j = 125^\circ\text{C}$	9 16	mJ
$Q_{rr}$	Reverse Recovery Charge	$I_F = 50A$ $V_R = 900V$ $di/dt = 990A/\mu s$		$T_j = 25^\circ\text{C}$ $T_j = 125^\circ\text{C}$	19 30	$\mu C$

## Thermal and package characteristics

Symbol	Characteristic	Min	Typ	Max	Unit	
$R_{thJC}$	Junction to Case	IGBT		0.40	$^\circ\text{C/W}$	
		Diode		0.70		
$V_{ISOL}$	RMS Isolation Voltage, any terminal to case $t = 1$ min, $I_{isol} < 1mA, 50/60Hz$	3500			V	
$T_j$	Operating junction temperature range	-40		150	$^\circ\text{C}$	
$T_{STG}$	Storage Temperature Range	-40		125		
$T_C$	Operating Case Temperature	-40		125		
Torque	Mounting torque	For terminals	M5	2	3.5	N.m
		To Heatsink	M6	3	5	
Wt	Package Weight			180	g	

