

**Buck chopper  
Trench IGBT® Power Module**

**$V_{CES} = 1200V$   
 $I_C = 35A @ T_c = 80^\circ C$**

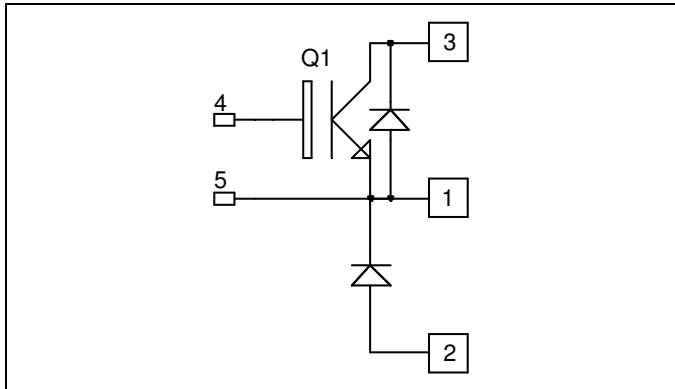

**Application**

- AC and DC motor control
- Switched Mode Power Supplies

**Features**

- Trench + Field Stop IGBT® Technology
  - Low voltage drop
  - Low tail current
  - Switching frequency up to 20 kHz
  - Soft recovery parallel diodes
  - Low diode VF
  - Low leakage current
  - Avalanche energy rated
  - RBSOA and SCSOA rated
- Kelvin emitter for easy drive
- Low stray inductance
  - M5 power connectors
- High level of integration

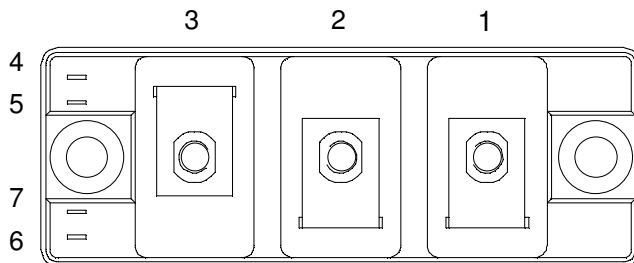

**Benefits**

- Outstanding performance at high frequency operation
- Stable temperature behavior
- Very rugged
- Direct mounting to heatsink (isolated package)
- Low junction to case thermal resistance
- Easy paralleling due to positive TC of VCEsat

**Absolute maximum ratings**

Symbol	Parameter	Max ratings	Unit
$V_{CES}$	Collector - Emitter Breakdown Voltage	1200	V
$I_C$	Continuous Collector Current	$T_C = 25^\circ C$	55
		$T_C = 80^\circ C$	35
$I_{CM}$	Pulsed Collector Current	$T_C = 25^\circ C$	70
$V_{GE}$	Gate - Emitter Voltage	$\pm 20$	V
$P_D$	Maximum Power Dissipation	$T_C = 25^\circ C$	205
RBSOA	Reverse Bias Safe Operation Area	$T_j = 125^\circ C$	70A@1200V

**CAUTION:** These Devices are sensitive to Electrostatic Discharge. Proper Handling Procedures Should Be Followed.

All ratings @  $T_j = 25^\circ\text{C}$  unless otherwise specified

## Electrical Characteristics

Symbol	Characteristic	Test Conditions	Min	Typ	Max	Unit
$BV_{CES}$	Collector - Emitter Breakdown Voltage	$V_{GE} = 0V, I_C = 1.5mA$	1200			V
$I_{CES}$	Zero Gate Voltage Collector Current	$V_{GE} = 0V, V_{CE} = 1200V$			5	mA
$V_{CE(on)}$	Collector Emitter on Voltage	$V_{GE} = 15V$ $I_C = 35A$		$T_j = 25^\circ\text{C}$ $T_j = 125^\circ\text{C}$	1.7 2.1	V
$V_{GE(th)}$	Gate Threshold Voltage	$V_{GE} = V_{CE}, I_C = 1.5mA$	5.0	5.8	6.5	V
$I_{GES}$	Gate - Emitter Leakage Current	$V_{GE} = 20V, V_{CE} = 0V$			400	nA

## Dynamic Characteristics

Symbol	Characteristic	Test Conditions	Min	Typ	Max	Unit
$C_{ies}$	Input Capacitance	$V_{GE} = 0V, V_{CE} = 25V$		2.5		nF
$C_{res}$	Reverse Transfer Capacitance	$f = 1MHz$		0.1		
$T_{d(on)}$	Turn-on Delay Time	Inductive Switching ( $25^\circ\text{C}$ ) $V_{GE} = \pm 15V$ $V_{Bus} = 600V$ $I_C = 35A$ $R_G = 27\Omega$		150		ns
$T_r$	Rise Time			90		
$T_{d(off)}$	Turn-off Delay Time			550		
$T_f$	Fall Time			130		
$T_{d(on)}$	Turn-on Delay Time	Inductive Switching ( $125^\circ\text{C}$ ) $V_{GE} = \pm 15V$ $V_{Bus} = 600V$ $I_C = 35A$ $R_G = 27\Omega$		180		ns
$T_r$	Rise Time			100		
$T_{d(off)}$	Turn-off Delay Time			650		
$T_f$	Fall Time			180		

## Reverse diode ratings and characteristics

Symbol	Characteristic	Test Conditions	Min	Typ	Max	Unit
$V_F$	Diode Forward Voltage	$I_F = 35A$ $V_{GE} = 0V$		$T_j = 25^\circ\text{C}$ $T_j = 125^\circ\text{C}$	1.6 1.6	2.1 V
$E_{rec}$	Reverse Recovery Energy	$I_F = 35A$ $V_R = 600V$ $di/dt = 990A/\mu s$		$T_j = 125^\circ\text{C}$	2.7	mJ
$Q_{rr}$	Reverse Recovery Charge	$I_F = 35A$ $V_R = 600V$ $di/dt = 990A/\mu s$		$T_j = 25^\circ\text{C}$ $T_j = 125^\circ\text{C}$	3.7 6.8	$\mu C$

## Thermal and package characteristics

Symbol	Characteristic	Min	Typ	Max	Unit	
$R_{thJC}$	Junction to Case	IGBT			0.6	$^\circ\text{C}/W$
		Diode			0.95	
$V_{ISOL}$	RMS Isolation Voltage, any terminal to case $t = 1$ min, $I_{isol} < 1mA, 50/60Hz$	2500			V	
$T_j$	Operating junction temperature range	-40		150	$^\circ\text{C}$	
$T_{STG}$	Storage Temperature Range	-40		125		
$T_C$	Operating Case Temperature	-40		125		
Torque	Mounting torque	For terminals	M5	2	3.5	N.m
		To Heatsink	M6	3	5	
Wt	Package Weight				180	g

## Package outline

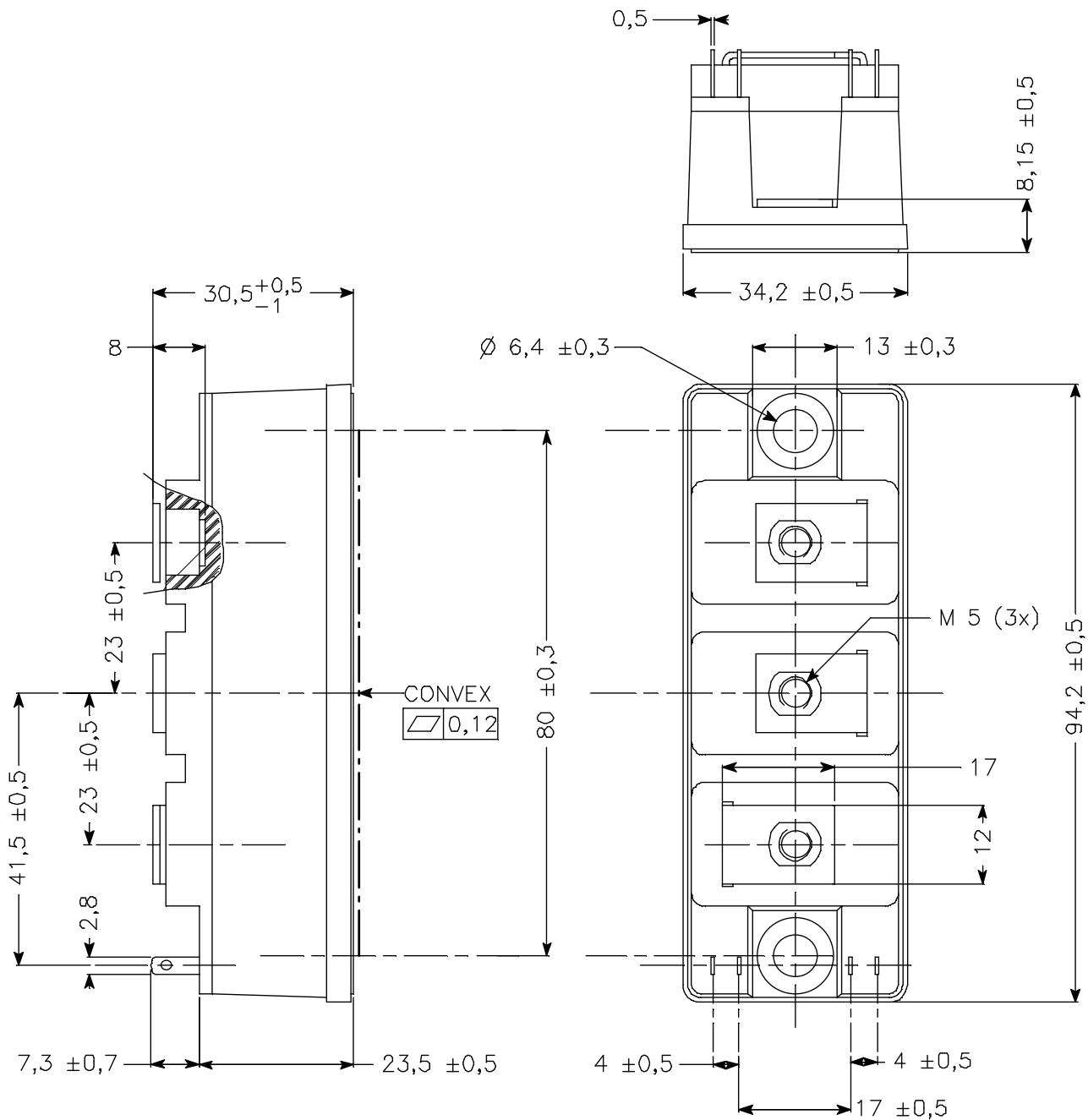

APT reserves the right to change, without notice, the specifications and information contained herein

APT's products are covered by one or more of U.S patents 4,895,810 5,045,903 5,089,434 5,182,234 5,019,522 5,262,336 6,503,786 5,256,583 4,748,103 5,283,202 5,231,474 5,434,095 5,528,058 and foreign patents. U.S and Foreign patents pending. All Rights Reserved.