

SAFETY INTERLOCK SWITCH SMALL SIZE & LIGHT FORCE

AGX (GX) SWITCHES

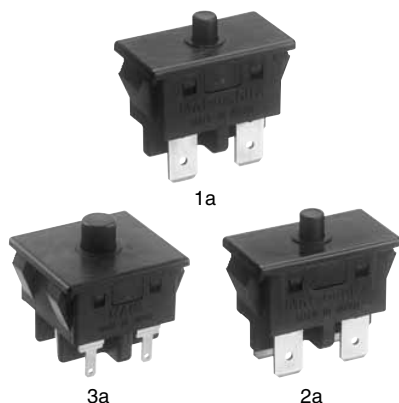

FEATURES

- Constructed with dual restoration springs and double cut-off for safety
- Contact gap of greater than 4mm (Conforming to IEC60950-1)
- As for 3 Form A type, combination of power contact and signal contact is available
- UL/C-UL/ENEC/VDE approved

TYPICAL APPLICATIONS

- Door interlock of copiers, printers, facsimiles
- Door interlock of other compact appliances

Compliance with RoHS Directive

ORDERING INFORMATION

Ex. AGX F

Product Name	Contact arrangement	Capacity and mounting method	Terminals	Contact
GX	1: 1 Form A Power switching contact 2: 2 Form A Power switching contact 3: 3 Form A Power switching contact 6: 1 Form A Power switching contact and 2 Form A Signal switching contact 7: 2 Form A Power switching contact and 1 Form A Signal switching contact	0: Standard type 10.1 A (Snap-in mounting)	5: .250 Quick-connect terminal (O.T. 2 mm) 6: .250 Quick-connect terminal (O.T. 4 mm)	F: Cadmium free

PRODUCT TYPES

Rating	Overtravel (O.T.) Min. mm	Contact arrangement	Switching timing		Part number	
			1st ON	2nd ON		
Standard type 10.1A 250V AC	2	1 Form A Power switching contact	—	—	AGX105F	
		2 Form A Power switching contact	—	—	AGX205F	
		1 Form A Power switching contact	—	—	AGX106F	
		2 Form A Power switching contact	—	—	AGX206F	
	4	3 Form A	3 Form A Power switching contact	3a power	—	AGX306F
			1 Form A Power switching contact 2 Form A Signal switching contact	1a power	2a signal	AGX606F
			2 Form A Power switching contact 1 Form A Signal switching contact	2a power	1a signal	AGX706F

SPECIFICATIONS

1. Contact rating

Number of contact	Resistive load ($\cos \phi \approx 1$)	Motor load* (EN61058-1) ($\cos \phi \approx 0.6$)
Standard type power switching contact	10.1A 125V AC 10.1A 250V AC 6A 30V DC 3A 48V DC (3 Form A type only)	3A 125V AC 3A 250V AC
Signal switching contact (3 Form A only)	0.1A 48V DC Contact Low-level circuit: 1mA 5V DC	—

Remark: Motor load designates an inrush current switching capability of 6 times the indicated rating

2. Characteristics

Type	Standard type	
Expected life	10 ⁶ min.	
Mechanical (at 60 cpm)		
Electrical (at 20 cpm, operating speed: 10mm/sec.)	10 ⁵ (at 10.1A 250V AC)	
Insulation resistance	100M Ω at 500V DC	
Dielectric strength	Between terminals	2,000Vrms for 1 minute
	Between terminals and other exposed metal parts	2,500Vrms for 1 minute
	Between terminals and ground	2,000Vrms for 1 minute
Initial contact resistance	100m Ω Max. (by voltage drop at 1A, 6 to 8V DC)	
Temperature rise (terminal portion)	Initial 45 deg. Max., After test 55 deg. Max.	
Vibration resistance	10 to 55Hz at single amplitude of 0.75mm	
Shock resistance	Min. 294m/s ²	
Actuator strength	49N for 1 minute (For operating direction)	
Tensile terminal strength	Min. 147N (Pulling for operating direction)	
Allowable operating speed	Min. 10 to 300mm/second	
Allowable operating cycle rate	60 cpm	
Temperature resistance	-40°C to -45°C: 48 hours, +80°C to +90°C: 48 hours	
Ambient temperature	-25°C to +85°C (Not freezing nor condensing)	
Flame retardancy	Min. UL 94V-1	
Tracking resistance (CTI)	Min. 175	
Contact material	AgCuO alloy	

*Remark: Test condition and judgement are complying with "JIS C4505", "EN61058" and "UL1054".

3. Operating characteristics

Contact arrangement	Part number	Operating force (O.F.) Max.	Total operating force (T.F) Max. Push button position: 2.4mm	Free position (F.P.) Max. mm	Operating position (O.P.) mm	Total travel position (T.T.P.) mm	Over travel (O.T.) Min. mm	
Standard type 10.1A 250V AC	1 Form A	AGX105F	3.92 N	4.90 N	8	4.8±0.4	2.4	2.0
	2 Form A	AGX205F	3.92 N	4.90 N	8	4.8±0.4	2.4	2.0
	1 Form A	AGX106F	3.92 N	6.86 N	10	7.0±0.4	2.4	4.0
	2 Form A	AGX206F	3.92 N	6.86 N	10	7.0±0.4	2.4	4.0
	3 Form A	AGX306F	2.94 N	5.88 N	10	7.0±0.4	2.4	4.0

Remark: With the 3 Form A type sequence operation type, the specifications for the contact where the operation position turns ON first are as per the above table. However, the specifications for the contact where the operation position turns ON later are delayed by approximately 0.8 mm compared with the above table.

CONSTRUCTION

Dual safety construction

- Dual restoration spring
- Double cut-off type

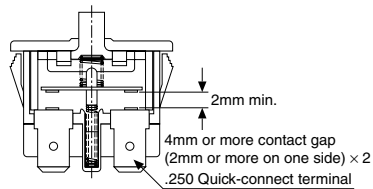

DIMENSIONS

The CAD data of the products with a **CAD Data** mark can be downloaded from: <http://panasonic-electric-works.net/ac>

mm General tolerance: ±0.4

1 Form A

CAD Data

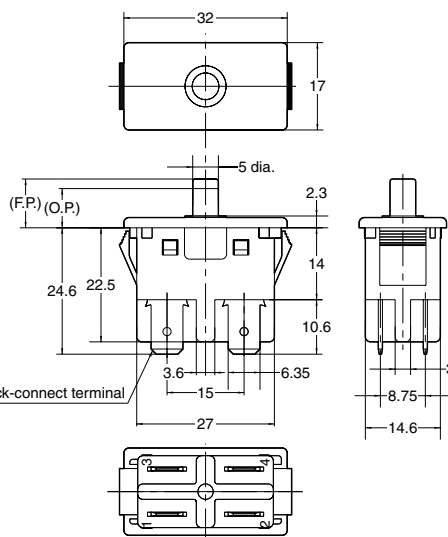

Hole cutting dimension

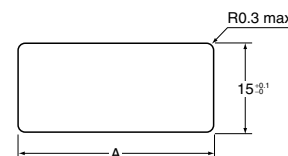

Panel thickness	1.0 to 1.75	1.75 to 2.5
Dimension A	30.2 ^{+0.1} ₋₀	30.5 ^{+0.1} ₋₀

(Copper is standard as panel material)

Remark: 1 Form A type does not have terminal No.1 nor No.2

2 Form A

CAD Data



3 Form A

CAD Data



Power switching contact



Signal switching contact

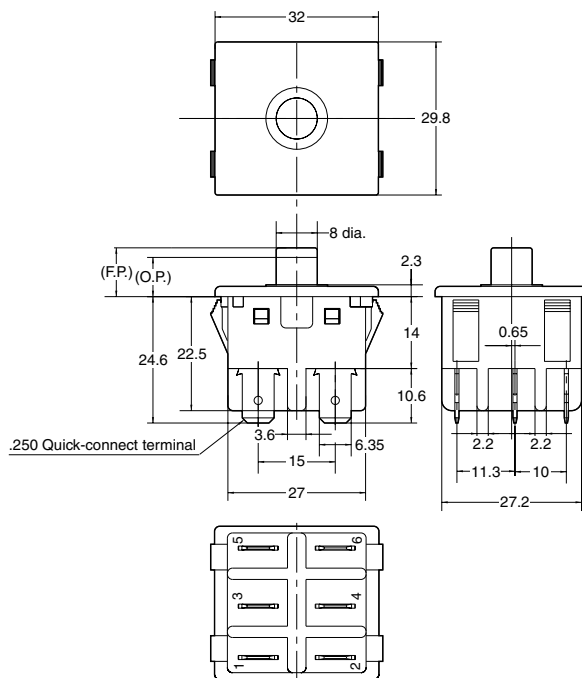

Hole cutting dimension

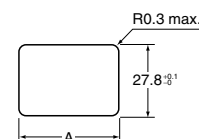

Panel thickness	0.8 to 1.75	1.75 to 2.5
Dimension A	30.2 ^{+0.1} ₋₀	30.5 ^{+0.1} ₋₀

(Copper is standard as panel material)

- Signal switching contact

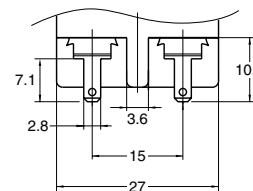

Remark: Power switching contact type has .250 Quick-connect terminal and signal switching contact type has .110 Quick-connect terminal.

NOTES

1. Switch mounting

Mount the switch with the hole cutting dimensions shown in the drawing.

2. Adjustment of the operating device:

With respect to the position of the operating device and the switch body, set the position as indicated in the condition on the right. If this condition is exceeded, the mechanical and electrical performance will be impaired. In addition, the force applied by the operating device should be in a perpendicular direction. Even if the pushbutton is used in the full total travel position, there will be no influence on the life of the switch.

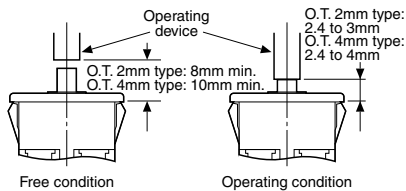

3. Confirming insulating distance

Before mounting and wiring, the insulating distance between terminals and between the terminals and ground should be checked for assurance of proper distance. With respect to the terminal connections, it is recommended that receptacles with insulating sleeves or "Positive Lock Connector*" be used. Also consideration should be given to the wiring not to apply force to the terminal section normally.

*Registered by AMP, Ltd.

4. Regarding fastening lead wires to terminals

Use .250 receptacle (terminal thickness 0.8mm) or .1110 receptacle (terminal thickness 0.5mm) should be used for connection. Make sure the sockets are straight. If they are skewed, the terminals will require excessive insertion force. The insertion force varies according to manufacturer's specifications. Check it for

the sockets you are using.

5. Material of the panel

Steel sheet is recommended as the panel material. When using soft material, confirm the condition for actual use.

6. Quality check under actual loading conditions

To improve reliability, check the switch under actual loading conditions. Avoid any situation that may adversely affect switching performance.

7. Avoid using and keeping switches in the following conditions.

- In corrosive gases
- In a dusty environment
- Where silicon atmosphere prevails

REFERENCE

1. Outline of UL1054 test

Overload test

Standard type: 12.5A 250V AC
(Power factor 0.75 to 0.8)

Endurance test

Standard type: 10A 250V AC
(Power factor 0.75 to 0.8)

After testing, temperature rise of terminals should be less than 30°C and no abnormality should be observed in characteristics.

2. Outline of EN61058-1 test

After switching 25,000 times on the above load condition at both 85⁺⁵°C and 25±10°C, temperature rise of terminals should be less than 55°C and no abnormality should be observed in characteristics.

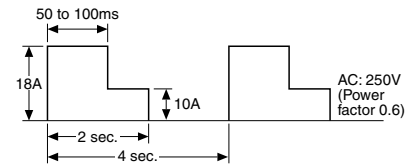

INTRODUCTION OF CONNECTORS (made by Nippon Tanshi co.,Ltd)

1. For 2 Form A power switching contact type



Applicable AGX switch part No.:
AGX205F, AGX206F

* Housing

Model number: N1620-4204

* Receptacle

Model numbers

17168-2 (for narrow wires, post-plated product)

17168-M2 (for narrow wires, wood veneer plated product)

172131-M2 (for thick wires)

2. For 2 Form A power switching contact type of 2 Form A power switching contact + 1 Form A signal switching contact



Applicable AGX switch part No.:
AGX706F

* Housing

Model number: N3220-4204

* Receptacle

Model numbers

17901-M2, 17902-M2, 17903-M3 (wire size differences)

Remark: Please consult us if you need above connectors.