

MAB series

Micro limit snap action switch

Distinctive features and specifications

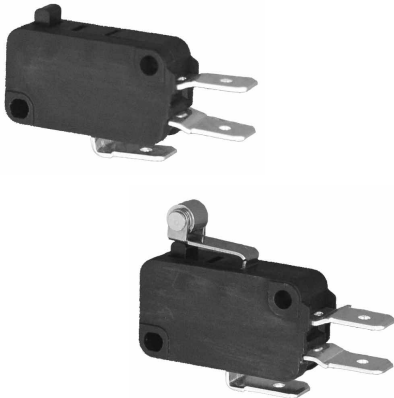

- Movement differential $\leq 0.4\text{mm}$.
- Available in normally open, normally closed and change-over functions.
- Solder lug, quick connect, PCB, and screw terminals available.

ELECTRICAL SPECIFICATIONS

- AC rating: 1(0.3)A...16(4)A, 250VAC
- Electrical life: 50,000 cycles min.

MATERIALS

- Case: PBT/PET (UL94V-0)
- Actuator: Phenolic (UL94V-0)
- Contact spring: CuBe
- Terminals: CuZn Ag plated
- Contacts: AgNi

GENERAL SPECIFICATIONS

- Operating temperature: -10°C to $+85/125^{\circ}\text{C}$
- Pretravel: $\leq 1.4\text{ mm}$
- Overtravel: 0.75mm min to 1.50mm max.
- Movement differential: $\leq 0.4\text{mm}$
- Operating position: $14.8 \pm 0.6\text{mm}$
- Contact gap: $< 3\text{mm}$

AGENCY APPROVALS



MAB series

Micro limit snap action switch

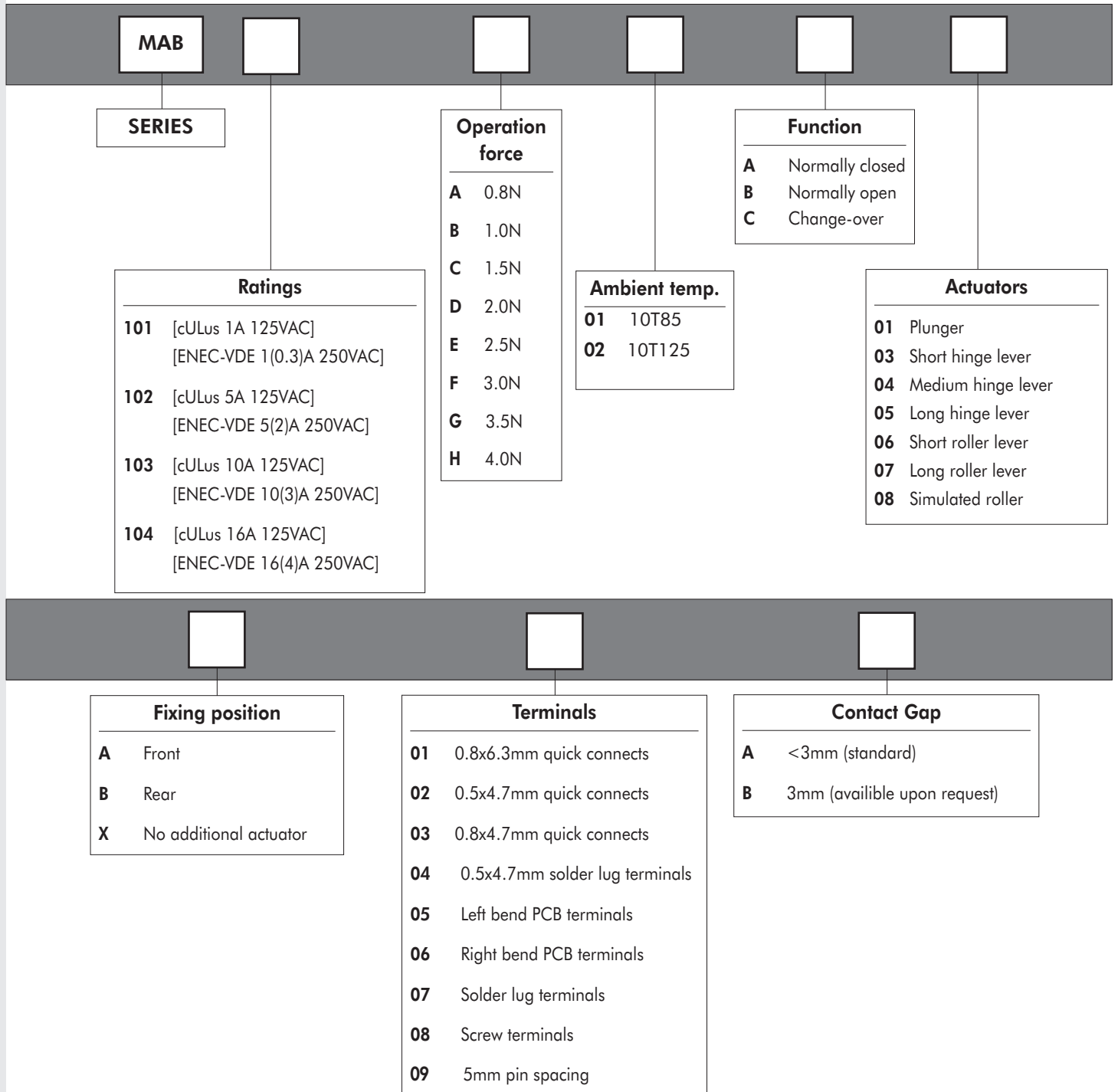

ABOUT THIS SERIES

On the following pages, you will find successively :

- model structure of switches
- options in the same order as in above chart

Dimensions : first dimensions are in mm while inches are shown as bracketed numbers.



NOTICE : please note that not all combinations of above numbers are available. Refer to the following pages for further information.

MAB series

Micro limit snap action switch

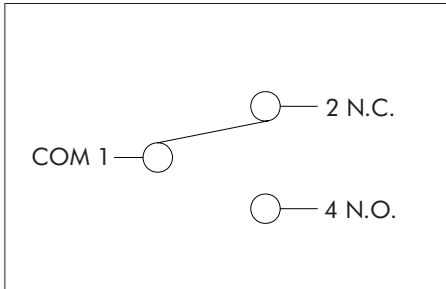

Change-over with plunger

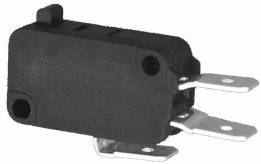

MAB C01B01

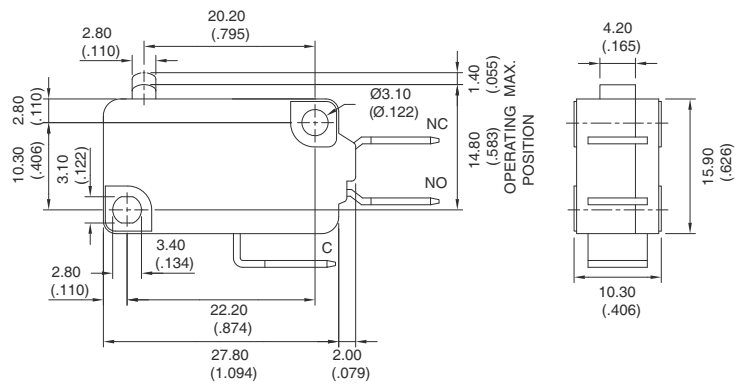

Change-over with short hinge lever

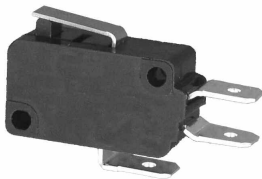

MAB C03B01

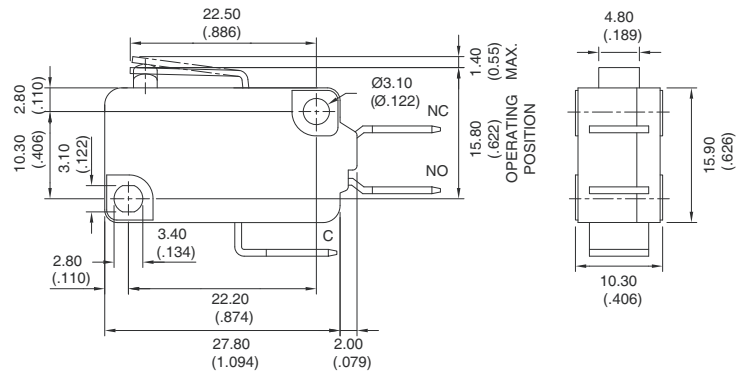

Change-over with medium hinge lever



MAB C04B01

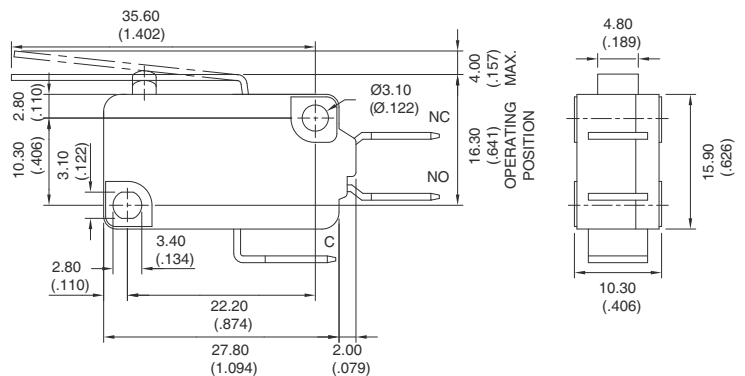

MAB series

Micro limit snap action switch

Change-over with long hinge lever

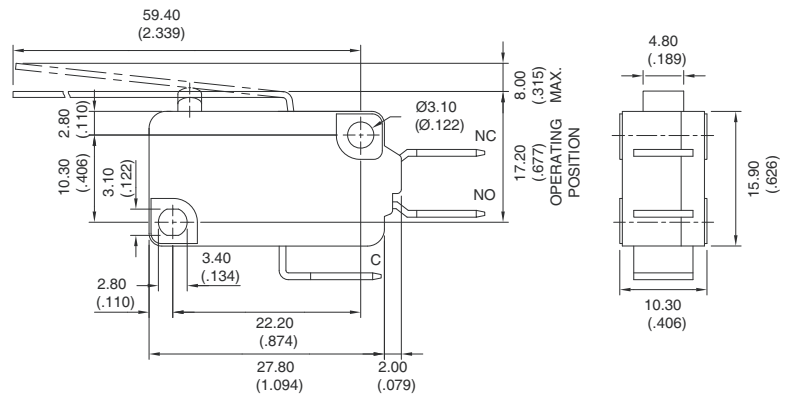
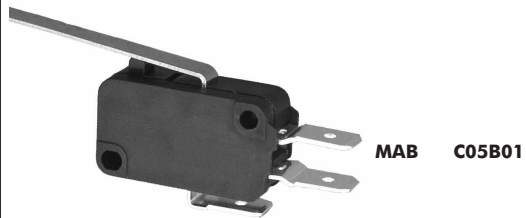

Change-over with short roller lever

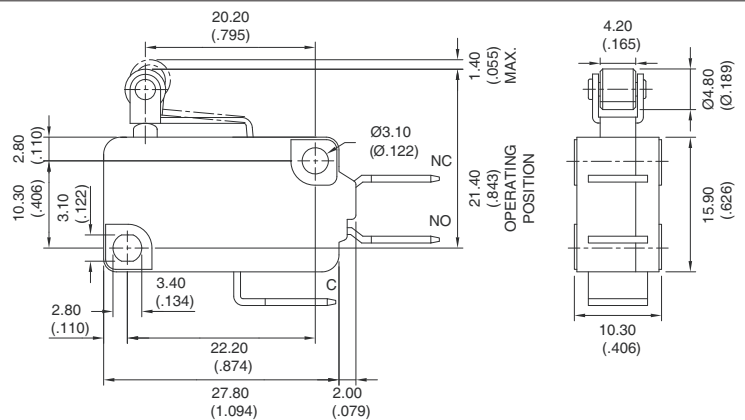
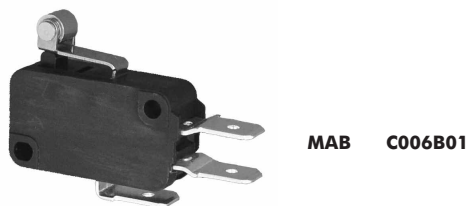

Change-over with long roller lever

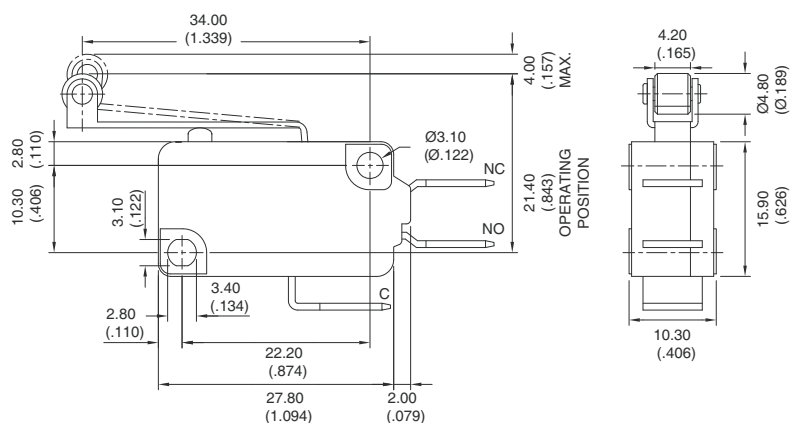

Change-over with simulated roller

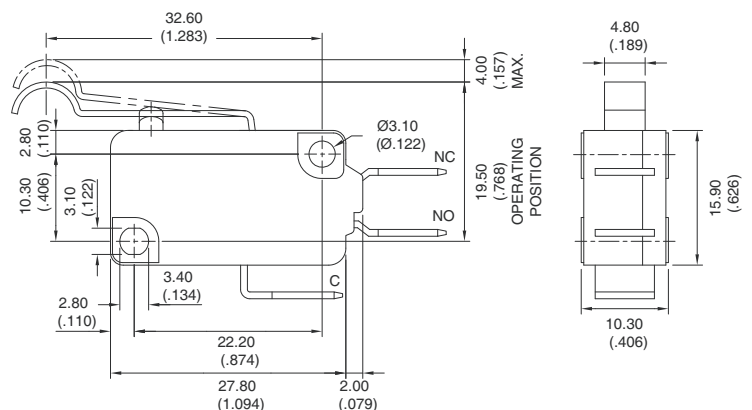
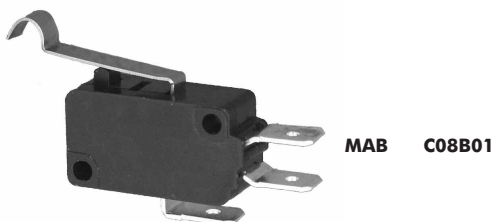

MAB series

Micro limit snap action switch

Fixing position

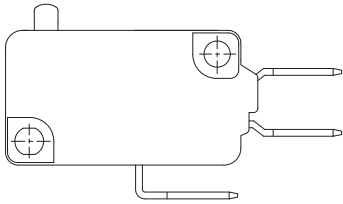

X No additional actuator

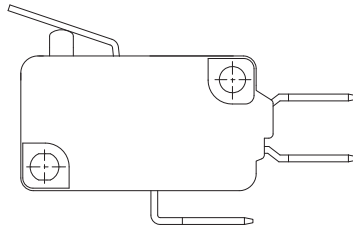

A Front

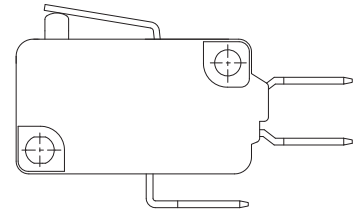

B Rear

Terminal options

01 0.8x6.3mm quick connect terminals

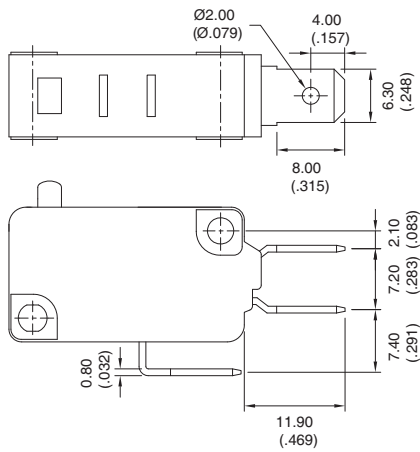

02 0.5x4.7mm quick connect terminals

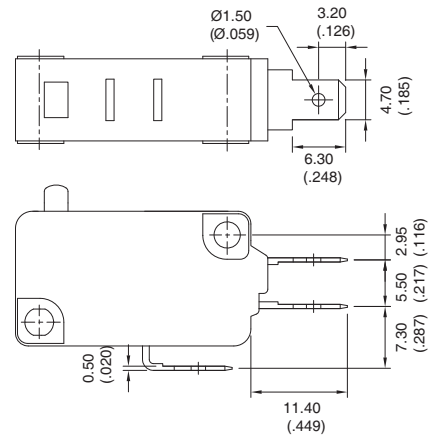

03 0.8x4.7mm quick connect terminals

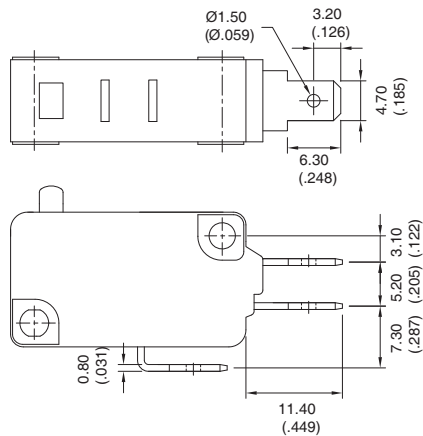

04 0.5x4.7mm solder lug terminals

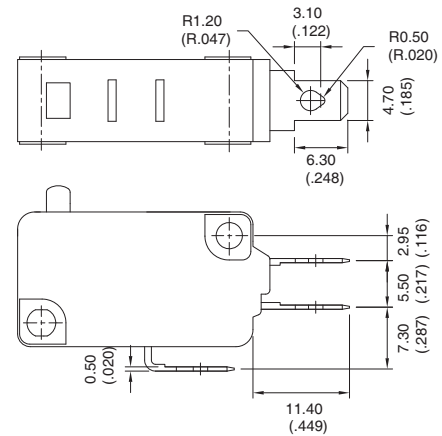

MAB series

Micro limit snap action switch

Terminal options

05 Left bend PCB terminals

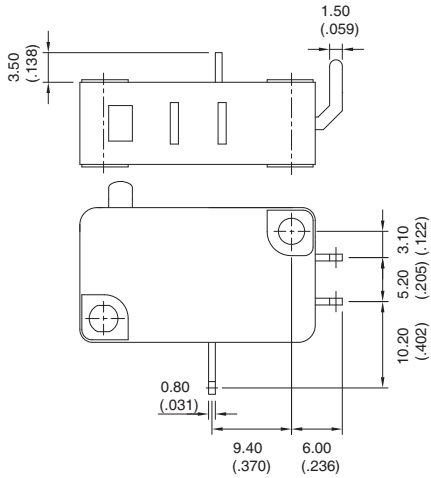

06 right bend PCB terminals

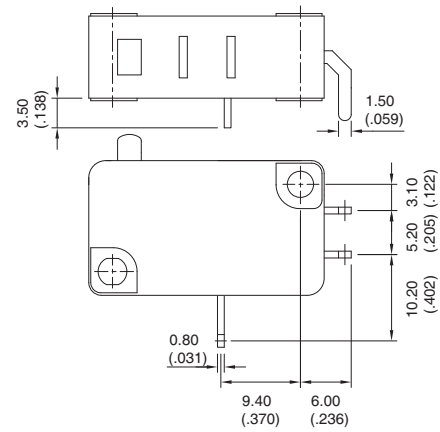

07 Solder lug terminals

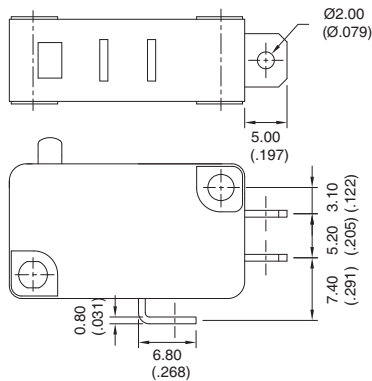

08 Screw terminals

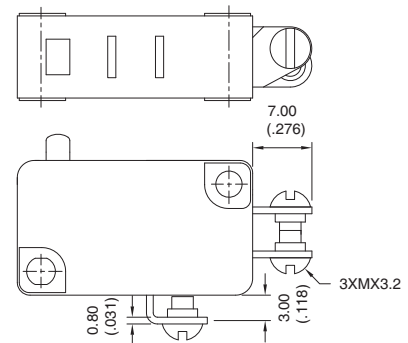

09 Solder lug with 5mm pin spacing

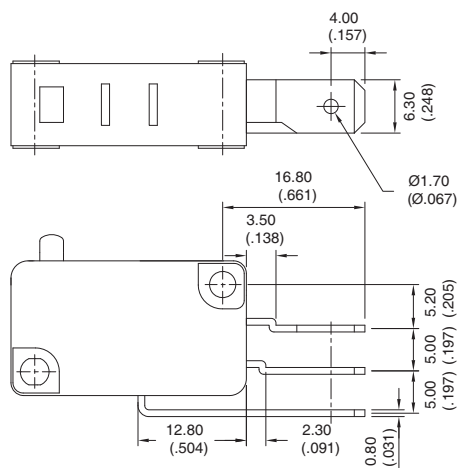

MAB series

Micro limit snap action switch

Mounting hole dimensions

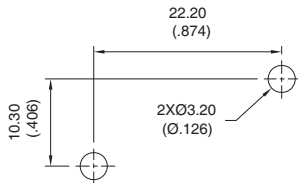

Fixing holes

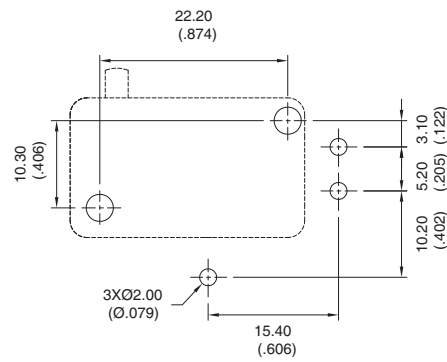

**Left bend
PCB terminals**

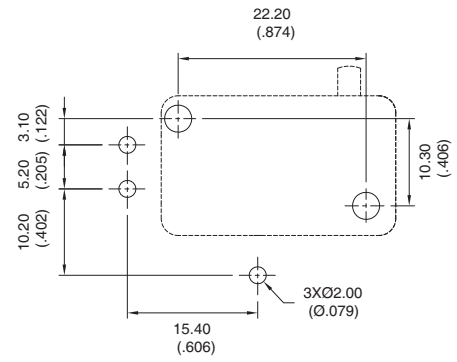

**Right bend
PCB terminals**

MAB series

Micro limit snap action switch

MAB	Actuator	Actuator length	Operation force on plunger (≤N)	Operation force on lever (≤N)	Pretravel mm (in)	Overtravel mm (in)	Movement differential mm (in)	Free position mm (in)	Operating position
Plunger	01	-	0.8	-	1.40 (.055)	0.75-1.50 (.030-.059)	0.40 (.016)	16.80 (.661)	14.80±0.60 (.583±.024)
			1.0	-					
			1.5	-					
			2.0	-					
			2.5	-					
			3.0	-					
			3.5	-					
4.0	-								
Rear fixing position									
Short hinge lever	03	22.50 (.886)	0.8	0.80	1.40 (.055)	1.00 (.039)	0.50 (.020)	17.70 (.697)	15.80±0.50 (.622±.020)
			1.0	1.00					
			1.5	1.50					
			2.0	2.00					
			2.5	2.50					
			3.0	3.00					
			3.5	3.50					
4.0	4.00								
Medium hinge lever	04	35.60 (1.402)	0.8	0.36	4.00 (.157)	2.00 (.079)	1.00 (.039)	21.50 (.847)	16.30±0.50 (.642±.020)
			1.0	0.45					
			1.5	0.70					
			2.0	0.90					
			2.5	1.15					
			3.0	1.30					
			3.5	1.60					
4.0	1.80								
Long hinge lever	05	59.40 (2.339)	0.8	0.20	8.00 (.315)	4.00 (.157)	0.20 (.079)	27.70 (1.091)	17.20±2.50 (.677±.098)
			1.0	0.25					
			1.5	0.37					
			2.0	0.50					
			2.5	0.62					
			3.0	0.75					
			3.5	0.88					
4.0	1.00								
Short roller lever	06	20.20 (.795)	0.8	0.90	1.40 (.055)	1.00 (.039)	0.40 (.016)	23.40 (.921)	21.40±0.60 (.843±.024)
			1.0	1.10					
			1.5	1.60					
			2.0	2.20					
			2.5	2.66					
			3.0	3.20					
			3.5	3.72					
4.0	4.25								
Long roller lever	07	34.00 (1.339)	0.8	0.40	4.00 (.157)	2.00 (.079)	1.00 (.039)	26.60 (1.047)	21.40±1.20 (.843±.047)
			1.0	0.50					
			1.5	0.80					
			2.0	1.00					
			2.5	1.30					
			3.0	1.60					
			3.5	1.87					
4.0	2.14								
Simulated roller lever	08	32.60 (1.283)	0.8	0.43	4.00 (.157)	2.00 (.079)	1.00 (.039)	24.70 (.972)	19.50±1.20 (.768±.047)
			1.0	0.54					
			1.5	0.81					
			2.0	1.08					
			2.5	1.35					
			3.0	1.62					
			3.5	1.89					
4.0	2.16								

MAB series

Micro limit snap action switch

Front fixing position									
MAB	Actuator	Actuator length	Operation force on plunger ($\leq N$)	Operation force on lever ($\leq N$)	Pretravel mm (in)	Overtravel mm (in)	Movement differential mm (in)	Free position mm (in)	Operating position
Short hinge lever	03	28.20 (1.110)	0.8	0.65	3.20 (.126)	1.50 (.059)	0.80 (.031)	19.70 (.776)	16.40±1.00 (.646±.03)
			1.0	0.79					
			1.5	1.20					
			2.0	1.60					
			2.5	2.00					
			3.0	2.40					
			3.5	2.80					
4.0	3.20								
Medium hinge lever	04	41.20 (1.622)	0.8	0.45	6.20 (.244)	3.00 (.118)	1.20 (.047)	25.50 (1.004)	17.80±1.50 (.701±.059)
			1.0	0.54					
			1.5	0.85					
			2.0	1.10					
			2.5	1.38					
			3.0	1.70					
			3.5	1.95					
4.0	2.20								
Long hinge lever	05	64.90 (2.555)	0.8	0.28	11.70 (.461)	4.50 (.177)	2.00 (.079)	34.70 (1.366)	20.50±2.50 (.807±.098)
			1.0	0.35					
			1.5	0.52					
			2.0	0.70					
			2.5	0.87					
			3.0	1.05					
			3.5	1.22					
4.0	1.40								
Short roller lever	06	25.60 (1.008)	0.8	0.69	2.40 (.094)	1.50 (.059)	0.80 (.031)	25.50 (1.004)	22.50±0.60 (.886±.024)
			1.0	0.87					
			1.5	1.30					
			2.0	1.74					
			2.5	2.17					
			3.0	2.60					
			3.5	3.00					
4.0	3.48								
Long roller lever	07	39.40 (1.551)	0.8	0.45	5.60 (.197)	2.50 (.098)	1.20 (.047)	30.80 (1.213)	24.00±1.20 (.945±.047)
			1.0	0.56					
			1.5	0.84					
			2.0	1.12					
			2.5	1.40					
			3.0	1.68					
			3.5	1.95					
4.0	2.25								
Simulated roller lever	08	38.20 (1.504)	0.8	0.47	5.60 (.197)	2.50 (.098)	1.20 (.047)	27.60 (1.087)	20.80±1.20 (.819±.047)
			1.0	0.59					
			1.5	0.88					
			2.0	1.18					
			2.5	1.47					
			3.0	1.76					
			3.5	2.06					
4.0	2.35								