

O.P. (MM)	P.T. (MM)
20.7 ± 1.5	5.5 MAX.

O.P. = OPERATING POINT
P.T. = PRE-TRAVEL

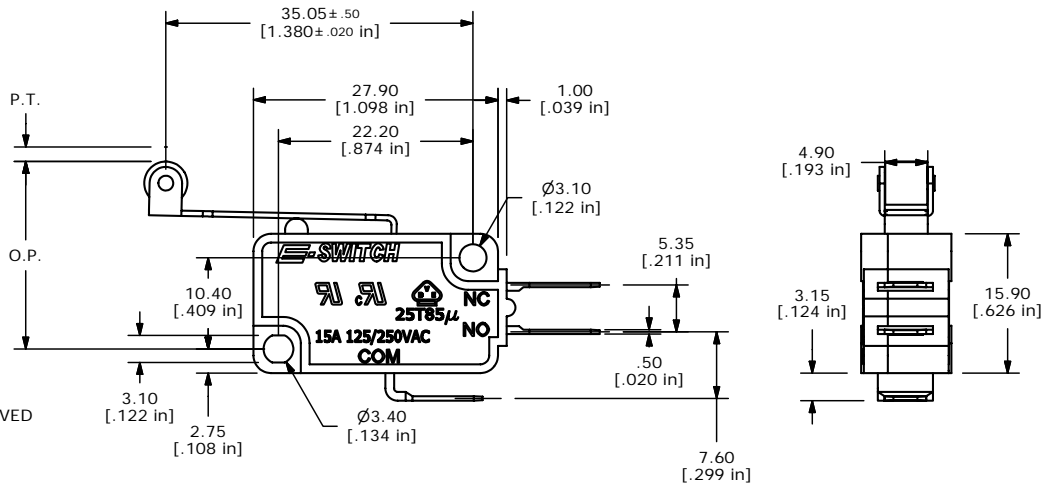
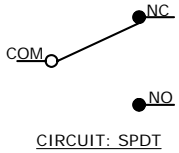

- NOTES:
1. ALL DIMENSIONS IN MM [INCH]
 2. GENERAL TOLERANCE: X.X=±0.4
X.XX=±0.25
 3. RATING: 15A @125/250VAC UL, CUL, VDE APPROVED
 4. OPERATING FORCE: 120±40 GRAMS
 5. OPERATING TEMP: -25°C TO 85°C
 6. ELECTRICAL LIFE: 50,000 CYCLES MIN.
 7. MECHANICAL LIFE: 1,000,000 CYCLES TYP.
 8. INSULATION RESISTANCE: 100 MEGA-OHMS MIN.
 9. DIELECTRIC STRENGTH: 1500VAC 1 MINUTE (INITIAL VALUE)
 10. CONTACT RESISTANCE: 100 MILLI -OHMS MAX.
 11. ▲ DENOTES CRITICAL PARAMETER.
 12. 2002/95/EC (ROHS) COMPLIANT

E-SWITCH®

B	15807	EDIT OPERATING POINT, FORCE NOTE	2/22/06	PH
A	15728	RELEASED FOR PRODUCTION	2/6/06	PH
REV	PCR NO	DESCRIPTION	DATE	BY

TITLE LS0851506F120C1A				
SCALE	DATE	DR	DWG	REV
1.5:1	2/6/2006	PH	Q950032	B

THE INFORMATION CONTAINED IN THIS DOCUMENT IS PROPRIETARY TO E-SWITCH AND IS NOT TO BE COPIED OR TRANSFERRED