

ISOMETRIC

B	O.P. (MM)	P.T. (MM)
	8.5 ±0.3	1.1 MAX

O.P. = OPERATING POINT  
P.T. = PRE-TRAVEL

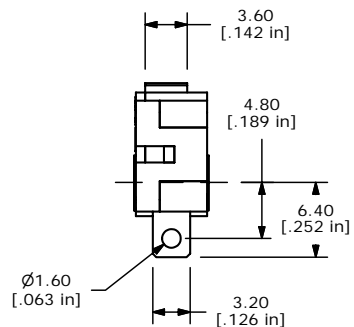
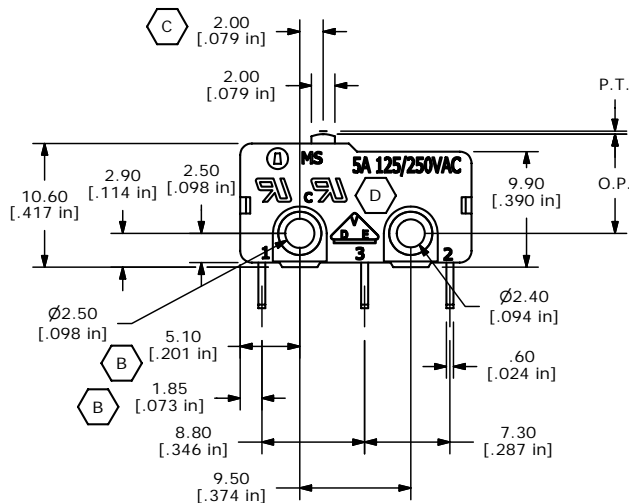
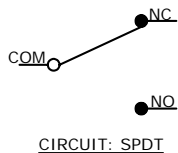

- NOTES:
1. ALL DIMENSIONS IN MM [INCH]
  2. GENERAL TOLERANCE: X.X=±0.4  
X.XX=±0.25
  3. RATING: 5A @125/250VAC UL, CUL, VDE APPROVED
  - ▲ 4. OPERATING FORCE: 080±25 GRAMS
  5. OPERATING TEMP: -25°C TO 85°C
  6. ELECTRICAL LIFE: 50,000 CYCLES MIN.
  7. MECHANICAL LIFE: 1,000,000 CYCLES TYP.
  8. INSULATION RESISTANCE: 100 MEGA-OHMS
  9. DIELECTRIC STRENGTH: 1000VAC 1 MINUTE (INITIAL VALUE)
  10. CONTACT RESISTANCE: 100 MILLI-OHMS MAX.
  11. ▲ DENOTES CRITICAL PARAMETER.
  12. 2002/95/EC (ROHS) COMPLIANT

REV	PCR NO	DESCRIPTION	DATE	BY
D	15642	CHANGES NOTED	12/28/05	PH
C	14969	CHANGED DIMENSION	6/1/05	JB
B	14888	CHANGED NOTES AND DIMENSIONS	4/29/05	JB
A	14692	RELEASED FOR PRODUCTION	2/15/05	AR

**E-SWITCH®**

TITLE MS0850500F080S1A

SCALE	DATE	DR	DWG	REV
2:1	2/7/2005	AR	Q970001	D

THE INFORMATION CONTAINED IN THIS DOCUMENT IS PROPRIETARY TO E-SWITCH AND IS NOT TO BE COPIED OR TRANSFERRED