

CONTACT CONFIGURATION  
TIMING (BBM) NON-SHORTING

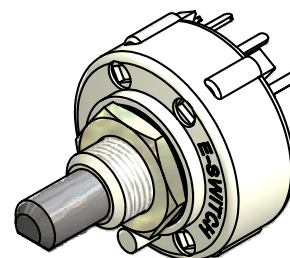

ISOMETRIC

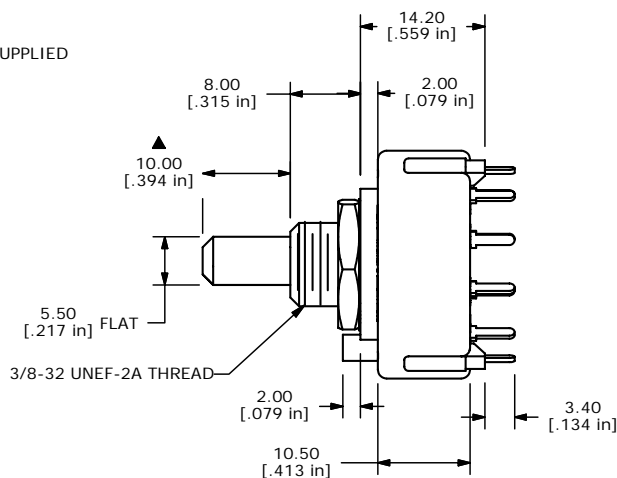
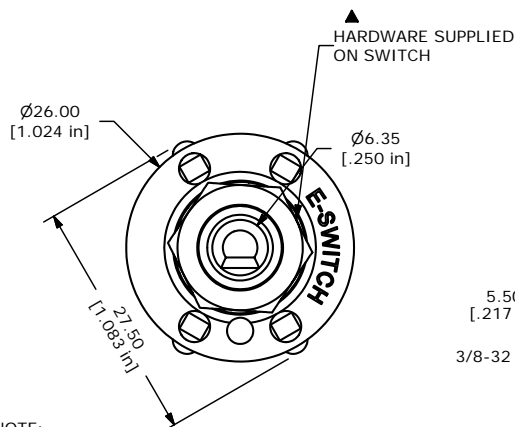
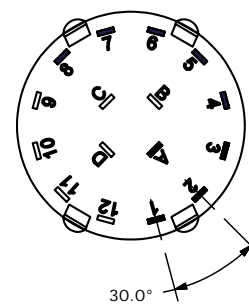

- NOTE:
1. ALL DIMENSIONS IN MM [INCH].
  2. GENERAL TOLERANCE: X.X=±0.4  
X.XX=±0.25
  3. TERM. NOS. FOR REFERENCE ONLY.
  - ▲ 4. CONTACT MATERIAL: GOLD
  5. CONTACT RATING: 0.3A @ 125VAC
  6. OPERATING FORCE 800±300CM/STANDARD
  7. OPERATING TEMP: -30°C TO 85°C
  - ▲ 8. CIRCUIT SP: 8 POSITION 30° INDEX.
  9. DIELECTRIC STRENGTH: 500 VAC FOR 1 min..
  - ▲ 10. HARDWARE SUPPLIED ON SWITCH:  
LOCKWASHER, HEXNUT, STOP RING
  11. ▲ DENOTES CRITICAL PARAMETER.
  12. 2002/95/EC (ROHS) COMPLIANT.

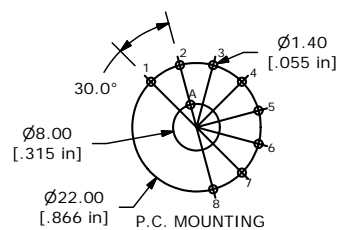

**E-SWITCH®**

TITLE KC18A10.001NPF

A	16276	RELEASED FOR PRODUCTION	8/3/06	BO
REV	PCR NO	DESCRIPTION	DATE	BY

THE INFORMATION CONTAINED IN THIS DOCUMENT IS PROPRIETARY TO E-SWITCH AND IS NOT TO BE COPIED OR TRANSFERRED

SCALE	DATE	DR	DWG	REV
1.5:1	8/3/2006	BO	G530108	A