

NOTES:

1. ALL DIMENSION IN MM [INCH]
2. GENERAL TOLERANCE: X,X=±0.4
X:XX=±0.25
3. TERM. NOS. FOR REF. ONLY
4. CONTACT RATING SWITCHING: 150mA, 250V AC/DC
350mA, 110V AC/DC
5. CONTACT RATING (NON-SWITCHING): 5A
6. OPERATING FORCE: 425±100 CM/STANDARD
7. CONTACT MATERIAL: GOLD FLASH OVER SILVER PLATE
over COPPER ALLOY
8. OPERATING TEMP: -30° to 85°C
9. CIRCUIT SP: 6 POSITIONS, 30° INDEX.
10. DIELECTRIC STRENGTH: 1000V RMS min @SEA LEVEL.
11. SHARDWARE SUPPLIED ON SWITCH - SEE BELOW
STOP RING, LOCKWASHER, & HEXNUT
12. ▲ DENOTES CRITICAL PARAMETER

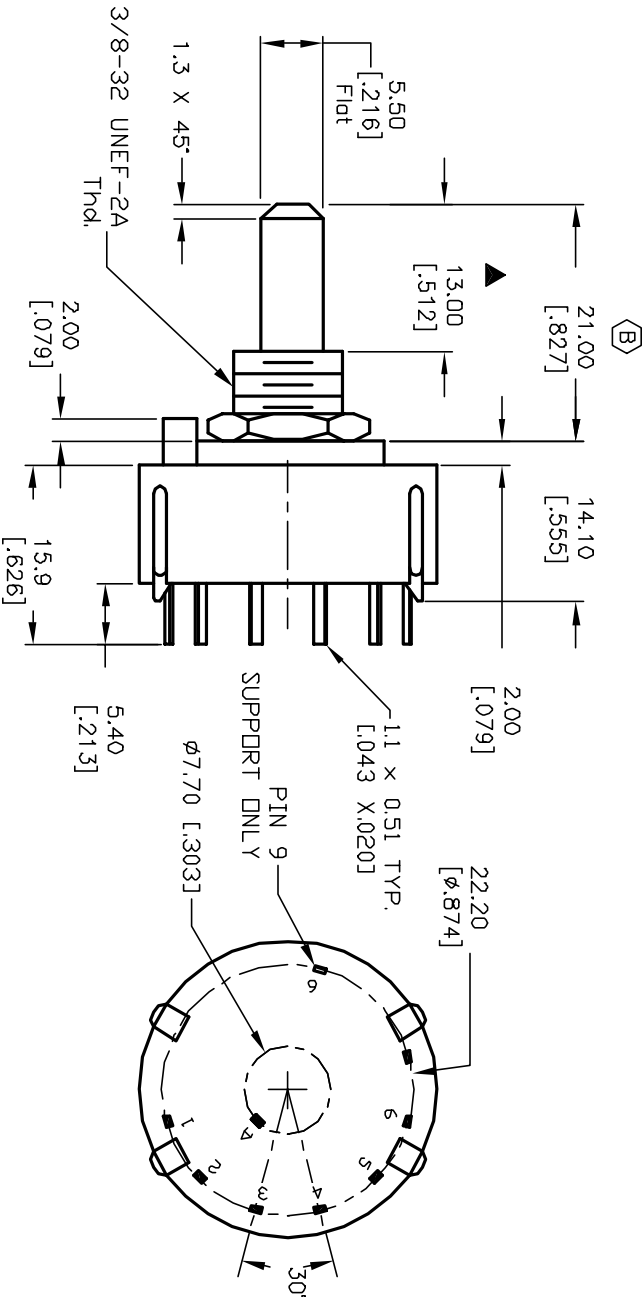
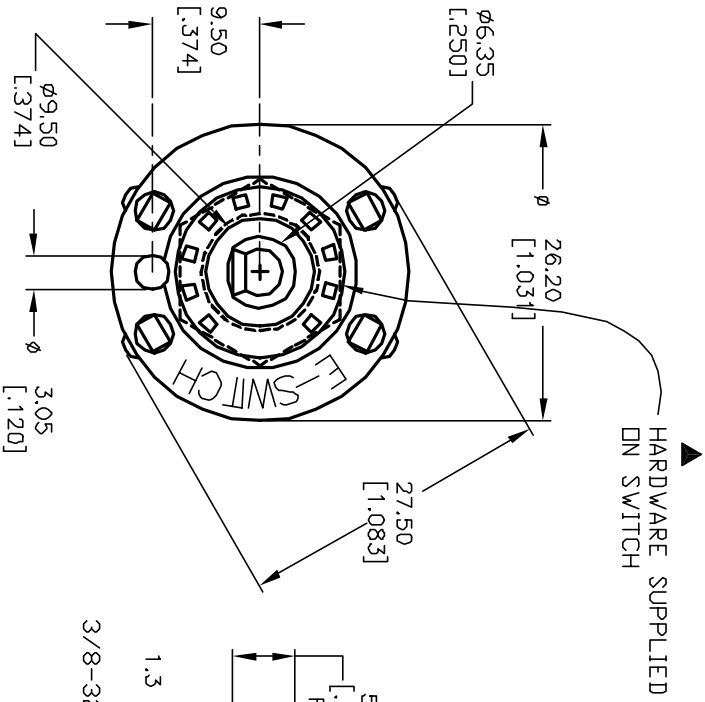
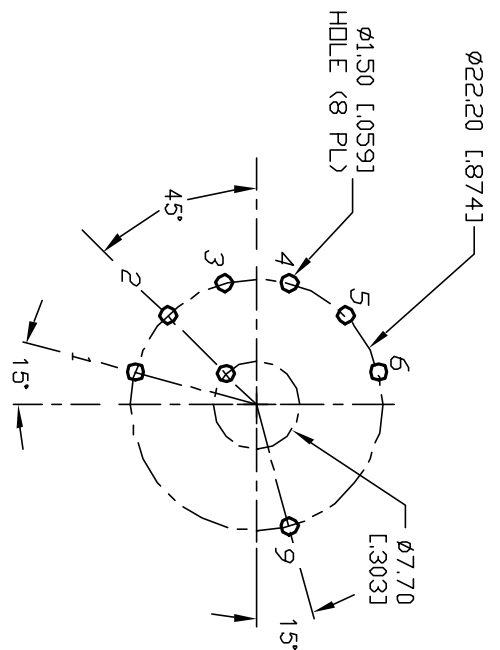
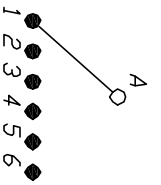

B	13172	21.00 WAS 38.00	6/2/03	AR
A	13164	RELEASED FOR PRODUCTION	5/28/03	AR
REV.	ECN No.	DESCRIPTION	DATE	CHKD

TITLE		SCALE	DATE	DR	DWG	REV
KC16A13.001NPF		1.5:1	5/28/03	AR	G510711	B

E-SWITCH®

THE INFORMATION CONTAINED IN THIS DOCUMENT IS PROPRIETARY TO E-SWITCH AND IS NOT TO BE COPIED OR TRANSFERRED