

ISOMETRIC

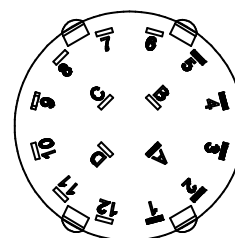
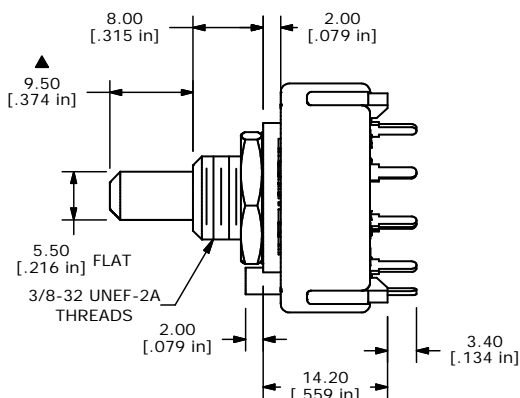
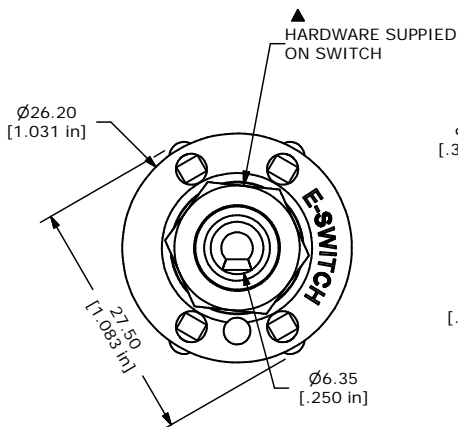

NOTE:

1. ALL DIMENSIONS IN MM [INCH].
2. GENERAL TOLERANCE: X.X=±0.4  
X.XX=±0.25
3. TERM. NOS. FOR REFERENCE ONLY.
4. CONTACT MATERIAL: GOLD FLASH
5. CONTACT RATING: 150MILLIAMP, 250VAC/DC  
350MILLIAMP, 110VAC/DC
6. CONTACT RATING (NON-SWITCHING) 5A
7. OPERATING FORCE 425±100CM/STANDARD
8. OPERATING TEMP: -30°C TO 85°C
- ▲ 9. CIRCUIT SP: 5 POSITION 30° INDEX.
10. DIELECTRIC STRENGTH: 1000V RMS MIN.@ SEA LEVEL.
- ▲ 11. HARDWARE SUPPLIED ON SWITCH:  
STOP RING, LOCKWASHER, HEXNUT
12. ▲ DENOTES CRITICAL PARAMETER.

**E-SWITCH®**

TITLE KC15A9.501NPF

A	14282	RELEASED FOR PRODUCTION	9/1/04	AR
REV	PCR NO	DESCRIPTION	DATE	BY

THE INFORMATION CONTAINED IN THIS DOCUMENT IS PROPRIETARY TO E-SWITCH AND IS NOT TO BE COPIED OR TRANSFERRED

SCALE	DATE	DR	DWG	REV
1.5:1	9/1/04	AR	G510602	A