

CONTACT CONFIGURATION
TIMING (BBM) NON-SHORTING

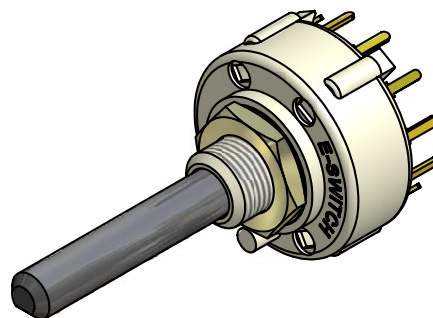

ISOMETRIC

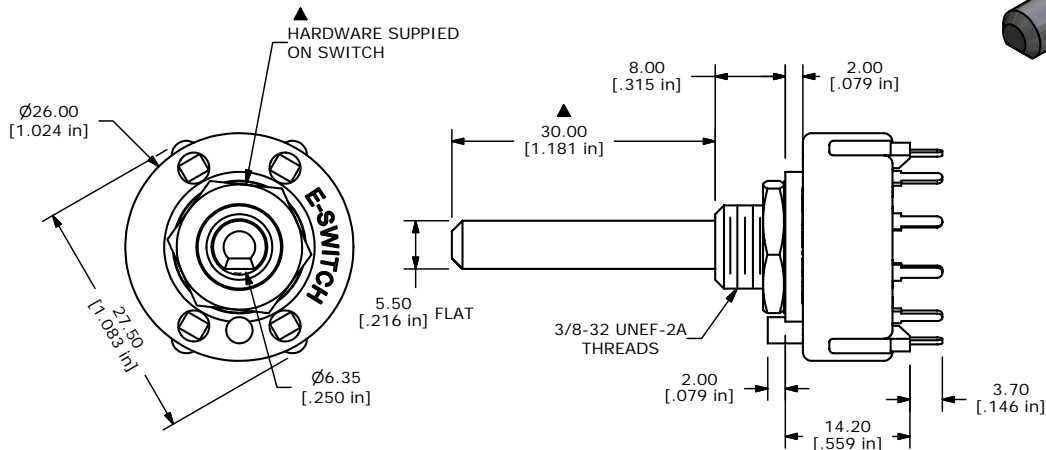
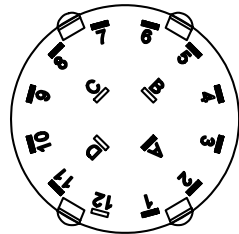

- NOTE:
1. ALL DIMENSIONS IN MM[INCH].
 2. GENERAL TOLERANCE: ± 0.4
 3. TERM. NOS. FOR REFERENCE ONLY.
 4. CONTACT MATERIAL: SILVER
 5. CONTACT RATING: 0.3A @ 125VAC
 6. OPERATING FORCE 800 \pm 300 GRAMS-CM
 7. OPERATING TEMP: -30°C TO 85°C
 - ▲ 8. CIRCUIT SP: 11 POSITION 30° INDEX.
 9. DIELECTRIC STRENGTH: 500 VAC FOR 1 MINUTE
 - ▲ 10. HARDWARE SUPPLIED ON SWITCH:
STOP RING, LOCKWASHER, HEXNUT
 11. ▲ DENOTES CRITICAL PARAMETER.

E-SWITCH®

TITLE KC51A30.001NPS				
SCALE	DATE	DR	DWG	REV
1.5:1	8/12/2005	PV	G510604	A

THE INFORMATION CONTAINED IN THIS DOCUMENT IS PROPRIETARY TO E-SWITCH AND IS NOT TO BE COPIED OR TRANSFERRED