

CONTACT CONFIGURATION
TIMING (BBM) NON-SHORTING

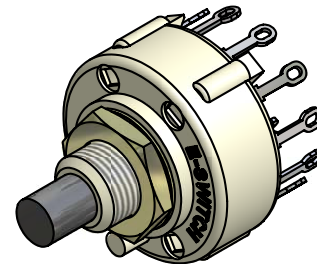

ISOMETRIC

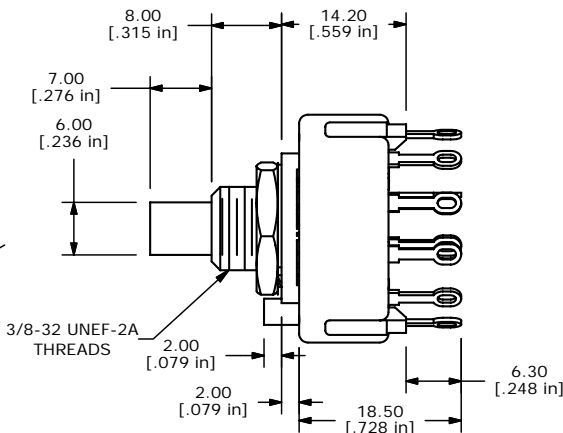
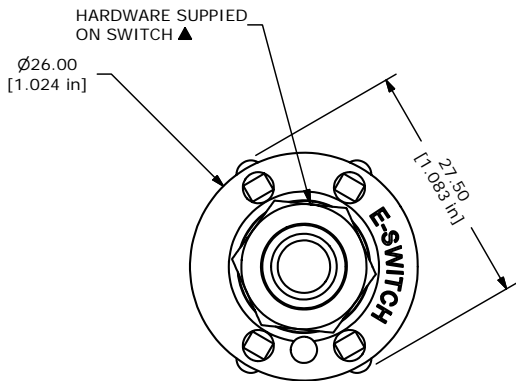
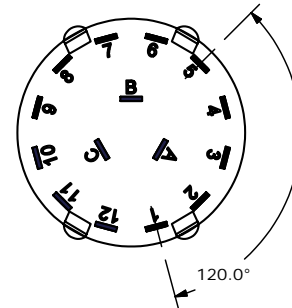

NOTE:

1. ALL DIMENSIONS IN MM[INCH].
2. GENERAL TOLERANCE: X.X±0.4
X.XX±0.25
- ▲ 3. TERM. NOS. FOR REFERENCE ONLY.
4. CONTACT MATERIAL: SILVER
5. CONTACT RATING: 0.3A @ 125VAC
6. OPERATING FORCE 800±300gm-cm
7. OPERATING TEMP: -30°C TO 85°C
- ▲ 8. CIRCUIT 3P: 4 POSITION 30° INDEX.
9. DIELECTRIC STRENGTH: 500VAC FOR 1 MIN.
- ▲ 10. HARDWARE SUPPLIED ON SWITCH:
LOCKWASHER, HEXNUT, STOP RING
11. 2002/95/EC (ROHS) COMPLIANT
12. ▲ DENOTES CRITICAL PARAMETER.

E-SWITCH®

TITLE KC34B7.001NLS

A	15436	RELEASED FOR PRODUCTION	10/24/05	PH
REV	PCR NO	DESCRIPTION	DATE	BY

THE INFORMATION CONTAINED IN THIS DOCUMENT IS PROPRIETARY TO E-SWITCH AND IS NOT TO BE COPIED OR TRANSFERRED

SCALE	DATE	DR	DWG	REV
1.5:1	10/24/2005	PH	G510589	A