

NOTES:

1. ALL DIMENSION IN MM [INCH]
2. GENERAL TOLERANCE: X.X=±0.4
X.XX=±0.25
3. TERM. NOS. FOR REF. ONLY
4. CONTACT RATING SWITCHING: 150mA, 250V AC/DC
350mA, 110V AC/DC
5. OPERATING FORCE: 425±100 CM/STANDARD
6. OPERATING TEMP: -30° to 85°C
7. CIRCUIT 3P: 4 POSITIONS, 30° INDEX.
8. DIELECTRIC STRENGTH: 1000V RMS min. @Sec Level
9. HARDWARE SUPPLIED ON SWITCH- SEE BELOW
LOCKRING, LOCKWASHER, & HEX NUT.
10. ▲ DENOTES CRITICAL PARAMETER.

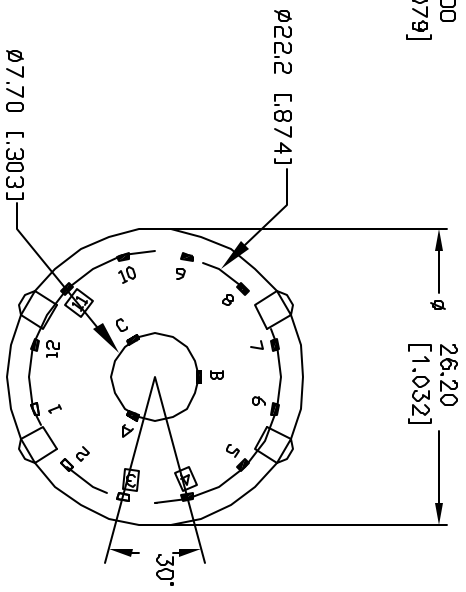
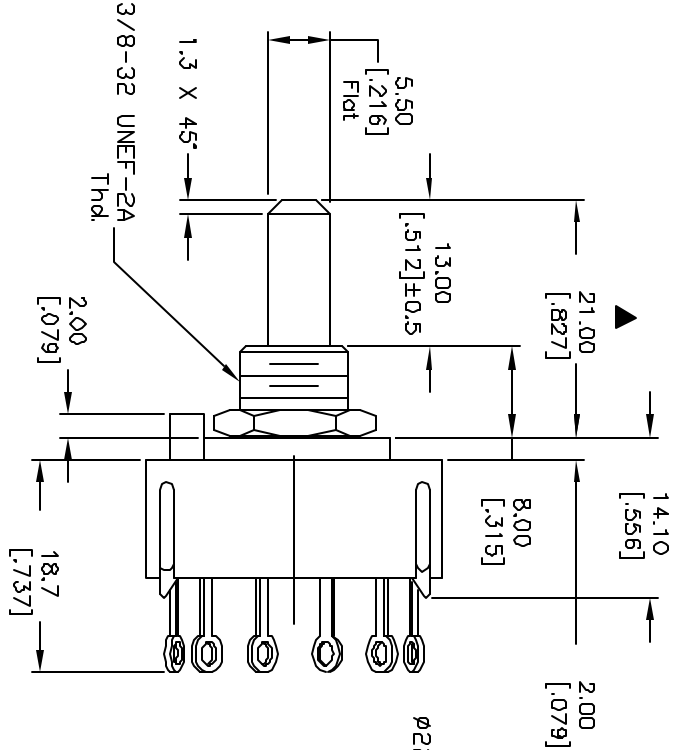
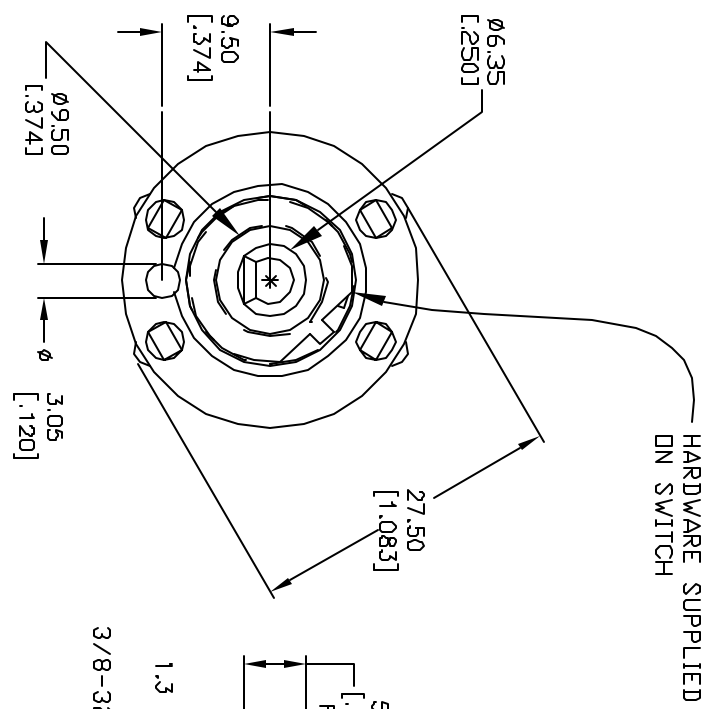
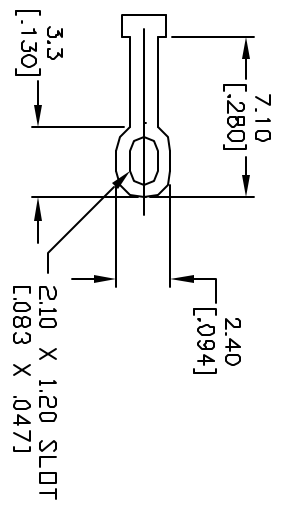
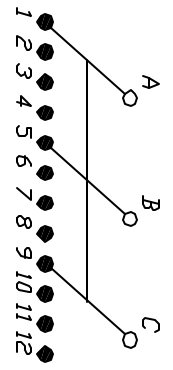

NOTES:

1. ALL DIMENSIONS IN MM
2. GENERAL TOLERANCE: X.X=±0.4
X.XX=±0.25
3. TERM. NOS. FOR REFERENCE ONLY.



A		13330	RELEASED FOR PRODUCTION	6/24/03	AR	TITLE		KC34A13.001NLS	
REV.		ECN No.	DESCRIPTION	DATE	CHKD	SCALE	DATE	DR	DWG
						1.5:1	6/24/03	AR	G510465
THE INFORMATION CONTAINED IN THIS DOCUMENT IS PROPRIETARY TO E-SWITCH AND IS NOT TO BE COPIED OR TRANSFERRED									
									REV
									A