

SHEET OF

NOTES:

1. ALL DIMENSION IN MM [INCH]
2. GENERAL TOLERANCE: X.X=±0.4
X.XX=±0.25
3. TERM. NOS. FOR REF. ONLY.
4. CONTACT RATING SWITCHING: 150mA, 250V AC/DC
350mA, 110V AC/DC
5. CONTACT RATING (NON-SWITCHING) 5A
6. CONTACT MATERIAL: SILVER OVER COPPER ALLOY
7. OPERATING FORCE: 425±100 CM/STANDARD
8. OPERATING TEMP: -30° to 85°C
- ▲ 9. CIRCUIT 3P: 3 POSITIONS, 30° INDEX. (B)
10. TIMING: BBM (Non-Shorting) Break Before Make
11. DIELECTRIC STRENGTH 1000V RMS min. @ SEA LEVEL
12. ▲ DENOTES CRITICAL PARAMETER
- ▲ 13. HARDWARE SUPPLIED ON SWITCH- SEE BELOW
STOPRING, LOCKWASHER, & HEXNUT

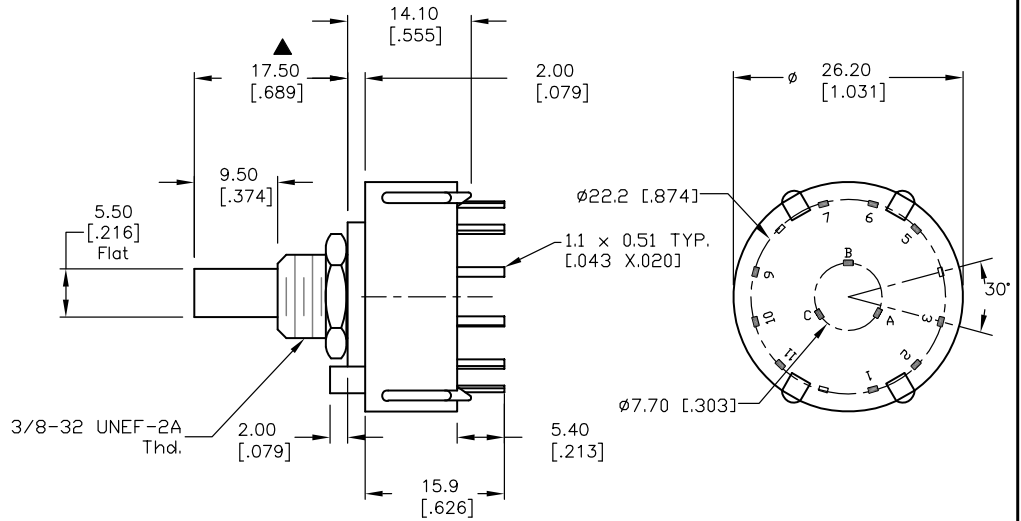
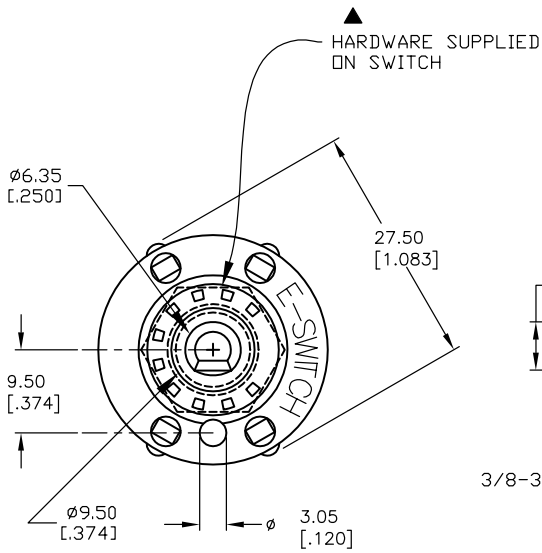
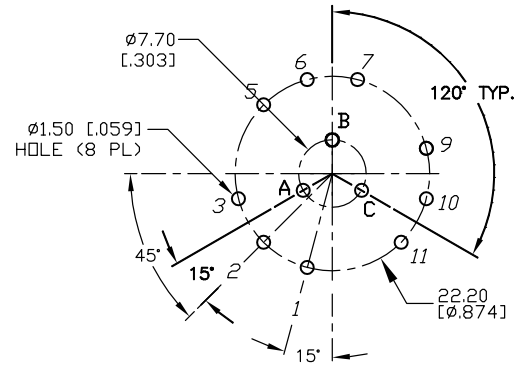
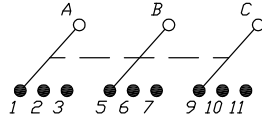

E-SWITCH®

B	12430	CORRECT NOTE 9	9/5/03	AR
A	13420	RELEASED FOR PRODUCTION	9/3/03	AR
REV.	ECN No.	DESCRIPTION	DATE	CHKD

TITLE				
KC33A9.501NPS				
SCALE	DATE	DR	DWG	REV
1.5:1	9/3/03	AR	G510259	B

THE INFORMATION CONTAINED IN THIS DOCUMENT IS PROPRIETARY TO E-SWITCH AND IS NOT TO BE COPIED OR TRANSFERRED