

- NOTES:
1. ALL DIMENSION IN MM [INCH]
 2. GENERAL TOLERANCE: X.X=±0.4
X.XX=±0.25
 3. TERM. NOS. FOR REF. ONLY
 4. CONTACT RATING SWITCHING: 150mA, 250V AC/DC
350mA, 110V AC/DC
 5. OPERATING FORCE: 425±100 CM/STANDARD
 6. OPERATING TEMP: -30° to 85°C
 7. CIRCUIT DP: 6 POSITIONS, 30° INDEX, NO STOPS.
 8. DIELECTRIC STRENGTH: 1000V RMS min.@Seo Level
 9. DESIGNATE MAJOR FEATURE
 10. HARDWARE SUPPLIED ON SWITCH— SEE BELOW
LOCKRING, LOCKWASHER, & HEX NUT

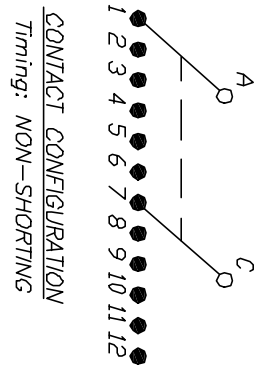

▲ HARDWARE SUPPLIED ON SWITCH

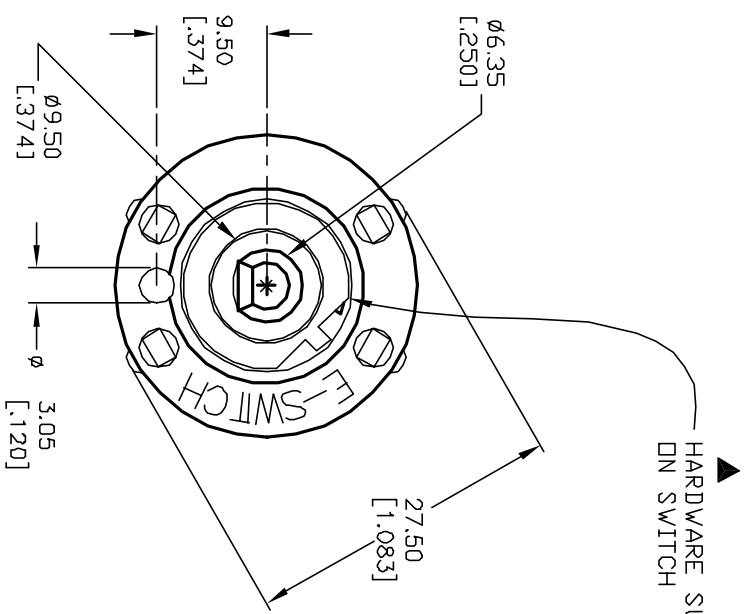

▲

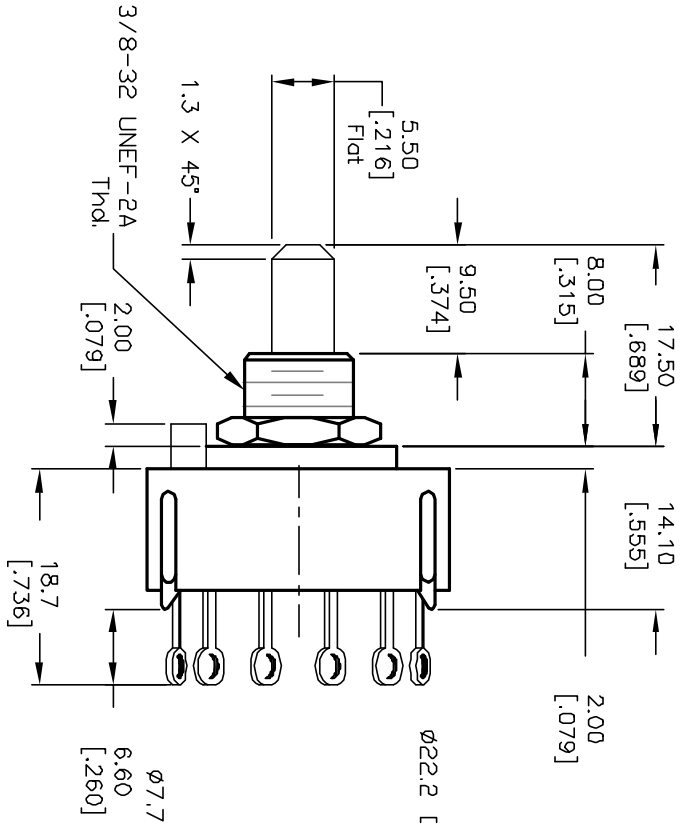

TERMINATION DETAIL
SCALE 2X

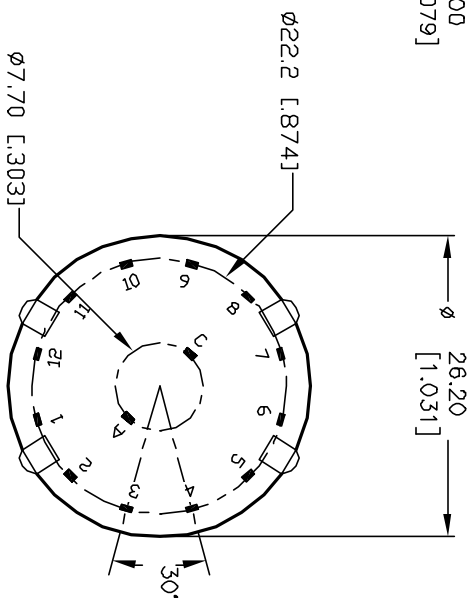
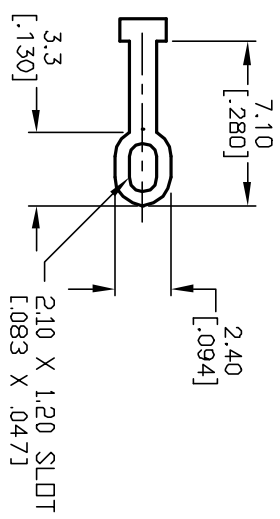

E-SWITCH®

KC2049.501NLS

REV.	ECN No.	DESCRIPTION	DATE	CHKD
A	12969	RELEASED FOR PRODUCTION	3/27/03	AR

TITLE	SCALE	DATE	DR	DWG	REV
KC2049.501NLS	1.5:1	3/27/03	AR	G510199	A

THE INFORMATION CONTAINED IN THIS DOCUMENT IS PROPRIETARY TO E-SWITCH AND IS NOT TO BE COPIED OR TRANSFERRED