

ISOMETRIC

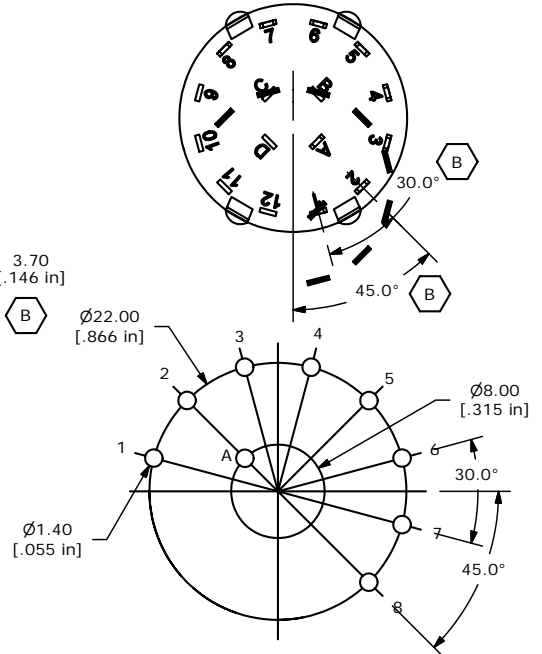
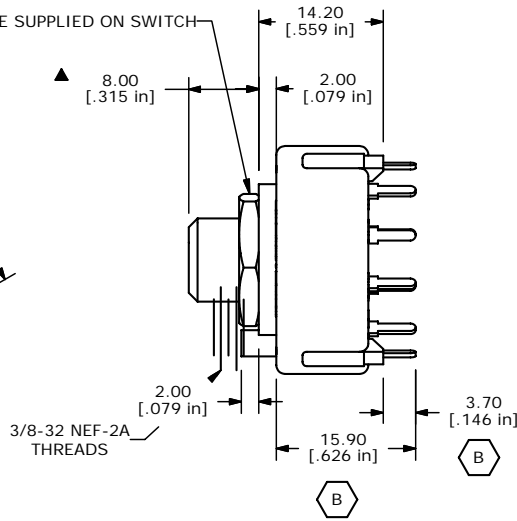
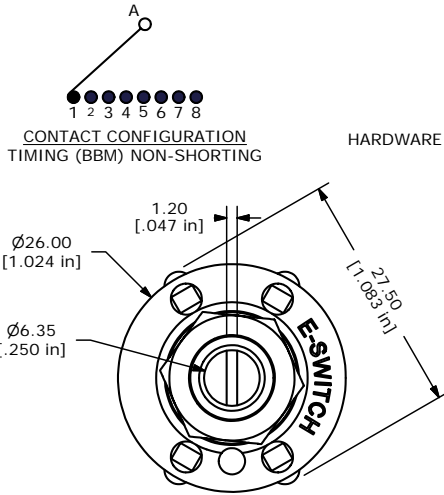

- NOTE:
1. ALL DIMENSIONS IN MM[INCH].
 2. GENERAL TOLERANCE: X.X=±0.4
X.XX=±0.25
 3. TERM. NOS. FOR REFERENCE ONLY.
 - ▲ 4. CONTACT MATERIAL: SILVER
 5. CONTACT RATING: 0.3A @ 125 VAC
 6. OPERATING FORCE: 500±200 GRAMS
 7. OPERATING TEMP: -30°C TO 85°C
 - ▲ 8. CIRCUIT DP: 8 POSITION 30° INDEX.
 9. DIELECTRIC STRENGTH: 500VAC-60 SEC
 - ▲ 10. HARDWARE SUPPLIED ON SWITCH:
LOCKWASHER, HEXNUT, STOP RING
 11. ▲ DENOTES CRITICAL PARAMETER.

D	15313	ADDED P.C.B LAYOUT	9/22/05	PH
C	15303	MADE CHANGES TO NOTES 5,6,8,9	9/20/05	PH
B	15021	CHANGED/ADDED DIMENSIONS	6/21/05	JB
A	14993	RELEASED FOR PRODUCTION	6/16/05	JB
REV	PCR NO	DESCRIPTION	DATE	BY

THE INFORMATION CONTAINED IN THIS DOCUMENT IS PROPRIETARY TO E-SWITCH AND IS NOT TO BE COPIED OR TRANSFERRED

E-SWITCH®

TITLE KC18D0.001NPS

SCALE	DATE	DR	DWG	REV
1.5:1	6/16/2005	JB	G510000	D